



XCubeSAN SANOS 4.0 Software Manual

Applicable Models:

XS5224D, XS5216D, XS5212D, XS5212S, XS5226D, XS5226S
XS3224D, XS3224S, XS3216D, XS3216S, XS3212D, XS3212S
XS3226D, XS3226S, XS1224D, XS1224S, XS1216D, XS1216S
XS1212D, XS1212S, XS1226D, XS1226S



QSAN Technology, Inc.
www.QSAN.com



Copyright

© Copyright 2020 QSAN Technology, Inc. All rights reserved. No part of this document may be reproduced or transmitted without written permission from QSAN Technology, Inc.

July 2020

This edition applies to QSAN XCubeSAN SANOS (SAN Operating System) 4.0. QSAN believes the information in this publication is accurate as of its publication date. The information is subject to change without notice.

Trademarks

QSAN, the QSAN logo, XCubeSAN, and QSAN.com are trademarks or registered trademarks of QSAN Technology, Inc.

Microsoft, Windows, Windows Server, and Hyper-V are trademarks or registered trademarks of Microsoft Corporation in the United States and/or other countries.

Linux is a trademark of Linus Torvalds in the United States and/or other countries.

UNIX is a registered trademark of The Open Group in the United States and other countries.

Mac and OS X are trademarks of Apple Inc., registered in the U.S. and other countries.

Java and all Java-based trademarks and logos are trademarks or registered trademarks of Oracle and/or its affiliates.

VMware, ESXi, and vSphere are registered trademarks or trademarks of VMware, Inc. in the United States and/or other countries.

Citrix and Xen are registered trademarks or trademarks of Citrix Systems, Inc. in the United States and/or other countries.

Other trademarks and trade names used in this document to refer to either the entities claiming the marks and names or their products are the property of their respective owners.

Table of Contents

Notices	xviii
Preface	xx
About This Manual	xx
Related Documents	xx
Technical Support	xx
Information, Tip and Caution	xxi
Conventions	xxi
1. SANOS Overview	1
1.1. Introduction to SANOS	1
1.1.1. SANOS System Architecture	1
1.1.2. SANOS Storage Pool Architecture	3
1.1.3. SANOS 4.0 Functionality List	4
1.2. Terminology	6
2. Prepare for Installation	9
2.1. Prepare for Configuration Planning	9
2.1.1. Configuration Planning for Initial Setup	16
2.1.2. Management IP Configuration Planning	16
2.1.3. Notification Configuration Planning	16
2.1.4. iSCSI Configuration Planning	17
2.1.5. Fibre Channel Configuration Planning	19
2.1.6. Storage Configuration Planning	20
2.1.7. Backup Configuration Planning	22
2.2. System Parameters	23
2.3. Configuration Example	26
3. Getting Started	33
3.1. Power on the Storage System	33
3.2. Discover the SAN Storage System	33
3.2.1. QFinder Utility	33
3.3. Initial Setup	35
4. SANOS User Interface	40
4.1. Accessing the Management Web UI	40
4.2. SANOS 4.0 Desktop Panel	41
4.3. Function Menus	42
4.3.1. Dashboard Menu	43

4.3.2.	System Settings Menu	44
4.3.3.	Host Configuration Menu	45
4.3.4.	Storage Management Menu	45
4.3.5.	Data Backup Menu	46
4.3.6.	Virtualization Menu	47
4.3.7.	Monitoring Menu	47
4.4.	Accessing the Management USB LCM	48
5.	Dashboard	52
5.1.	Dashboard	52
5.2.	Hardware Monitoring	60
6.	System Settings	63
6.1.	General System Settings	63
6.2.	Management Port Settings	65
6.3.	Power Settings	68
6.3.1.	Boot Management Settings	68
6.3.2.	Cache to Flash Status	70
6.3.3.	UPS Settings and Status	71
6.4.	Notification Settings	74
6.4.1.	Email Settings	74
6.4.2.	Alert Settings	76
6.4.3.	SNMP Settings	77
6.5.	Maintenance	79
6.5.1.	System Information	80
6.5.2.	Firmware Update	82
6.5.3.	Firmware Synchronization	86
6.5.4.	System Identification	87
6.5.5.	Reset to Factory Defaults	87
6.5.6.	Configuration Backup	89
6.5.7.	Reboot and Shutdown	90
6.6.	Disk Encryption	91
7.	Host Configuration	92
7.1.	Host Protocol Technology	92
7.1.1.	iSCSI Technology	92
7.1.2.	Fibre Channel Technology	93
7.2.	Host Connectivity Overview	94
7.3.	Configure iSCSI Connectivity	97
7.3.1.	Configure iSCSI Ports	97
7.3.2.	Configure iSCSI Settings	101
7.3.3.	Configure iSCSI Targets	102

7.3.4.	Configure iSCSI CHAP Accounts	106
7.3.5.	Active Sessions	109
7.4.	Configure Fibre Channel Connectivity	110
7.4.1.	Configure Fibre Channel Link Speed.....	111
7.4.2.	Configure Fibre Channel Topology	111
7.4.3.	Configure Fibre Channel Targets	112
7.4.4.	Clear Fibre Channel Counters.....	113
8.	Storage Management.....	114
8.1.	RAID Technology.....	114
8.1.1.	Traditional RAID Overview	114
8.1.2.	RAID EE Overview	120
8.1.3.	Theory of RAID EE Operation.....	121
8.2.	SANOS Storage Architecture	125
8.2.1.	Pool Technology.....	126
8.2.2.	Migrate vs. Add Disk Group.....	127
8.2.3.	Volume Technology	128
8.2.4.	LUN Technology	129
8.2.5.	Hot Spares	130
8.3.	Working with Disk Drives.....	131
8.3.1.	List Disks	133
8.3.2.	Operations on Disks	136
8.3.3.	S.M.A.R.T.	139
8.4.	Configure Thick Provisioning Pools	142
8.4.1.	Create a Thick Provisioning Pool.....	142
8.4.2.	List Thick Provisioning Pools	148
8.4.3.	Operations on Thick Provisioning Pools	150
8.4.4.	Migrate a Disk Group in a Thick Provisioning Pool.....	153
8.4.5.	Add a Disk Group in a Thick Provisioning Pool.....	156
8.5.	Configuring Volumes	159
8.5.1.	Create a Volume.....	160
8.5.2.	List Volumes.....	163
8.5.3.	Operations on Volumes	165
8.5.4.	Extend Volume Capacity.....	169
8.5.5.	Fast RAID Rebuild.....	170
8.6.	Configure LUN Mappings	172
8.6.1.	Map a LUN of iSCSI Connectivity.....	172
8.6.2.	Map a LUN of Fibre Channel Connectivity.....	173
8.6.3.	List LUN Mappings.....	174
8.6.4.	Operations on LUN Mappings	175
8.7.	Connect by Host Initiator.....	175

8.8.	Disk Roaming	176
9.	Thin Provisioning	177
9.1.	Overview	177
9.1.1.	Thick Provisioning vs. Thin Provisioning.....	178
9.2.	Theory of Operation	179
9.2.1.	Thin Provisioning Architecture.....	179
9.2.2.	Space Reclamation	180
9.2.3.	Thin Provisioning Policies	181
9.3.	Configure Thin Provisioning Pools	181
9.3.1.	Create a Thin Provisioning Pool.....	182
9.3.2.	List Thin Provisioning Pools.....	188
9.3.3.	Operations on Thin Provisioning Pools	190
9.3.4.	Add a Disk Group in a Thin Provisioning Pool.....	193
9.4.	Configure Volumes	196
9.4.1.	Create a Volume in a Thin Provisioning Pool.....	196
9.4.2.	List Volumes and Operations on Volumes.....	200
9.5.	Configure LUN Mappings and Connect by Host Initiator.....	201
10.	SSD Cache	202
10.1.	Overview	202
10.2.	Theory of Operation.....	204
10.2.1.	System Memory and SSD Cache Capacity.....	204
10.2.2.	SSD Cache Pool Architecture	205
10.2.3.	RAID Level of SSD Cache Pool	207
10.2.4.	Read/Write Cache Cases.....	209
10.2.5.	Populating the Cache.....	213
10.2.6.	SSD Cache Tuning.....	214
10.3.	Configure SSD Cache	216
10.3.1.	Enable SSD Cache License.....	216
10.3.2.	Create an SSD Cache Pool	217
10.3.3.	List SSD Cache Pools.....	220
10.3.4.	Operations on SSD Cache Pools.....	223
10.4.	Monitor SSD Cache Statistics	225
10.5.	SSD Cache Notices	228
11.	Auto Tiering	229
11.1.	Overview	229
11.1.1.	Tier Categories	230
11.1.2.	Flexible RAID and Disk Configurations	232
11.2.	Theory of Operation	232
11.2.1.	Auto Tiering Architecture.....	233

11.2.2.	Intelligent Auto Tiering Mechanism.....	235
11.2.3.	Tiering Policies	236
11.3.	Configure Auto Tiering Pools.....	238
11.3.1.	Enable Auto Tiering License.....	239
11.3.2.	Create an Auto Tiering Pool	239
11.3.3.	List Auto Tiering Pools.....	245
11.3.4.	Operations on Auto Tiering Pools.....	249
11.3.5.	Add a Tier (Disk Group) in an Auto Tiering Pool	251
11.3.6.	Hot Spares in an Auto Tiering Pool.....	254
11.4.	Configure Volumes	254
11.4.1.	Create a Volume in an Auto Tiering Pool	254
11.4.2.	List Volumes and Operations on Volumes.....	258
11.5.	Configure LUN Mappings and Connect by Host Initiator.....	259
11.6.	Transfer to Auto Tiering Pool.....	259
11.6.1.	Transfer from Thick Provisioning Pool to Auto Tiering.....	261
11.6.2.	Transfer from Thin Provisioning Pool to Auto Tiering.....	263
11.7.	SSD Cache vs. Auto Tiering.....	266
12.	Data Backup.....	268
12.1.	Managing Snapshots.....	268
12.1.1.	Theory of Operation	268
12.1.2.	Configure Snapshot	271
12.1.3.	Configure Rollback Snapshot.....	275
12.1.4.	Configure Schedule Snapshots.....	276
12.1.5.	Snapshot Notices.....	277
12.2.	Managing Local Clones	280
12.2.1.	Theory of Operation	280
12.2.2.	Configure Local Clone	283
12.2.3.	Configure Schedule Local Clone Tasks.....	286
12.2.4.	Local Cloning Options.....	287
12.2.5.	Local Clone Notices	288
12.3.	Managing Remote Replications.....	288
12.3.1.	Remote Replication Topologies	289
12.3.2.	Theory of Operation	292
12.3.3.	Configure Remote Replication	294
12.3.4.	Configure Traffic Shaping	300
12.3.5.	Configure Schedule Remote Replication Tasks.....	302
12.3.6.	Replication Options.....	303
12.3.7.	Configure MPIO in Remote Replication Task.....	304
12.3.8.	Configure MC/S in Remote Replication Task Path.....	310
12.3.9.	Local Clone Transfers to Remote Replication	313

13. Monitoring	319
13.1. Log Center	319
13.1.1. Operations on Event Logs	320
13.2. Monitoring Enclosures.....	321
13.2.1. Hardware Monitoring.....	321
13.2.2. Configuring SES.....	323
13.3. Performance Monitoring	325
13.3.1. Disk Performance Monitoring	325
13.3.2. Volume Performance Monitoring.....	326
13.3.3. iSCSI Port Performance Monitoring	328
13.3.4. Fibre Channel Port Monitoring	328
14. SED and ISE Support	329
14.1. Overview	329
14.2. Theory of Operation.....	331
14.2.1. SED Operation Process.....	331
14.2.2. ISE Technology.....	333
14.3. Configure Authentication Key	335
14.3.1. Operations on Authentication Key	335
14.4. Configure SEDs	340
14.4.1. List SEDs.....	341
14.4.2. Operations on SEDs	343
14.5. Configure SED Pools.....	347
14.5.1. Create an SED Pool	348
14.5.2. List SED Pools	353
14.5.3. Operations on SED Pools.....	356
14.5.4. Rebuild on SED Pools.....	356
14.5.5. Create an SSD Cache Pool on SED Pools.....	356
14.5.6. Data Backup on Encrypted Volumes	356
14.6. Configure ISE Drives	357
14.6.1. List ISE Drives.....	357
14.6.2. Operations on ISE Drives	360
15. QoS (Quality of Service)	362
15.1. Overview	362
15.1.1. QoS in Storage System	363
15.1.2. Benefit of QoS	363
15.1.3. QoS Use Cases	364
15.2. Theory of Operation.....	364
15.2.1. Priority and Target Response Time	365
15.2.2. Maximum IOPS and Maximum Throughput.....	366

15.3.	Configure QoS Settings	366
15.3.1.	Operations on QoS Settings	367
15.4.	Configure QoS Volumes	369
15.4.1.	List QoS Volumes.....	369
15.4.2.	Operations on QoS Volumes	371
16.	Troubleshooting.....	374
16.1.	Fault Isolation Methodology	374
16.1.1.	Basic Steps	374
16.1.2.	Stopping I/O.....	374
16.1.3.	Diagnostic Steps	374
16.2.	Rebuild	375
16.3.	Volume Restoration	377
16.3.1.	Configure Volume Restoration.....	378
17.	Support and Other Resources.....	379
17.1.	Getting Technical Support.....	379
17.2.	Online Customer Support	381
17.3.	Accessing Product Updates.....	385
17.4.	Documentation Feedback	386
Appendix.....	387
	Glossary and Acronym List.....	387
	End-User License Agreement (EULA)	390

Figures

Figure 1-1	SANOS System Architecture.....	1
Figure 1-2	SANOS System Architecture with Single Controller Configuration	2
Figure 1-3	SANOS Storage Pool Architecture	3
Figure 1-4	SANOS 4.0 Desktop Panel	4
Figure 2-1	Dual-controller Topology.....	18
Figure 3-1	QFinder Utility	34
Figure 3-2	Login Page of web UI	35
Figure 3-3	Initial Configuration Step 1	36
Figure 3-4	Initial Configuration Step 2	37
Figure 3-5	Initial Configuration Step 3	39
Figure 4-1	Login Page of web UI	40
Figure 4-2	SANOS 4.0 Desktop Panel	41
Figure 4-3	Portable USB LCM	48
Figure 4-4	USB LCM Screen.....	48
Figure 5-1	Dashboard Function Submenu.....	52
Figure 5-2	Dashboard.....	52
Figure 5-3	System Information Block in the Dashboard.....	53
Figure 5-4	System Information Popup Window	54
Figure 5-5	System View Block in the Dashboard	55
Figure 5-6	Pool Information Popup Window	56
Figure 5-7	Performance Block in the Dashboard	59
Figure 5-8	Event Logs in the Dashboard.....	59
Figure 5-9	Hardware Monitoring Function Submenu.....	60
Figure 5-10	Hardware Monitoring	61
Figure 5-11	Head Unit Popup Window	62
Figure 6-1	General Function Submenu	63
Figure 6-2	General Settings	64
Figure 6-3	Management Port Function Submenu.....	65
Figure 6-4	Management Port settings	66
Figure 6-5	Power Settings Function Submenu.....	68
Figure 6-6	Boot Management Settings.....	68
Figure 6-7	Cache to Flash	70
Figure 6-8	UPS Status and Settings	72
Figure 6-9	Notifications Function Submenu.....	74
Figure 6-10	Email Settings.....	75
Figure 6-11	Alert Settings	76
Figure 6-12	SNMP Settings.....	78

Figure 6-13	Maintenance Function Submenu	80
Figure 6-14	System Information.....	81
Figure 6-15	Firmware Update	83
Figure 6-16	Enable Licenses.....	84
Figure 6-17	Trial License.....	85
Figure 6-18	Both Firmware Versions are Synchronized	86
Figure 6-19	Turn on the UID (Unique Identifier) LED	87
Figure 6-20	Reset to Defaults	88
Figure 6-21	Configuration Backup.....	90
Figure 6-22	Reboot and Shutdown.....	91
Figure 6-23	Reboot Options.....	91
Figure 6-24	Disk Encryption Function Submenu	91
Figure 7-1	Overview Function Submenu	94
Figure 7-2	Host Port Overview.....	95
Figure 7-3	iSCSI Ports Function Submenu	97
Figure 7-4	List iSCSI Ports.....	97
Figure 7-5	iSCSI IP Address Settings.....	98
Figure 7-6	Set Link Aggregation	99
Figure 7-7	Set VLAN ID.....	100
Figure 7-8	Set Jumbo Frame	100
Figure 7-9	Ping Host.....	101
Figure 7-10	Entity Name and iSNS Settings	102
Figure 7-11	iSCSI Targets	103
Figure 7-12	Authentication Method	104
Figure 7-13	Change Target Name	105
Figure 7-14	Change Network Portal.....	105
Figure 7-15	Change Alias.....	106
Figure 7-16	Create a CHAP User	107
Figure 7-17	List CHAP Users	108
Figure 7-18	Modify a CHAP User.....	108
Figure 7-19	Active Sessions	109
Figure 7-20	Fibre Channel Ports Function Submenu	110
Figure 7-21	List Fibre Channel Ports.....	111
Figure 7-23	Change Topology.....	112
Figure 7-24	Target Configuration	113
Figure 8-1	Data Block Distributed of RAID 5EE	122
Figure 8-2	Disk 2 has Failed.....	123
Figure 8-3	Empty Blocks are Rebuilt from the Failed Disk Drive.....	123
Figure 8-4	Data is copied back	124
Figure 8-5	Data Block Distributed of RAID 60EE	124
Figure 8-6	Storage Architecture of Thick Provisioning Pool.....	126

Figure 8-7	Volume in Storage Architecture	128
Figure 8-8	LUM Mappings in Storage Architecture.....	130
Figure 8-9	Hot Spares	131
Figure 8-10	Disks Function Submenu	132
Figure 8-11	List Disks.....	134
Figure 8-12	Disk Health Check	136
Figure 8-13	Set Dedicated Spare.....	137
Figure 8-14	Update Disk Firmware.....	138
Figure 8-15	More Information of Disk Drive	139
Figure 8-16	S.M.A.R.T. Attributes of Disk Drive.....	140
Figure 8-17	S.M.A.R.T. Attributes of SSD	141
Figure 8-18	Disk Settings.....	142
Figure 8-19	Pools Function Submenu.....	142
Figure 8-20	Create a Thick Provision Pool Step 1	143
Figure 8-21	Create a Thick Provision Pool Step 2.....	144
Figure 8-22	Create a Thick Provision Pool Step 3.....	145
Figure 8-23	Create a Thick Provision Pool Step 4.....	146
Figure 8-24	Create a Thick Provision Pool Step 5.....	147
Figure 8-25	A Thick Provisioning Pool is Created.....	147
Figure 8-26	List Thick Provisioning Pools	148
Figure 8-27	Change Disk Properties.....	151
Figure 8-28	Transfer Thick Provisioning Pool to Auto Tiering	152
Figure 8-29	Migrate a Disk Group in a Thick Provisioning Pool.....	153
Figure 8-30	RAID Migration.....	154
Figure 8-31	Migrate RAID Level Step 1	155
Figure 8-32	Add a Disk Group in a Thick Provisioning Pool	157
Figure 8-33	Add a Disk Group to a Thick Provisioning Pool.....	158
Figure 8-34	A Disk Group is Added	159
Figure 8-35	Pools Function Submenu.....	159
Figure 8-36	Create a Volume in Thick Provisioning Pool Step 1	160
Figure 8-37	Create a Volume in Thick Provisioning Pool Step 2.....	161
Figure 8-38	Create a Volume in Thick Provisioning Pool Step 3.....	162
Figure 8-39	A Volume in Thick Provisioning Pool is Created and Initializing	163
Figure 8-40	List Volumes	163
Figure 8-41	Local Cloning Options	165
Figure 8-42	Map a LUN of iSCSI Connectivity	166
Figure 8-43	Unmap LUNs.....	166
Figure 8-44	Set Snapshot Space	167
Figure 8-45	Create Local Clone	167
Figure 8-46	Change Volume Properties.....	168
Figure 8-47	Verify Parity.....	169

Figure 8-48	Extend Volume Capacity	170
Figure 8-49	Enable Fast RAID Rebuild When Creating a Volume.....	171
Figure 8-50	Pools Function Submenu.....	172
Figure 8-51	Map a LUN of iSCSI Connectivity	173
Figure 8-52	Map a LUN of FC Connectivity.....	174
Figure 8-53	List LUN Mappings	174
Figure 9-1	Traditional Thick Provisioning	177
Figure 9-2	Thin Provisioning	178
Figure 9-3	Benefits of Thin Provisioning	178
Figure 9-4	Storage Architecture of Thin Provisioning Pool.....	179
Figure 9-5	Pools Function Submenu.....	182
Figure 9-6	Create a Thin Provisioning Pool Step 1	183
Figure 9-7	Create a Thin Provisioning Pool Step 2	184
Figure 9-8	Create a Thin Provisioning Pool Step 3	185
Figure 9-9	Create a Thin Provisioning Pool Step 4	186
Figure 9-10	Create a Thin Provisioning Pool Step 5	187
Figure 9-11	A Thin Provisioning Pool is Created.....	187
Figure 9-12	List Thin Provisioning Pools	188
Figure 9-13	Change Thin Provisioning Policy.....	191
Figure 9-14	Transfer Thin Provisioning Pool to Auto Tiering	192
Figure 9-15	Move Disk Group	193
Figure 9-16	Add a Disk Group in a Thin Provisioning Pool.....	194
Figure 9-17	Add a Disk Group to a Thin Provisioning Pool.....	195
Figure 9-18	A Disk Group is Added	196
Figure 9-19	Create a Volume in Thin Provisioning Pool Step 1	197
Figure 9-20	Create a Volume in Thin Provisioning Pool Step 2	198
Figure 9-21	Create a Volume in Thin Provisioning Pool Step 3	199
Figure 9-22	A Volume in Thin Provisioning Pool is Created.....	199
Figure 9-23	Change Volume Properties	201
Figure 10-1	SSD Read and Write Cache	203
Figure 10-2	Storage Architecture of SSD Cache Pool.....	205
Figure 10-3	The Relationship between SSD Cache Pool and Storage Pool	207
Figure 10-4	SSD Read Cache with NRAID+.....	208
Figure 10-5	SSD Read-write Cache with NRAID 1+	209
Figure 10-6	Read Data with Cache Miss	210
Figure 10-7	Read Data with Cache Hit	211
Figure 10-8	Write Data in SSD Read Cache	212
Figure 10-9	Write Data in SSD Read-write Cache	212
Figure 10-10	SSD Cache Function Submenu.....	216
Figure 10-11	Enable SSD Cache License	217
Figure 10-12	Create an SSD Cache Pool Step 1	217

Figure 10-13	Create an SSD Cache Pool Step 2	218
Figure 10-14	Create an SSD Cache Pool Step 3	219
Figure 10-15	An SSD Cache Pool is Created	219
Figure 10-16	Another SSD Cache Pool is Created	220
Figure 10-17	List SSD Cache Pools	221
Figure 10-18	Add / Remove SSDs from the SSD Cache Pool.....	224
Figure 10-19	Add SSDs into the SSD Cache Pool.....	225
Figure 10-20	SSD Cache Function Submenu.....	226
Figure 10-21	SSD Cache Statistics.....	227
Figure 11-1	Auto Tiering Pool.....	230
Figure 11-2	3 Levels of Tiered Storage	231
Figure 11-3	Flexible RAID and Disk Configurations	232
Figure 11-4	Storage Architecture of Auto Tiering Pool.....	233
Figure 11-5	Auto Tiering Relocation.....	236
Figure 11-6	Pools Function Submenu.....	239
Figure 11-7	Enable Auto Tiering License	239
Figure 11-8	Create an Auto Tiering Pool Step 1	240
Figure 11-9	Create an Auto Tiering Pool Step 2	241
Figure 11-10	Create an Auto Tiering Pool Step 3	242
Figure 11-11	Create an Auto Tiering Pool Step 4	243
Figure 11-12	Create an Auto Tiering Pool Wizard Step 5	244
Figure 11-13	An Auto Tiering Pool is Created	245
Figure 11-14	List Auto Tiering Pools.....	246
Figure 11-15	Auto Tiering Pools and Status.....	249
Figure 11-16	Relocation Schedule.....	250
Figure 11-17	Relocate Now.....	251
Figure 11-18	Add a Disk Group in an Auto Tiering Pool	252
Figure 11-19	Add Disk Group.....	253
Figure 11-20	Hot Spares in Auto Tiering Pool	254
Figure 11-21	Create a Volume of Auto Tiering Pool Step 1.....	255
Figure 11-22	Create a Volume of Auto Tiering Pool Step 2.....	256
Figure 11-23	Create a Volume of Auto Tiering Pool Step 3.....	257
Figure 11-24	A Volume in Auto Tiering Pool is Created	258
Figure 11-25	Change Volume Properties.....	259
Figure 11-26	Block Map of Thick Provisioning Pool Transferring to Auto Tiering	260
Figure 11-27	Block Map of Thin Provisioning Pool Transferring to Auto Tiering	260
Figure 11-28	Transfer Thick Provisioning Pool to Auto Tiering Step 1	261
Figure 11-29	Transfer Thick Provisioning Pool to Auto Tiering Step 2	262
Figure 11-30	Transfer Thick Provisioning Pool to Auto Tiering Step 3	263
Figure 11-31	Transfer Thin Provisioning Pool to Auto Tiering Step 1	264
Figure 11-32	Transfer Thin Provisioning Pool to Auto Tiering Step 2	265

Figure 11-33	Transfer Thin Provisioning Pool to Auto Tiering Step 3	266
Figure 11-34	SSD Cache vs. Auto Tiering	267
Figure 12-1	Copy-on-Write Technology.....	269
Figure 12-2	Volume Shadow Copy Services Workflow.....	270
Figure 12-3	Snapshot Function Submenu	271
Figure 12-4	Set Snapshot Space	271
Figure 12-5	Take Snapshot.....	272
Figure 12-6	List Snapshots.....	272
Figure 12-7	List Snapshots.....	273
Figure 12-8	Set Writable Snapshot Capacity to Expose Snapshot	274
Figure 12-9	Schedule Snapshots.....	276
Figure 12-10	Host data I/O Route.....	278
Figure 12-11	Local Clone Diagram	280
Figure 12-12	Local Clone Steps.....	281
Figure 12-13	Rollback Local Clone.....	283
Figure 12-14	Create Target Volume	284
Figure 12-15	List Source and Target Volumes for Local Clone	284
Figure 12-16	Create Local Clone	285
Figure 12-17	List Source and Target Volumes	285
Figure 12-18	Schedule Local Clone.....	286
Figure 12-19	Local Cloning Options	287
Figure 12-20	Remote Replication Diagram.....	289
Figure 12-21	Local Clone Transfers to Remote Replication.....	289
Figure 12-22	One-Directional Remote Replication	290
Figure 12-23	Bi-Directional Remote Replication.....	290
Figure 12-24	One-to-Many Remote Replication.....	291
Figure 12-25	Many-to One Remote Replication.....	291
Figure 12-26	Many-to Many Remote Replication	292
Figure 12-27	Remote Replication Steps.....	293
Figure 12-28	Snapshot Function Submenu	293
Figure 12-29	Example of Creating a Remote Replication Task.....	294
Figure 12-30	Create Target Volume in Site B	295
Figure 12-31	List Target Volume in Site B	295
Figure 12-32	Create a Remote Replication Task Step 1	296
Figure 12-33	Create a Remote Replication Task Step 2	297
Figure 12-34	Create a Remote Replication Task Step 3	298
Figure 12-35	Create a Remote Replication Task Step 4	299
Figure 12-36	Remote Replication Task is Created.....	299
Figure 12-37	Shaping Setting Configuration.....	301
Figure 12-38	Set Traffic Shaping.....	302
Figure 12-39	Schedule Remote Replication.....	303

Figure 12-40	Replication Options	303
Figure 12-41	Remote Replication MPIO Diagram.....	305
Figure 12-42	Remote Replication Source Controller Fail Diagram	305
Figure 12-43	Remote Replication Target Controller Fail Diagram	306
Figure 12-44	Add Multipath in Remote Replication Step 1.....	307
Figure 12-45	Add Multipath in Remote Replication Step 2.....	308
Figure 12-46	Add Multipath in Remote Replication Step 3.....	309
Figure 12-47	List Multipath in Remote Replication Task.....	309
Figure 12-48	Add Path Connection	311
Figure 12-49	List Multiple Connections in Remote Replication Task Path	311
Figure 12-50	Delete Path Connection	312
Figure 12-51	Local Clone Transfers to Remote Replication Diagram	313
Figure 12-52	List Source and Target Volumes for Local Clone	314
Figure 12-53	Rebuild Clone Relationship Step 1	315
Figure 12-54	Rebuild Clone Relationship Step 2	316
Figure 12-55	Rebuild Clone Relationship Step 3	317
Figure 12-56	Rebuild Clone Relationship Step 4	318
Figure 12-57	Remote Replication Task is Created.....	318
Figure 13-1	Log Center Function Submenu	319
Figure 13-2	Event Logs.....	319
Figure 13-3	Download Event Logs.....	320
Figure 13-4	Clear Event Logs.....	321
Figure 13-5	Enclosure Function Submenu.....	321
Figure 13-6	Hardware Monitoring	322
Figure 13-7	Enable SES	324
Figure 13-8	SES Status.....	324
Figure 13-9	Performance Function Submenu	325
Figure 13-10	Disk Performance Monitoring	326
Figure 13-11	Select Volumes to Monitor	327
Figure 13-12	Volume Performance Monitoring.....	327
Figure 13-13	iSCSI Performance Monitoring.....	328
Figure 14-1	SED Operation Process	332
Figure 14-2	ISE Technology	334
Figure 14-3	Disk Encryption Function Submenu	335
Figure 14-4	Authentication Key is Disabled.....	335
Figure 14-5	Enable Authentication Key.....	336
Figure 14-6	Authentication Key is Enabled.....	337
Figure 14-7	Export Authentication Key	338
Figure 14-8	Change Authentication Key	339
Figure 14-9	Disable Authentication Key.....	340
Figure 14-10	Disk Encryption Function Submenu	341

Figure 14-11	List SEDs	341
Figure 14-12	Initiate SEDs.....	343
Figure 14-13	Initiate SED Results	344
Figure 14-14	List SEDs	344
Figure 14-15	Unlock SEDs.....	345
Figure 14-16	Erase SEDs.....	346
Figure 14-17	Erase SED by PSID.....	347
Figure 14-18	Pools Function Submenu.....	347
Figure 14-19	Create an SED Pool Step 1	348
Figure 14-20	Create an SED Pool Step 2.....	349
Figure 14-21	Create an SED Pool Step 3.....	350
Figure 14-22	Create an SED Pool Step 4.....	351
Figure 14-23	Create an SED Pool Step 5.....	352
Figure 14-24	An SED Pool is Created	352
Figure 14-25	List SED Pools.....	353
Figure 14-26	Disks Function Submenu	357
Figure 14-27	List SEDs and ISE Drives	358
Figure 14-28	Instant Erase ISE drives	360
Figure 14-29	Instant Erase Results	360
Figure 15-1	Without and With QoS	365
Figure 15-2	QoS Settings Function Tab	367
Figure 15-3	QoS Setting is Disabled.....	367
Figure 15-4	QoS Setting with Priority and Target Response	368
Figure 15-5	QoS Setting with Maximum IOPS and Maximum Throughput.....	368
Figure 15-6	QoS Volumes Function Tab	369
Figure 15-7	List QoS Volumes with Priority and Target Response	369
Figure 15-8	List QoS Volumes with Maximum IOPS and Maximum Throughput.....	370
Figure 15-9	Set Priority.....	372
Figure 15-10	Priority and Target Response Time are Set.....	372
Figure 15-11	Set Maximum IOPS and Maximum Throughput.....	373
Figure 15-12	Maximum IOPS and Maximum Throughput are set	373
Figure 16-1	Volume Restoration.....	377
Figure 17-1	Download Service Package in the SANOS UI	380
Figure 17-2	Appearance of a Console Cable.....	381
Figure 17-3	Connect the Console Cable	381
Figure 17-4	The Procedures of Setup Serial Console by HyperTerminal	383
Figure 17-5	The Procedures of Setup Serial Console by PuTTY.....	385

Tables

Table 2-1	Configuration Worksheet	9
Table 2-2	System Parameters.....	23
Table 2-3	Configuration Worksheet Example	26
Table 4-1	SANOS 4.0 Function Menus	42
Table 4-2	USB LCM Function List	49
Table 4-3	USB LCM Menu Hierarchy.....	50
Table 5-1	System Information Block Descriptions	53
Table 5-2	Storage View Block Descriptions	55
Table 5-3	Volume Column Descriptions	56
Table 5-4	Disk Group Column Descriptions	57
Table 5-5	Disk Column Descriptions.....	57
Table 6-1	Power Module Column Descriptions	70
Table 6-2	Flash Module Column Descriptions	71
Table 6-3	UPS Column Descriptions.....	72
Table 6-4	Status in System Information Column Descriptions.....	81
Table 7-1	iSCSI Parameters.....	93
Table 7-2	Fibre Channel Parameters	94
Table 7-3	Active Sessions Column Descriptions	109
Table 8-1	RAID Level Summary - 1	118
Table 8-2	RAID Level Summary - 2.....	119
Table 8-3	RAID EE Level Summary.....	125
Table 8-4	Thick Provisioning Pool Parameters.....	127
Table 8-5	Volumes Parameters.....	128
Table 8-6	LUN Parameters	130
Table 8-7	Enclosure and Disk Parameters	133
Table 8-8	Disk Column Descriptions.....	134
Table 8-9	Pool Column Descriptions	148
Table 8-10	Disk Group Column Descriptions	149
Table 8-11	Disk Column Descriptions.....	150
Table 8-12	Volume Column Descriptions	164
Table 8-13	LUN Mapping Column Descriptions.....	175
Table 9-1	Thin Provisioning Pool Parameters.....	180
Table 9-2	Thin Provisioning Policies and Available Values	181
Table 9-3	Pool Column Descriptions	188
Table 9-4	Disk Group Column Descriptions	189
Table 9-5	Disk Column Descriptions.....	190
Table 9-6	Thin Provisioning Policy Column Descriptions	191

Table 10-1	The Relationship between System Memory and SSD Cache Capacity	205
Table 10-2	SSD Cache Parameters	206
Table 10-3	I/O Type Table for SSD Read Cache	215
Table 10-4	I/O Type Table for SSD Read-write Cache	216
Table 10-5	SSD Cache Pool Column Descriptions.....	221
Table 10-6	SSDs Column Descriptions	222
Table 10-7	Enabled Volume Column Descriptions	222
Table 10-8	SSD Cache Statistics Descriptions.....	228
Table 11-1	Auto Tiering Pool Parameters	234
Table 11-2	Summary of Tiering Policies.....	238
Table 11-3	Pool Column Descriptions	246
Table 11-4	Disk Group Column Descriptions	247
Table 11-5	Disk Column Descriptions.....	248
Table 11-6	Pool Tiering Status Column Descriptions.....	249
Table 11-7	SSD Cache vs. Auto Tiering	267
Table 12-1	Snapshot Parameters	271
Table 12-2	Snapshot Column Descriptions.....	273
Table 12-3	Local Clone Parameters.....	282
Table 12-4	Remote Replication Parameters	294
Table 14-1	Disk Column Descriptions.....	341
Table 14-2	Pool Column Descriptions	353
Table 14-3	Disk Group Column Descriptions	354
Table 14-4	Disk Column Descriptions.....	355
Table 14-5	Disk Column Descriptions.....	358
Table 15-1	QoS Volume Descriptions	370
Table 15-2	QoS Volume Descriptions with Priority and Target Response Time	370
Table 15-3	QoS Volume Descriptions with Maximum IOPS and Maximum Throughput.....	371
Table 16-1	RAID Rebuild	376
Table 16-2	Volume Restoration Column Descriptions	377

Notices

This XCubeSAN SANOS 4.0 user's manual is applicable to the following XCubeSAN models:

XCubeSAN Storage System 4U 19" Rack Mount Models

Model Name	Controller Type	Form Factor, Bay Count, and Rack Unit
XS5224D	Dual Controller	LFF 24-disk 4U Chassis
XS3224D	Dual Controller	LFF 24-disk 4U Chassis
XS3224S	Single Controller	LFF 24-disk 4U Chassis
XS1224D	Dual Controller	LFF 24-disk 4U Chassis
XS1224S	Single Controller	LFF 24-disk 4U Chassis

XCubeSAN Storage System 3U 19" Rack Mount Models

Model Name	Controller Type	Form Factor, Bay Count, and Rack Unit
XS5216D	Dual Controller	LFF 16-disk 3U Chassis
XS3216D	Dual Controller	LFF 16-disk 3U Chassis
XS3216S	Single Controller	LFF 16-disk 3U Chassis
XS1216D	Dual Controller	LFF 16-disk 3U Chassis
XS1216S	Single Controller	LFF 16-disk 3U Chassis

XCubeSAN Storage System 2U 19" Rack Mount Models

Model Name	Controller Type	Form Factor, Bay Count, and Rack Unit
XS5212D	Dual Controller	LFF 12-disk 2U Chassis
XS5212S	Single Controller	LFF 12-disk 2U Chassis
XS3212D	Dual Controller	LFF 12-disk 2U Chassis
XS3212S	Single Controller	LFF 12-disk 2U Chassis
XS1212D	Dual Controller	LFF 12-disk 2U Chassis
XS1212S	Single Controller	LFF 12-disk 2U Chassis
XS5226D	Dual Controller	SFF 26-disk 2U Chassis
XS5226S	Single Controller	SFF 26-disk 2U Chassis
XS3226D	Dual Controller	SFF 26-disk 2U Chassis
XS3226S	Single Controller	SFF 26-disk 2U Chassis
XS1226D	Dual Controller	SFF 26-disk 2U Chassis

XS1226S	Single Controller	SFF 26-disk 2U Chassis
---------	-------------------	------------------------

Information contained in this manual has been reviewed for accuracy. But it could include typographical errors or technical inaccuracies. Changes are made to the document periodically. These changes will be incorporated in new editions of the publication. QSAN may make improvements or changes in the products. All features, functionality, and product specifications are subject to change without prior notice or obligation. All statements, information, and recommendations in this document do not constitute a warranty of any kind, express or implied.

Any performance data contained herein was determined in a controlled environment. Therefore, the results obtained in other operating environments may vary significantly. Some measurements may have been made on development-level systems and there is no guarantee that these measurements will be the same on generally available systems. Furthermore, some measurements may have been estimated through extrapolation. Actual results may vary. Users of this document should verify the applicable data for their specific environment.

This information contains examples of data and reports used in daily business operations. To illustrate them as completely as possible, the examples include the names of individuals, companies, brands, and products.

All of these names are fictitious and any similarity to the names and addresses used by an actual business enterprise is entirely coincidental.

Preface

About This Manual

This manual provides technical guidance for designing and implementing QSAN XCubeSAN series SAN system, and it is intended for use by system administrators, SAN designers, storage consultants, or anyone who has purchased these products and is familiar with servers and computer networks, network administration, storage system installation and configuration, storage area network management, and relevant protocols.

Related Documents

There are related documents which can be downloaded from the website.

- [XCubeSAN QIG \(Quick Installation Guide\)](#)
- [XCubeSAN Hardware Manual](#)
- [XCubeSAN Configuration Worksheet](#)
- [XCubeSAN SANOS 4.0 Software Manual](#)
- [Compatibility Matrix](#)
- [White Papers](#)
- [Application Notes](#)

Technical Support

Do you have any questions or need help trouble-shooting a problem? Please contact QSAN Support, we will reply to you as soon as possible.

- Via the Web: https://www.qsan.com/technical_support
- Via Telephone: +886-2-77206355
(Service hours: 09:30 - 18:00, Monday - Friday, UTC+8)
- Via Skype Chat, Skype ID: qsan.support
(Service hours: 09:30 - 02:00, Monday - Friday, UTC+8, Summer time: 09:30 - 01:00)
- Via Email: support@qsan.com

Information, Tip and Caution

This manual uses the following symbols to draw attention to important safety and operational information.



INFORMATION:

INFORMATION provides useful knowledge, definition, or terminology for reference.



TIP:

TIP provides helpful suggestions for performing tasks more effectively.



CAUTION:

CAUTION indicates that failure to take a specified action could result in damage to the system.

Conventions

The following table describes the typographic conventions used in this manual.

Conventions	Description
Bold	Indicates text on a window, other than the window title, including menus, menu options, buttons, fields, and labels. Example: Click the OK button.
<i><Italic></i>	Indicates a variable, which is a placeholder for actual text provided by the user or system. Example: copy <i><source-file></i> <i><target-file></i> .
[] square brackets	Indicates optional values. Example: [a b] indicates that you can choose a, b, or nothing.
{ } braces	Indicates required or expected values. Example: { a b } indicates that you must choose either a or b.
vertical bar	Indicates that you have a choice between two or more options or

	arguments.
/ Slash	Indicates all options or arguments.
underline	Indicates the default value. Example: [<u>a</u> b]

1. SANOS Overview

SANOS (SAN Operating System) is QSAN’s proprietary SAN operating system and allows you to manage, monitor, and analyze the configuration and performance of your XCubeSAN series SAN storage system. This chapter provides an overview of the SANOS functionality and includes a brief explanation of storage terminology for you to be more familiar with the storage technologies used by the XCubeSAN system.

1.1. Introduction to SANOS

SANOS is equipped with a refreshingly simple to use web-based GUI and easily is deployable into any infrastructure. Based on the Linux kernel, the 64-bit in-house developed SANOS delivers comprehensive storage functionality and is suitable for primary or secondary storage for SMB to entry-level enterprise businesses. The following sections will introduce the SANOS system and storage pool architecture with enterprise-grade storage features.

1.1.1. SANOS System Architecture

SANOS supports Dual Active (Active/Active) controller system architecture with high availability. Figure 1-1 shows the SANOS system architecture with dual controller.

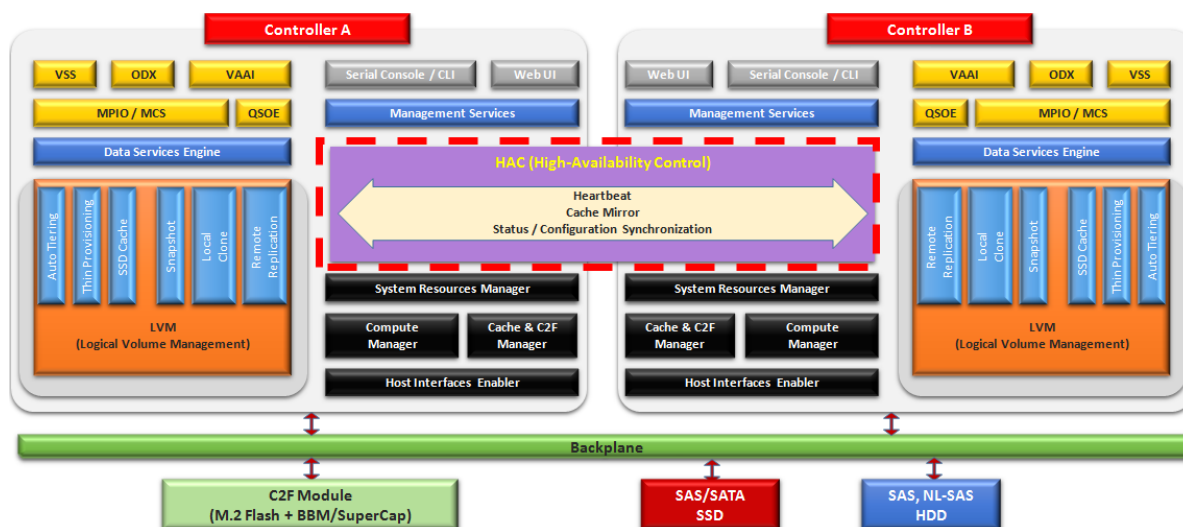

Figure 1-1 SANOS System Architecture

Figure 1-2 shows the SANOS system architecture with a single controller configuration. The data path is back and forth between the host interfaces and disk drives via the backplane. The LVM (Logical Volume Management) is the core to handle this data flow between them. It provides a method of allocating space on mass-storage devices that is more flexible than conventional partitioning schemes. In particular, a volume manager can concatenate, stripe together or otherwise combine partitions into larger virtual ones that administrators can re-size or move, potentially without interrupting system use. Of course, it may rely on the system resources manager to arrange the processor time slot and scheduled tasks.

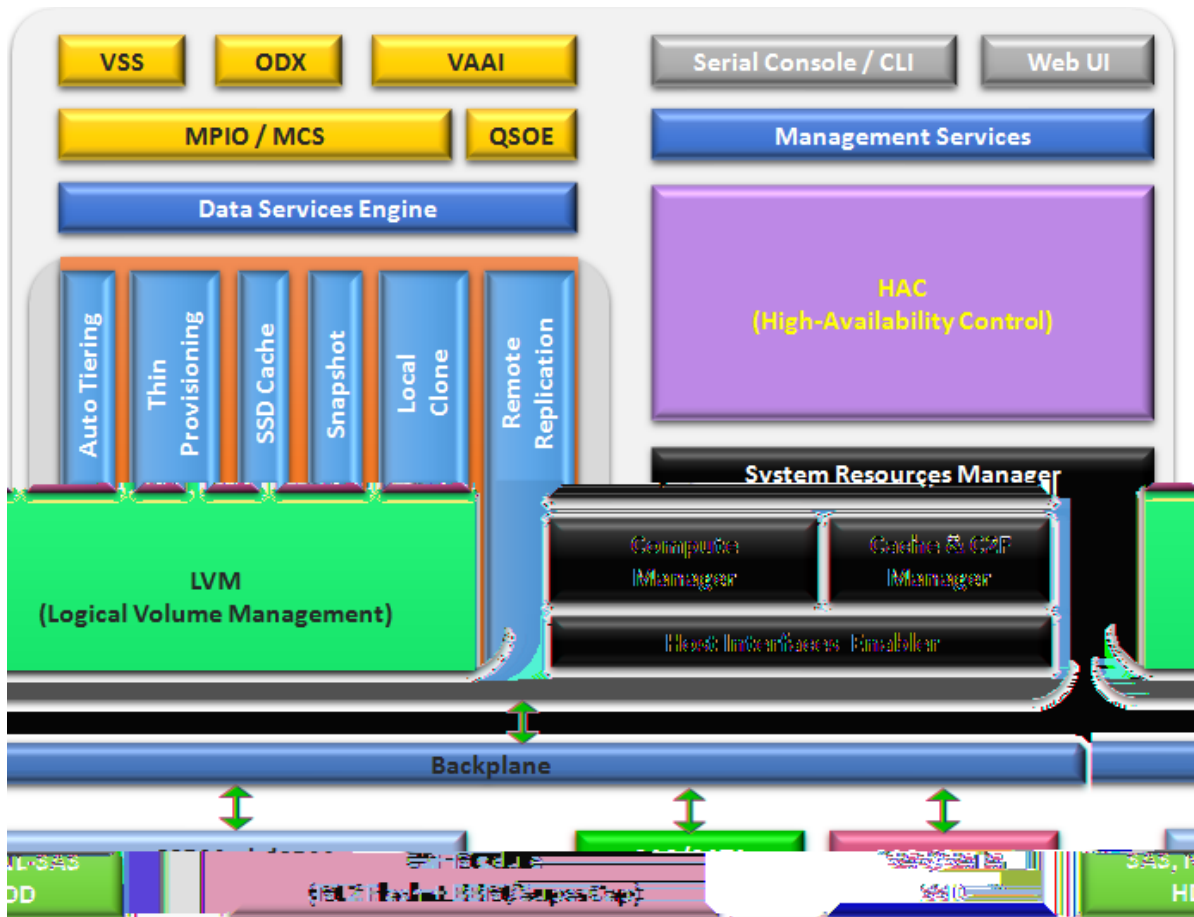

Figure 1-2 SANOS System Architecture with Single Controller Configuration

Based on LVM technology, it develops the features of auto tiering, thin provisioning, SSD cache and also data backup functions of snapshot, local clone, and remote replication. Upon LVM, QSOE (QSAN Storage Optimization Engine) which we are proud to develop, increases IOPS performance and overall system throughput. SANOS also supports several critical data services such as MPIO (Multi-Path I/O), MC/S (Multiple Connections per

Session), Microsoft VSS (Volume Shadow Copy Service), Microsoft ODX (Offloaded Data Transfer), and VMware VAAI (VMware vSphere Storage APIs for Array Integration). In the periphery, there are management service daemon to provide user interface operations, C2F (Cache to Flash) mechanism includes BBM (Battery Backup Module) / SCM (SuperCap Module) and M.2 flash module to protect cache data from power shortage. These key enterprise storage features are all together in a single box.

Under the operation of dual controllers, HAC (High Availability Control) module has a heartbeat mechanism to detect whether the other controller is alive. Cache mirror synchronizes the memory data of both controllers including the status and storage configuration. When one controller fails, the other controller can seamlessly take over all the tasks of the failed controller thanks to this cache sync. In addition, zero system downtime for the dual controller system takes place during firmware upgrading period.

1.1.2. SANOS Storage Pool Architecture

QSAN storage pool supports a variety of 3.5"/2.5" SAS/NL-SAS HDD and 2.5" SAS/SATA SSD flash drives. Figure 1-3 shows the storage pool architecture. Several disk drives are combined together to form a "disk group" with RAID protection. Then several disk groups can be combined to form a storage pool. A volume (virtual disk) is then created out of the storage pool and served to application servers over either iSCSI or Fibre Channel connections.

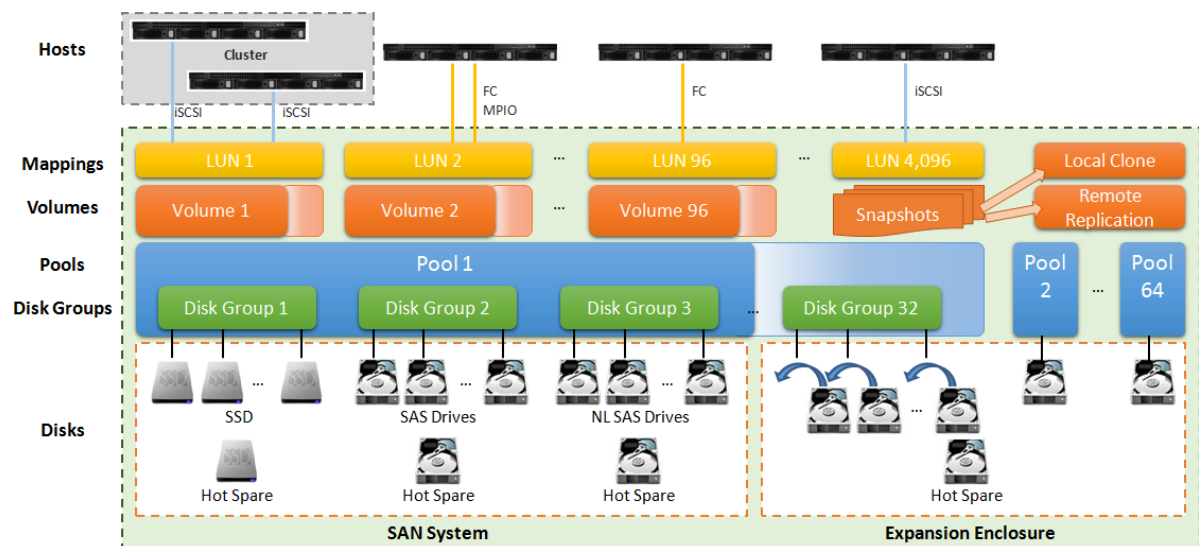

Figure 1-3 SANOS Storage Pool Architecture

If the local disk drives are not enough, QSAN expansion enclosures including disk drives can be added to increase storage capacity. There are host spares for standby if any disk drives in pools fail. Based on snapshot technology, the data backup features such as local clone and remote replications are also provided.

1.1.3. SANOS 4.0 Functionality List

SANOS 4.0 provides the following functionality for administrator management.

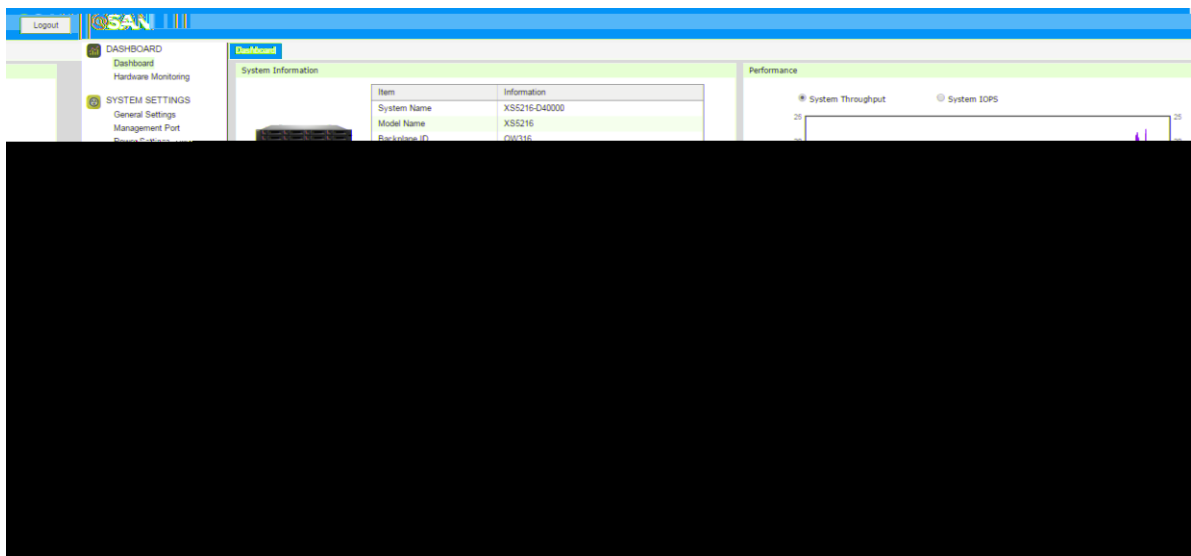

Figure 1-4 SANOS 4.0 Desktop Panel

System Management

- Change system name, date and time.
- Change admin's password, user's password, and configure login options.
- Configure management IP address, DNS, and service ports.
- Support boot management including auto shutdown, wake-on-LAN, and wake-on-SAS.
- Support network UPS via SNMP.
- Monitor cache to flash memory protection status. BBM (Battery Backup Module), SCM (Super Capacitor Module), and flash module are optional add-ons.
- Configure alert notifications through email, syslog server, or SNMP traps.
- Obtain system information and download service package.
- Update firmware of head unit or enclosure unit(s).

- Change operation mode of single or dual controller.
- Blink UID (Unique Identifier) LEDs for locating the storage arrays.
- System reset to default, configuration backup, and volume restoration for maintenance usage.
- System reboot or shutdown.

Host Connectivity

- Obtain host connectivity information.
- Configure iSCSI connectivity with IP address, link aggregation, VLAN (Virtual LAN) ID and jumbo frame.
- Setup entity name and iSNS (Internet Storage Name Service).
- Configure iSCSI target with CHAP (Challenge-Handshake Authentication Protocol) and mutual CHAP authentication.
- List and disconnect iSCSI sessions.
- Configure fibre channel connectivity with link speed and topology.

Storage Management

- Support RAID pool with RAID level 0, 1, 3, 5, 6, 0+1, 10, 30, 50, 60, and N-way mirror.
- Support thick provisioning pool and online migrate RAID pool.
- Support thin provisioning pool with space reclamation.
- Support 3-tier auto tiering with scheduled relocation. (auto tiering function is optional)
- Support SSD read cache or read-write cache to improve performance. (SSD cache function is optional)
- Support online storage pool capacity expansion and volume capacity extension.
- Configure disk properties with disk write cache, disk read-ahead, command queuing, and disk standby.
- Configure volume properties with background I/O priority, volume write-back cache, and video editing mode for enhanced performance.
- Support access control for LUN mapping.
- Support global, local, and dedicated hot spares for pool.
- Support fast RAID rebuild.
- Support disk drive health check and S.M.A.R.T attributes.
- Support hard drive firmware batch update.
- Support pool parity check and media scan for disk scrubbing.
- Support pool activated and deactivated for disk roaming.

Data Backup

- Support writable snapshot with manual or schedule tasks.
- Support volume cloning for local replication.
- Support remote replication with traffic shaping for dynamic bandwidth controller.

Virtualization Integration

- Seamless integrated with popular hypervisor including VMware vSphere, Microsoft Hyper-V, and Citrix XenServer.

Monitoring

- View event logs with different levels of event and download event logs.
- Monitor enclosure status of head and enclosure units.
- Monitor storage array performance.

1.2. Terminology

In this section, we introduce the terms that are used for the storage system throughout this manual.

RAID

RAID is the abbreviation of Redundant Array of Independent Disks. There are different RAID levels with different degrees of data protection, data availability, and performance to the host environment.

Pools

A storage pool is a collection of disk drives. One pool consists of a set of volumes and owns one RAID level attribute.

Volumes

Each pool can be divided into several volumes. The volumes from one pool have the same RAID level, but may have different volume capacity.

Fast RAID Rebuild

When executing rebuild, the Fast RAID Rebuild feature skips any partition of the volume where no write changes have occurred, it will focus only on the parts that have changed.

LUN

A LUN (Logical Unit Number) is a unique identifier for designating an individual or collection of physical or virtual storage devices that execute I/O commands with a host computer, as defined by the SCSI (Small Computer System Interface) standard.

iSCSI

iSCSI (Internet SCSI) is a protocol which encapsulates SCSI (Small Computer System Interface) commands and data in TCP/IP packets for linking storage devices with servers over common IP infrastructures.

Fibre Channel

Fibre channel is an extremely fast system interface. It was initially developed for use primarily in the supercomputing field, but has become the standard connection type for storage area networks (SAN) in enterprise storage.

SAS

Serial-attached SCSI offers advantages over older parallel technologies. The cables are thinner, and the connectors are less bulky. Serial data transfer allows the use of longer cables than parallel data connections.

Thick Provisioning

Thick provisioning is allocated upon creation the physical disk drive space and is equal to the user capacity seen by the host server. It also called fat provisioning.

Thin Provisioning

Thin provisioning is allocated on-demand and can be less than the user capacity seen by the host server. It involves using virtualization technology to give the appearance of having more physical resources than are actually available.

Auto Tiering

Auto Tiering is the automated progression or demotion of data across different tiers (types) of storage devices and media. The movement of data takes place in an automated way with the help of software and is assigned to the related media according to performance and capacity requirements. It also includes the ability to define rules and policies that dictate if and when data can be moved between the tiers, and in many cases provides the ability to pin data to tiers permanently or for specific periods of time.

SSD Cache

Smart Response Technology (also known as SSD cache) allows an SSD to function as cache for a HDD volume. It is a secondary cache that improves performance by keeping frequently accessed data on SSDs where they are read/write far more quickly than from the HDD volume.

Snapshot

A volume snapshot is the state of a system at a particular point in time.

Local Clone

Local clone function has another physical data copy as the original volume.

Remote Replication

Remote replication function prevents primary site failure by replicating data to the remote sites.

2. Prepare for Installation

Preparation for installation is an important task, it will help you to plan your system configuration and install your system smoothly. This chapter provides a description of the configuration planning steps and a configuration worksheet example for reference.

2.1. Prepare for Configuration Planning

Before installing your SAN storage system, it is highly recommended you to do installation preparation using the worksheet. Sticking to the worksheet will help you to setup and initialize the storage system. Please refer to the Table 2-1 for the content of worksheet. You can download this worksheet here: [XCubeSAN Configuration Worksheet](#).

Table 2-1 Configuration Worksheet

1. Initial Configuration	
Item	Value
System Name: The maximum length of the system name is 32 characters. Valid characters are [A~Z a~z 0~9 -_].	
Admin Password: The maximum length of the password is 12 characters. Valid characters are [A~Z a~z 0~9 ~!@#\$%^&*_-+=` \(){}[]:;'"<>.,?/].	
NTP Server: FQDN (Fully Qualified Domain Name) or IP address of NTP (Network Time Protocol) server.	
Time Zone: Depending on your location.	
2. Management Port Setting	
Item	Value
Management Port IP Address on Controller 1: IP address, subnet mask, and gateway of the management port on controller 1.	IP: SM: GW:
DNS Server Address: IP address of DNS (Domain Name System) server.	

Management Port IP Address on Controller 2: (optional) IP address, subnet mask, and gateway of the management port on controller 2.		IP: SM: GW:	
3. Notification Setting			
Item		Value	
Email-from Address: Email-from address to send event notification.			
Email-to Addresses: Email-to addresses to receive event notification		Email-to Address 1: Email-to Address 2: Email-to Address 3:	
SMTP Server: Network name or IP address of SMTP (Simple Mail Transfer Protocol) server.			
Syslog Server: (optional) FQDN or IP address of syslog server.			
SNMP Trap Addresses: (optional) FQDNs or IP addresses of SNMP (Simple Network Management Protocol) trap.		SNMP Trap Address 1: SNMP Trap Address 2: SNMP Trap Address 3:	
4. iSCSI Port Configuration			
Item		Value	
Onboard iSCSI Port IP Addresses: IP address, subnet mask, and gateway of the iSCSI ports. • Onboard 2 x 10GBASE-T iSCSI (RJ45) ports		/	
Controller 1	Onboard LAN1		Onboard LAN2
IP Address			
Subnet Mask			
Gateway			
Controller 2	Onboard LAN1		Onboard LAN2
IP Address			
Subnet Mask			
Gateway			

Slot 1 iSCSI Port IP Addresses: (optional) IP address, subnet mask, and gateway of the iSCSI ports. <ul style="list-style-type: none"> • 2-port 25GbE iSCSI Host Card (SFP28) • 4-port 10GbE iSCSI Host Card (SFP+) • 2-port 1GBASE-T iSCSI Host Card (RJ45) • 4-port 1GBASE-T iSCSI Host Card (RJ45) 				/
Controller 1	Slot 1 LAN1	Slot 1 LAN2	Slot 1 LAN3	Slot 1 LAN4
IP Address				
Subnet Mask				
Gateway				
Controller 2	Slot 1 LAN1	Slot 1 LAN2	Slot 1 LAN3	Slot 1 LAN4
IP Address				
Subnet Mask				
Gateway				
Slot 2 iSCSI Port IP Addresses: (optional) IP address, subnet mask, and gateway of the iSCSI ports. <ul style="list-style-type: none"> • 2-port 25GbE iSCSI Host Card (SFP28) • 4-port 10GbE iSCSI Host Card (SFP+) • 2-port 10GBASE-T iSCSI Host Card (RJ45) • 4-port 1GBASE-T iSCSI Host Card (RJ45) 				/
Controller 1	Slot 2 LAN1	Slot 2 LAN2	Slot 2 LAN3	
IP Address				
Subnet Mask				
Gateway				

CHAP Username: (optional) CHAP (Challenge-Handshake Authentication Protocol) username. The maximum length of the username is 223 characters. Valid characters are [A~Z a~z 0~9 ~!@#%&* _-+= (){}[];:<>./].		
CHAP Password: (optional) CHAP password. The length of the password is between 12 to 16 characters. Valid characters are [A~Z a~z 0~9 ~!@#%&* _-+=` \(){}[];:"'<>./].		
Mutual CHAP Username: (optional) Mutual CHAP username. The maximum length of the username is 223 characters. Valid characters are [A~Z a~z 0~9 ~!@#%&* _-+= (){}[];:<>./].		
Mutual CHAP Password: (optional) Mutual CHAP password. The length of the password is between 12 to 16 characters. Valid characters are [A~Z a~z 0~9 ~!@#%&* _-+=` \(){}[];:"'<>./].		
5. Fibre Channel Port Configuration		
Item		Value
Slot 1 Fibre Channel: (optional) Link speed and topology of the fibre channel ports. Topology support: FC-AL, point-to-point (16Gb and 32Gb Fibre Channel only support Point-to-Point topology) <ul style="list-style-type: none"> • 2-port 32Gb Fibre Channel Host Card (SFP28) • 4-port 16Gb Fibre Channel Host Card (SFP+) • 2-port 16Gb Fibre Channel Host Card (SFP+) 		/
Controller 1	Slot 1 FC1	Slot 1 FC2
Link Speed		
Topology		
Controller 2	Slot 1 FC1	Slot 1 FC2
Link Speed		
Topology		
6. Pool Configuration		
Item		Value
Pool Type: Thick Provisioning, Thin Provisioning, or Auto Tiering (Thin Provisioning Enabled).		

Pool Name: The maximum length of the pool name is 16 characters. Valid characters are [A~Z a~z 0~9 -_<>].	
Disks: Disk type, disk quantity, and the capacity.	SSD: SAS: NL-SAS:
RAID Level: RAID level 0, 1, 3, 5, 6, 0+1, 10, 30, 50, 60, and N-way mirror RAID EE level 5EE, 6EE, 50EE, and 60EE	
Raw Capacity: Sum of disk capacity.	
Estimate Capacity: Estimate capacity according to the RAID level.	
7. Volume Configuration	
Item	Value
Volume Name: The maximum length of the volume name is 32 characters. Valid characters are [A~Z a~z 0~9 -_<>].	
Capacity: Required capacity of the volume.	
Volume Type: RAID Volume or Backup Volume	
8. LUN Mapping Configuration	
Item	Value
Protocol: iSCSI or FCP.	
Volume Name: Select one of created volumes.	
Allowed Hosts: iSCSI IQN or Fibre Channel WWNN for access control. Wildcard (*) for access by all hosts.	
Target: iSCSI Target or Fibre Channel Target	
LUN: Support LUN (Logical Unit Number) from 0 to 255.	
Permission: Read-only or Read-write.	

9. SSD Cache Configuration	
Item	Value
SSD Cache Pool Name: The maximum length of the pool name is 16 characters. Valid characters are [A~Z a~z 0~9 -_<>].	
Cache Type: Read Cache (NRAID+) or Read-write Cache (RAID 1 or NRAID 1+).	
I/O Type: Database, File System, or Web Service.	
SSDs: SSD quantity and the capacity.	SSD:
Raw Capacity: Sum of disk capacity.	
10. Snapshot Configuration	
Item	Value
Volume Name: Select one of created volumes.	
Snapshot Space: Reserved snapshot space for the volume.	
Snapshot Name: The maximum length of the snapshot name is 32 characters. Valid characters are [A~Z a~z 0~9 -_<>].	
Schedule Snapshots: (optional) Define the cycle of snapshots.	
11. Local Clone Configuration	
Item	Value
Source Volume Name: Select one of created volume for source.	
Source Volume Capacity: Check the capacity of source volume.	
Target Volume Name: Select one of created volume for target.	
Target Volume Capacity: Check the capacity of target volume.	
Schedule Local Clones: (optional) Define the cycle of local clones.	

12. Remote Replication Configuration		
Item		Value
Source Volume Name: Select one of created volumes for source.		
Source Volume Capacity: Check the capacity of source volume.		
Source iSCSI Port: iSCSI port of source unit. It can be auto or dedicated iSCSI port.		
Target iSCSI Port IP Addresses: iSCSI port IP addresses of target unit.		
Target	Controller 1	Controller 2 (optional)
IP Address		
Target CHAP Username: (optional) CHAP username. The maximum length of the username is 223 characters. Valid characters are [A~Z a~z 0~9 ~!@#%&* _-+= (){}[];:<>./].		
Target CHAP Password: (optional) CHAP password. The length of the password is between 12 to 16 characters. Valid characters are [A~Z a~z 0~9 ~!@#%\$%^&* _-+=` \(){}[];:;'"<>.,./].		
Target Volume Name: Select one of created volume for target.		
Target Volume Capacity: Check the capacity of target volume.		
Schedule Remote Replications: (optional) Define the cycle of remote replications.		
Traffic Shaping for Peak Hour: (optional) Limit the transfer rate at peak hour.		
Traffic Shaping for Off-peak Hour: (optional) Limit the transfer rate at off-peak hour.		
Off-peak Hour: (optional) Define the off-peak hours.		

Now please follow the steps and fill the worksheet out for initial system configuration.

2.1.1. Configuration Planning for Initial Setup

In Table 2-1, the items on part 1, initial configuration, are listed for the initial setup. The information in the following checklist is helpful before the initial configuration is performed.

- System name allows maximum 32 characters. Valid characters are [A~Z | a~z | 0~9 | - _<>].
- Administrator password allows maximum 12 characters. Valid characters are [A~Z | a~z | 0~9 | ~!@#\$%^&* _-+=`|\(){}[];:”<>./].
- The date and time can be manually entered, but to keep the clock synchronized, recommend using a NTP (Network Time Protocol) service.
- Enter the time zone based on your geographical location.

2.1.2. Management IP Configuration Planning

With your network administrator, determine the IP addresses and network parameters you plan to use with the storage system, and record the information on part 2, management port setting in Table 2-1. You can manage the storage system through a dedicated management port at least on controller 1. This port must share a same subnet with the host you use to initialize the system. After initialization, any host on the same network and with a supported browser can manage the system through the management port.

- It is recommended using a static IP address for the management port. Please prepare a list of the static IP addresses, the subnet mask, and the default gateway.
- DNS (Domain Name Service) server address provides a means to translate FQDN (Fully Qualified Domain Name) to IP address. Some notification services need DNS setting.
- For dual controller configurations, the management port IP address on controller 2 is optional. If enabling the dual management ports setting, both management ports of controller 1 and 2 have their own IP addresses, and both are active. Otherwise, only the management port of master controller is active, the other one is standby. The management port

- SMTP server and email address to direct notification alerts the IT administrator and any alternate or back-up personnel.
- Syslog server address to log monitored events.
- SNMP (Simple Network Management Protocol) trap to send system event logs to SNMP trap agent.

2.1.4. iSCSI Configuration Planning

Although SAN is a private network environment, IP addresses of iSCSI data ports should be planned, too. Optionally, CHAP security information, including CHAP username and password should be prepared.

For an iSCSI dual-controller system, recommend to install an iSNS server on the same storage area network. For better usage of failover, the host must logon the target twice (both controller 1 and controller 2), and then the MPIO should setup automatically. More advanced, all the connections among hosts (with clustering), switches, and the dual-controller are recommended as redundant as shown below.

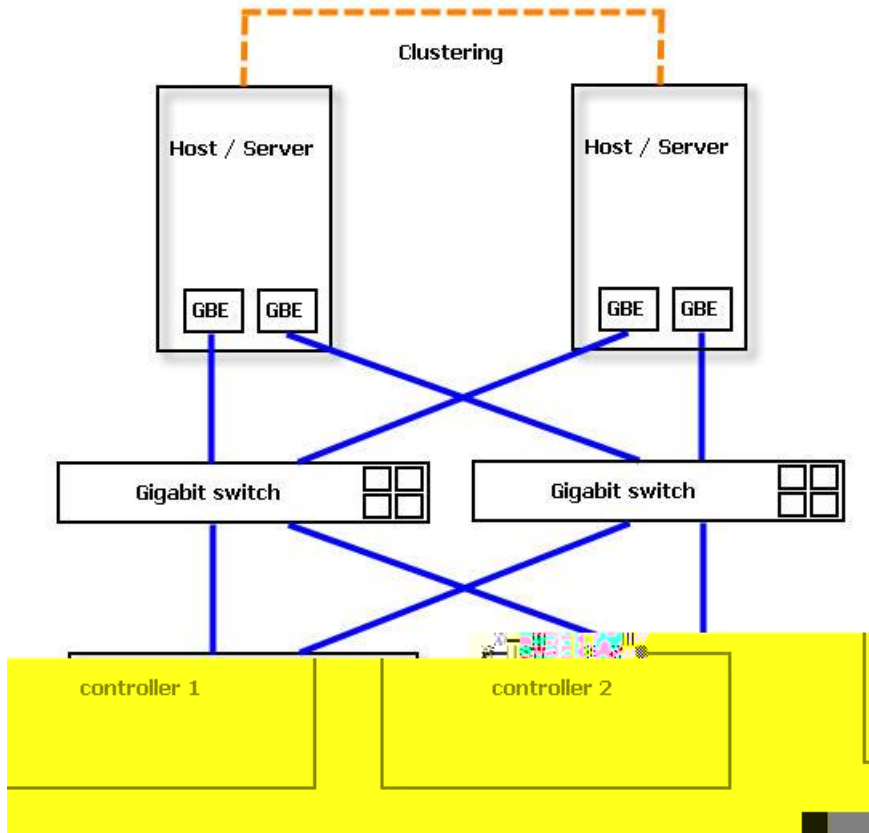

Figure 2-1 Dual-controller Topology

If you are using onboard iSCSI LAN ports, please fill in part 4, onboard iSCSI port IP addresses of iSCSI port configuration. Optionally, if you have iSCSI host card at slot 1 and slot 2, please fill in iSCSI port IP address.



INFORMATION:

iSCSI Host Cards at Slot 1 (PCIe Gen3 x 8)

- RHCE25P2, 2 x 25GbE iSCSI (SFP28) ports
- HQ-10G4S2, 4 x 10GbE iSCSI (SFP+) ports
- HQ-10G2T, 2 x 10GbE iSCSI (RJ45) ports
- HQ-01G4T, 4 x 1GbE iSCSI (RJ45) ports

iSCSI Host Cards at Slot 2 (PCIe Gen2 x 4)

- RHCE25P2, 2 x 25GbE iSCSI (SFP28) ports (Slot 2 provides 20Gb bandwidth)
- HQ-10G4S2, 4 x 10GbE iSCSI (SFP+) ports (Slot 2 provides 20Gb bandwidth)
- HQ-10G2T, 2 x 10GbE iSCSI (RJ45) ports
- HQ-01G4T, 4 x 1GbE iSCSI (RJ45) ports

- The entity name is for a device or gateway that is accessible from the network.
- An iSNS (Internet Storage Name Service) server uses the iSNS protocol to maintain information about active iSCSI devices on the network, including their IP addresses, iSCSI node names, and iSCSI targets. The iSNS protocol enables automated discovery and management of iSCSI devices on an IP storage network. An iSCSI initiator can query the iSNS server to discover iSCSI target devices.
- CHAP (Challenge-Handshake Authentication Protocol) is a one-way authentication which the initiator will be authenticated by the iSCSI target. CHAP requires that both the client and server know the plaintext of the password/secret, although it is never sent over the network. In addition, mutual CHAP is a two-way authentication between the iSCSI target and the initiator. For CHAP username, the maximum length of name is 223 characters and for CHAP password, the length range is from 12 to 16 alphanumeric characters.

2.1.5. Fibre Channel Configuration Planning

Optionally, if you have fibre channel host card, please fill at slot 1 fibre channel on part 5, fibre channel port configuration in Table 2-1. You have to be familiar the fibre channel protocol. Please consider the fibre channel typology, either direct-attach to HBA or connection with fibre channel switch.



INFORMATION:

Fibre Channel Host Card at Slot 1 (PCIe Gen3 x 8)

- RHCF32P2, 2 x 32Gb FC (SFP28) ports
- HQ-16F4S2, 4 x 16Gb FC (SFP+) ports
- HQ-16F2S2, 2 x 16Gb FC (SFP+) ports

Fibre Channel Host Cards at Slot 2 (PCIe Gen2 x 4)

- RHCF32P2, 2 x 32Gb FC (SFP28) ports (Slot 2 provides 20Gb bandwidth)
- HQ-16F4S2, 4 x 16Gb FC (SFP+) ports (Slot 2 provides 20Gb bandwidth)
- HQ-16F2S2, 2 x 16Gb FC (SFP+) ports (Slot 2 provides 20Gb bandwidth)

- Set the link speed as the same as the HBA or fibre channel switch, or set it to auto if you are not sure the link speed.
- Set the topology as the same as the HBA or fibre channel switch. Topology supports FC-AL, point-to-point (16Gb and 32Gb fibre channel only support Point-to-Point topology).

2.1.6. Storage Configuration Planning

This is the most important part to use the SAN storage system effectively. Depending on your application, estimated volume capacity, and disk failure risk, you should have a well-thought out storage plan. Complete all storage configuration planning jobs on part 6, pool configuration, part 7, volume configuration, part 8, LUN mapping configuration, and part 9, SSD cache configuration.

Planning the Disks

To plan the disk drives, determine:

- The cost/performance ratio of the disk drive type.
- Estimate the total required capacity of the system.
- Whether the disk drives are SSDs.
- Quantity of spare disks. Recommend for hot spare to active drive ratios, 1 in 30 for SAS drives and 1 in 15 for NL-SAS.

Planning the Pools

Necessary activities are in the following, please fill in part 6, pool configuration, in Table 2-1.

- The pool name, the maximum length of name is 16 characters.

- According to the pool and disk drive characteristics, such as total capacity, budget, performance, and reliability, determine a pool type (thick, thin provisioning, or auto tiering) and a RAID level of storage systems to use. For example, create a pool which is grouped by RAID 10 for performance and RAID 5 in another storage pool to achieve desired results.
- Plan to extend the capacity of the storage pool in the future.

Planning the Volumes

A volume is a member of the pool. Determine the following items and fill in part 7, volume configuration, in Table 2-1.

- The volume name, the maximum length of name is 32 characters.
- The volume capacity.
- Plan the volume capacity for local clone or remote replication. Set it as RAID volume for normal RAID volume usage, or set it as backup volume for the backup target of local clone or remote replication.

Planning the LUNs

LUN is a unique identifier which volume maps it to differentiate among separate devices. At the same time, there are some access controls by allowed hosts, target, LUN (logic unit number), and read/write permission. Please fill in part 8, LUN mapping configuration, in Table 2-1.

- Prepare an allowed host list for access control. They are (iSCSI Qualified Name) or Fibre Channel WWNN (World Wide Node Name). Set it as wildcard (*) for access by all hosts.
- Select an iSCSI target for iSCSI network portal. Or a FC target.
- Support LUN from 0 to 255.
- Usually, set the volume as read-write permission. For read only purpose, set it as read-only.

Planning the SSD Cache

Optionally, preparing for some SSDs will enhance the system performance. Please fill in part 9, SSD cache configuration, in Table 2-1.

- For SSD cache planning, the capacity of read cache is the sum of SSDs. But the capacity of read-write cache is half of all SSDs because it needs RAID protection for write buffer.

2.1.7. Backup Configuration Planning

Backup plan is also an important job for disaster recovery. Complete the backup configuration planning jobs on part 10, snapshot configuration, part 11, local clone configuration, and part 12, remote replication configuration.

Planning the Snapshots

To plan the snapshots, you have to reserve some snapshot spaces from the pool. Normally, we suggest reserving **20%** of the volume capacity as a minimum.

- Select a volume and reserve its snapshot space.
- Plan the schedule of snapshots, determine the cycle of taken snapshots. It can be hourly, daily, or weekly.

Planning the Local Clones

To plan the local clones, you have to select a source volume and prepare a target volume which the source clones to.

- Select a source volume and check its capacity.
- Prepare a target volume and set it as backup volume. The capacity of target volume should be larger than the source one.
- Plan the schedule local clones, determine the cycle of executing clone tasks. It can be hourly, daily, or weekly.

Planning the Remote Replications

To plan the remote replications, except to select a source volume in source unit and prepare a target volume which the source replicates to in target unit, you have to prepare the information of iSCSI port IP addresses to transfer the data. In addition, according to the network bandwidth, determine the transfer rate at peak and off-peak hours.

- Select a source volume and check its capacity in source unit.
- Select a source iSCSI port to send the replication data.
- Prepare the information of iSCSI port IP addresses in target unit to receive the replication data. Also prepare CHAP username and password if the target unit is enabled CHAP authentication.
- Prepare a target volume and set it as backup volume in target unit. The capacity of target volume should be larger than the source one.
- Plan the schedule remote replications, determine the cycle of executing replication tasks. It can be hourly, daily, or weekly.

- Define the off-peak hours and plan the transfer rate at peak and off-peak hours.

2.2. System Parameters

In this section, we list all of system parameters which will help you to understand and plan the system configuration. The following table shows the maximum number of each item you can use.

Table 2-2 System Parameters

iSCSI Parameters	
Item	Value
Maximum iSCSI target quantity per system	256
Maximum initiator address quantity per system	256
Maximum host quantity for single controller system	512
Maximum host quantity for dual controller system	1,024
Maximum iSCSI session quantity for single controller	1,024
Maximum iSCSI session quantity for dual controller	2,048
Maximum iSCSI connection quantity for single controller	4,096
Maximum iSCSI connection quantity for dual controller	8,192
Maximum CHAP accounts per system	64
Fibre Channel Parameters	
Item	Value
Maximum host quantity for single controller	256
Maximum host quantity for dual controller	512
Expansion Unit and Disk Parameters	
Item	Value
Maximum expansion unit quantity in a system	10
Maximum disk quantity in a system	286
Pool Parameters (Thick Provisioning / Thin Provisioning / Auto Tiering)	
Item	Value
Maximum disk group quantity in a pool	32
Maximum disk drive quantity in a disk group (include dedicated spares)	64
Maximum disk drive quantity in a pool (include dedicated spares)	256
Maximum pool quantity per system	64

Maximum addressable volume capacity of an auto tiering pool	256TB
LUN Parameters	
Item	Value
Maximum LUN quantity per system	4,096
SSD Cache Parameters	
Item	Value
Maximum SSD cache pool quantity per system (either dual controller or single controller)	4
Maximum SSD quantity in an SSD cache pool	8
Maximum addressable capacity of an SSD cache pool	32TB
Maximum quantity of volume shared in an SSD cache pool	32
Maximum dedicated spare SSD quantity in an SSD cache pool	4
Snapshot Parameters	
Item	Value
Maximum snapshot quantity per volume	64
Maximum volume quantity for snapshot	64
Maximum snapshot quantity per system	4,096 (= 64 x 64)
Local Clone Parameters	
Item	Value
Maximum clone task quantity per volume (Maximum clone pairs per source volume)	1
Maximum clone task quantity per system	64
Remote Replication Parameters	
Item	Value
Maximum remote replication task quantity per volume (Maximum remote replication pairs per source volume)	1
Maximum remote replication task quantity per system	32
Maximum traffic shaping quantity per system	8
Maximum iSCSI multi-path quantity in a remote replication task	2
Maximum iSCSI multiple connection quantity per remote replication task path	4

2.3. Configuration Example

The following is an example of finished configuration worksheet just for reference.

Table 2-3 Configuration Worksheet Example

1. Initial Configuration	
Item	Value
System Name: The maximum length of the system name is 32 characters. Valid characters are [A~Z a~z 0~9 -_].	XCubeSAN
Admin Password: The maximum length of the password is 12 characters. Valid characters are [A~Z a~z 0~9 ~!@#\$%^&*_- +=`\ (){}[];:"'<>.,?/].	1234
NTP Server: FQDN (Fully Qualified Domain Name) or IP address of NTP (Network Time Protocol) server.	pool.ntp.org
Time Zone: Depending on your location.	(GM +08:00) Taipei
2. Management Port Setting	
Item	Value
Management Port IP Address on Controller 1: IP address, subnet mask, and gateway of the management port on controller 1.	IP: 192.168.1.234 SM: 255.255.255.0 GW: 192.168.1.254
DNS Server Address: IP address of DNS (Domain Name System) server.	8.8.8.8
Management Port IP Address on Controller 2: (optional) IP address, subnet mask, and gateway of the management port on controller 2.	IP: 192.168.1.235 SM: 255.255.255.0 GW: 192.168.1.254
3. Notification Setting	
Item	Value
Email-from Address: Email-from address to send event notification.	admin@company.com

Email-to Addresses: Email-to addresses to receive event notification	Email-to Address 1: user1@company.com Email-to Address 2: user2@company.com Email-to Address 3: user3@company.com
SMTP Server: Network name or IP address of SMTP (Simple Mail Transfer Protocol) server.	smtp.company.com
Syslog Server: (optional) FQDN or IP address of syslog server.	syslog.company.com
SNMP Trap Addresses: (optional) FQDNs or IP addresses of SNMP (Simple Network Management Protocol) trap.	SNMP Trap Address 1: snmp1.company.com SNMP Trap Address 2: snmp2.company.com SNMP Trap Address 3: snmp3.company.com

4. iSCSI Port Configuration

Item	Value												
Onboard iSCSI Port IP Addresses: IP address, subnet mask, and gateway of the iSCSI ports. <ul style="list-style-type: none"> Onboard 2 x 10GBASE-T iSCSI (RJ45) ports 	/												
<table border="1" style="width: 100%; border-collapse: collapse;"> <thead> <tr> <th style="width: 25%;">Controller 1</th> <th style="width: 50%;">Onboard LAN1</th> <th style="width: 25%;">Onboard LAN2</th> </tr> </thead> <tbody> <tr> <td>IP Address</td> <td>10.10.1.1</td> <td>10.10.2.1</td> </tr> <tr> <td>Subnet Mask</td> <td>255.255.255.0</td> <td>255.255.255.0</td> </tr> <tr> <td>Gateway</td> <td>10.10.1.254</td> <td>10.10.2.254</td> </tr> </tbody> </table>	Controller 1	Onboard LAN1	Onboard LAN2	IP Address	10.10.1.1	10.10.2.1	Subnet Mask	255.255.255.0	255.255.255.0	Gateway	10.10.1.254	10.10.2.254	
Controller 1	Onboard LAN1	Onboard LAN2											
IP Address	10.10.1.1	10.10.2.1											
Subnet Mask	255.255.255.0	255.255.255.0											
Gateway	10.10.1.254	10.10.2.254											
<table border="1" style="width: 100%; border-collapse: collapse;"> <thead> <tr> <th style="width: 25%;">Controller 2</th> <th style="width: 50%;">Onboard LAN1</th> <th style="width: 25%;">Onboard LAN2</th> </tr> </thead> <tbody> <tr> <td>IP Address</td> <td>10.10.3.1</td> <td>10.10.4.1</td> </tr> <tr> <td>Subnet Mask</td> <td>255.255.255.0</td> <td>255.255.255.0</td> </tr> <tr> <td>Gateway</td> <td>10.10.3.254</td> <td>10.10.4.254</td> </tr> </tbody> </table>	Controller 2	Onboard LAN1	Onboard LAN2	IP Address	10.10.3.1	10.10.4.1	Subnet Mask	255.255.255.0	255.255.255.0	Gateway	10.10.3.254	10.10.4.254	
Controller 2	Onboard LAN1	Onboard LAN2											
IP Address	10.10.3.1	10.10.4.1											
Subnet Mask	255.255.255.0	255.255.255.0											
Gateway	10.10.3.254	10.10.4.254											
Slot 1 iSCSI Port IP Addresses: (optional) IP address, subnet mask, and gateway of the iSCSI ports. <ul style="list-style-type: none"> 2-port 25GbE iSCSI Host Card (SFP28) 4-port 10GbE iSCSI Host Card (SFP+) 2-port 1GBASE-T iSCSI Host Card (RJ45) 4-port 1GBASE-T iSCSI Host Card (RJ45) 	/												

Controller 1	Slot 1 LAN1	Slot 1 LAN2	Slot 1 LAN3	Slot 1 LAN4		
IP Address	10.10.11.1					
Subnet Mask	255.255.255.0					
Gateway	10.10.11.254					
Controller 2	Slot 1 LAN1	Slot 1 LAN2	Slot 1 LAN3	Slot 1 LAN4		
IP Address	10.10.21.1					
Subnet Mask	255.255.255.0					
Gateway	10.10.21.254					
Slot 2 iSCSI Port IP Addresses: (optional) IP address, subnet mask, and gateway of the iSCSI ports.						
<ul style="list-style-type: none"> • 2-port 25GbE iSCSI Host Card (SFP28) • 4-port 10GbE iSCSI Host Card (SFP+) • 2-port 1GBASE-T iSCSI Host Card (RJ45) • 4-port 1GBASE-T iSCSI Host Card (RJ45) 						
Controller 1	Slot 2 LAN1	Slot 2 LAN2			Slot 2 LAN3	Slot 2 LAN4
IP Address	10.10.31.1					
Subnet Mask	255.255.255.0					
Gateway	10.10.31.254					
Controller 2	Slot 2 LAN1	Slot 2 LAN2	Slot 2 LAN3	Slot 2 LAN4		
IP Address	10.10.41.1					
Subnet Mask	255.255.255.0					
Gateway	10.10.41.254					
Entity Name: The entity name is for a device or gateway that is accessible from the network. The maximum length of the entity name is 200 characters. Valid characters are [a~z 0~9 -.:].			lqn.2004-08.com.qsan			
iSNS IP Address: (optional) IP address of iSNS (Internet Storage Name Server) server.			10.1.1.1			
CHAP Username: (optional) CHAP (Challenge-Handshake Authentication Protocol) username. The maximum length of the username is 223 characters. Valid characters are [A~Z a~z 0~9 ~!@#%&* _-+= (){}[];:<>./].			chap1			

CHAP Password: (optional) CHAP password. The length of the password is between 12 to 16 characters. Valid characters are [A~Z a~z 0~9 ~!@#%&*_+=`\'()\{\}[];'"<>.,?/].	123456789012			
Mutual CHAP Username: (optional) CHAP (Challenge-Handshake Authentication Protocol) username. The maximum length of the username is 223 characters. Valid characters are [A~Z a~z 0~9 ~!@#%&*_+= ()\{\}[];:<>.,?/].	mutualchap1			
Mutual CHAP Password: (optional) CHAP password. The length of the password is between 12 to 16 characters. Valid characters are [A~Z a~z 0~9 ~!@#%&*_+=`\'()\{\}[];'"<>.,?/].	123456789012			
5. Fibre Channel Port Configuration				
Item	Value			
Slot 1 Fibre Channel: (optional) Link speed and topology of the fibre channel ports. Topology support: FC-AL, point-to-point (16Gb and 32Gb Fibre Channel only support Point-to-Point topology) <ul style="list-style-type: none"> 2-port 32Gb Fibre Channel Host Card (SFP28) 4-port 16Gb Fibre Channel Host Card (SFP+) 2-port 16Gb Fibre Channel Host Card (SFP+) 	/			
Controller 1	Slot 1 FC1	Slot 1 FC2	Slot 1 FC3	Slot 1 FC4
Link Speed	Auto			
Topology	Point-to-Point			
Controller 2	Slot 1 FC1	Slot 1 FC2	Slot 1 FC3	Slot 1 FC4
Link Speed	Auto			
Topology	Point-to-Point			
6. Pool Configuration				
Item		Value		
Pool Type: Thick Provisioning, Thin Provisioning, or Auto Tiering (Thin Provisioning Enabled).		Auto Tiering		
Pool Name: The maximum length of the pool name is 16 characters. Valid characters are [A~Z a~z 0~9 -_<>].		PL1		

Disks: Disk type, disk quantity, and the capacity.	SSD: 4x 100GB SAS: 4x 600GB NL-SAS: 4x 4TB
RAID Level: RAID level 0, 1, 3, 5, 6, 0+1, 10, 30, 50, 60, and N-way mirror RAID EE level 5EE, 6EE, 50EE, and 60EE	RAID 5
Raw Capacity: Sum of disk capacity.	18.8TB (= 100GB x 4 + 600GB x 4 + 4TB x 4)
Estimate Capacity: Estimate capacity according to the RAID level.	14.1TB (= 100GB x 3 + 600GB x 3 + 4TB x 3)
7. Volume Configuration	
Item	Value
Volume Name: The maximum length of the volume name is 32 characters. Valid characters are [A~Z a~z 0~9 -_<>].	V1-PL1
Capacity: Required capacity of the volume.	8TB
Volume Type: RAID Volume or Backup Volume	RAID Volume
8. LUN Mapping Configuration	
Item	Value
Protocol: iSCSI or FCP.	iSCSI
Volume Name: Select one of created volumes.	V1-PL1
Allowed Hosts: iSCSI IQN or Fibre Channel WWNN for access control. Wildcard (*) for access by all hosts.	*
Target: iSCSI Target or Fibre Channel Target	0
LUN: Support LUN (Logical Unit Number) from 0 to 255.	LUN 0
Permission: Read-only or Read-write.	Read-write

9. SSD Cache Configuration	
Item	Value
SSD Cache Pool Name: The maximum length of the pool name is 16 characters. Valid characters are [A~Z a~z 0~9 -_<>].	SCPL1
Cache Type: Read Cache (NRAID+) or Read-write Cache (RAID 1 or NRAID 1+).	Read Cache
I/O Type: Database, File System, or Web Service.	Database
SSDs: SSD quantity and the capacity.	SSD: 2x 400GB
Raw Capacity: Sum of disk capacity.	800GB
10. Snapshot Configuration	
Item	Value
Volume Name: Select one of created volumes.	V1-PL1
Snapshot Space: Reserved snapshot space for the volume.	1.6TB
Snapshot Name: The maximum length of the snapshot name is 32 characters. Valid characters are [A~Z a~z 0~9 -_<>].	Snap-V1-PL1
Schedule Snapshots: (optional) Define the cycle of snapshots.	Daily 00:00
11. Local Clone Configuration	
Item	Value
Source Volume Name: Select one of created volume for source.	V1-PL1
Source Volume Capacity: Check the capacity of source volume.	8TB
Target Volume Name: Select one of created volume for target.	T1-PL1
Target Volume Capacity: Check the capacity of target volume.	8TB
Schedule Local Clones: (optional) Define the cycle of local clones.	Daily 01:00

12. Remote Replication Configuration		
Item	Value	
Source Volume Name: Select one of created volume for source.	V1-PL1	
Source Volume Capacity: Check the capacity of source volume.	8TB	
Source iSCSI Port: iSCSI port of source unit. It can be auto or dedicated iSCSI port.	Auto	
Target iSCSI Port IP Addresses: iSCSI port IP addresses of target unit.		
Target	Controller 1	Controller 2 (optional)
IP Address	10.10.100.1	10.10.101.1
Target CHAP Username: (optional) CHAP username. The maximum length of the username is 223 characters. Valid characters are [A~Z a~z 0~9 ~!@#%&* _ += (){}[]; <> .? /].	chap2	
Target CHAP Password: (optional) CHAP password. The length of the password is between 12 to 16 characters. Valid characters are [A~Z a~z 0~9 ~!@#\$%^&* _ += ` \ (){}[]; ;' <> , .? /].	123456789012	
Target Volume Name: Select one of created volume for target.	RT1-PL1	
Target Volume Capacity: Check the capacity of target volume.	8TB	
Schedule Remote Replications: (optional) Define the cycle of remote replications.	Daily 02:00	
Traffic Shaping for Peak Hour: (optional) Limit the transfer rate at peak hour.	100MB	
Traffic Shaping for Off-peak Hour: (optional) Limit the transfer rate at off-peak hour.	200MB	
Off-peak Hour: (optional) Define the off-peak hours.	Mon. ~ Fri. PM10:00 ~ AM06:59 Sat. ~ Sun. AM00:00 ~ PM23:59	

3. Getting Started

After completing the configuration planning, it's time to power on the system, find your system and log into SANOS (SAN operating system). This chapter explains how to discover the SAN storage system and how to sign into SANOS.

3.1. Power on the Storage System

Before you power on the system, we assume that you have followed the following hardware installation document to finish the hardware installation.

- [XCubeSAN QIG \(Quick Installation Guide\)](#)
- [XCubeSAN Hardware Manual](#)



TIP:

Please double check all the cables (including power cords, Ethernet, fibre channel, and SAS cables) are connected properly, especially network cable connects to the management port. If everything is ready, now you can power on the system.

3.2. Discover the SAN Storage System

The default setting for the management IP address is DHCP. For users who are going to install at the first time, we provide the QFinder Java utility to search for QSAN products on the network and aid quick access to the login page of the SANOS web interface.

3.2.1. QFinder Utility

QFinder utility provides to search QSAN products on LAN. You can discover the management IP addresses of the storage systems via this utility. Please download QFinder utility from the following website.

<https://qsan.com/QFinder>

In addition, QFinder is a java based program. It is also a highly portable utility. To execute this program, JRE (Java Runtime Environment) is required. You can visit the following websites to download and install JRE.

<http://www.java.com/en/download/>

After JRE is installed, run the **QFinder.jar** program. The SAN storage system in your network will be detected and listed in the table.

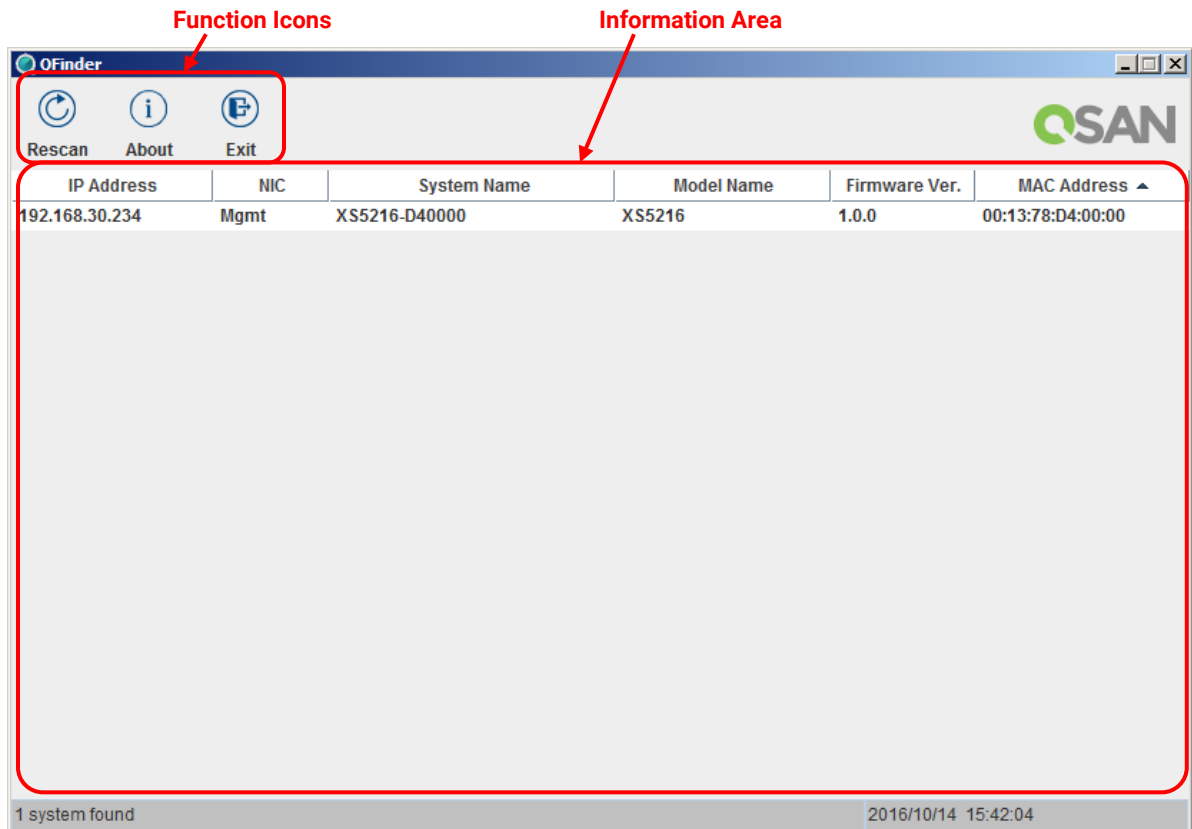

Figure 3-1 QFinder Utility

Take an example in Figure 3-1, the default setting of the management port IP address is gotten from the DHCP server, e.g., 192.168.30.234. The default system name is the model name plus the last 6 digits of serial number, e.g., XS5216-D40000. Double clicking the selected entry will automatically bring up the browser and display the login page.



INFORMATION:

QFinder utility works in the following network environments:

- Both the management port of the SAN storage system and the management computer are both on the same subnet domain of the LAN.
- The LAN works with or without DHCP server.
- If the LAN doesn't have a DHCP server, it still can work on zero-configuration networking. The management port will be assigned a fix IP address: 169.254.1.234/16. So you can configure the IP address of your management computer to the same subnet domain of the storage system, e.g.: 169.254.1.1/16. Then open a browser and enter <http://169.254.1.234> to go into the login page. For more information about zero configuration, please refer to: https://en.wikipedia.org/wiki/Zero-configuration_networking

3.3. Initial Setup

The Initial configuration wizard will guide the first time user to initialize and setup the system quickly. After discovering the storage system, please follow the steps to complete the initial configuration.

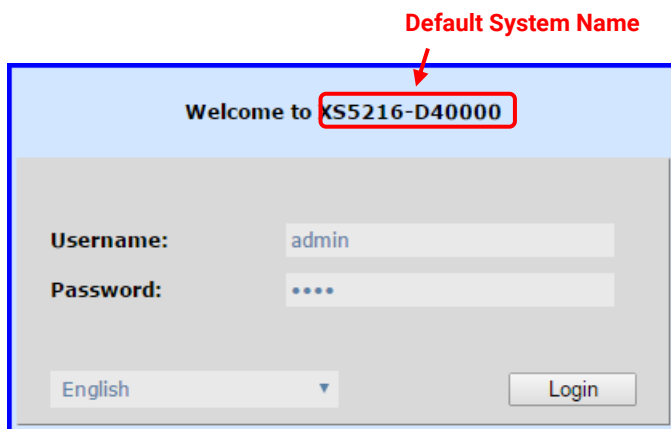

Figure 3-2 Login Page of web UI

1. To access the SANOS web interface, you have to enter a username and password. The initial defaults for administrator login are:

Username: admin

Password: 1234



TIP:

For existing users who are experienced, the Initial configuration wizard will not be shown again when you login next time, unless the system is **Reset to Defaults**. You may skip this section to start the operations of web UI in next chapter.

You can execute **Reset to Defaults** function in **SYSTEM SETTINGS** -> **Maintenance** -> **Reset to Defaults**. Please refer to the chapter 6.5.5, [Reset to Factory Default](#) section for more details.

Initial Configuration

System Setup
Network Setup
Summary

System Name
System Name : XCubeSAN_SANOS

Admin Password
New Password :
Confirm New Password :

Date and Time
 Keep Current Time : 2017/3/28 15:49:37
 Manual Setting :
 Synchronize with a NTP (Network Protocol Time) server automatically :
NTP Server : 0.pool.ntp.org

Time Zone
Time Zone : (GMT+08:00) Taipei

Next

Figure 3-3 Initial Configuration Step 1

2. Enter a **System Name**, for security reason, it's highly recommended to change system name. The maximum length of the system name is 32 characters. Valid characters are [A~Z | a~z | 0~9 | -_].

3. Change **Admin Password**, The maximum length of the password is 12 characters. Valid characters are [A~Z | a~z | 0~9 | ~!@#\$\$%^&* _-+=`|\(){}[];:"'<>.,?/].
4. Set the local **Date and Time**. Date and time can be set by manually or synchronized with a NTP (Network Time Protocol) server.
5. Select a **Time Zone** depending on your location.
6. Click the **Next** button to proceed.

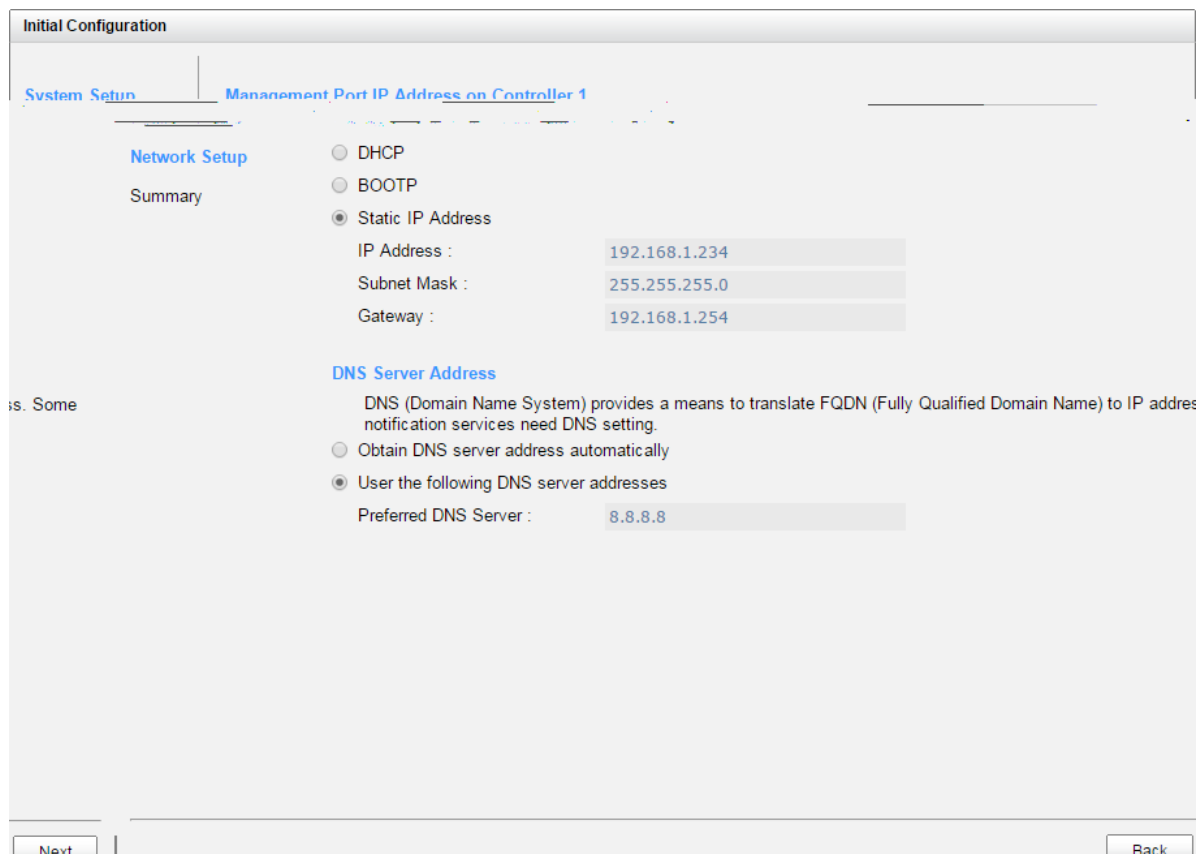

Figure 3-4 Initial Configuration Step 2

7. Assign an IP address for the management port by **DHCP**, **BOOTP**, or **Static IP Address**.



INFORMATION:

DHCP: The Dynamic Host Configuration Protocol is a standardized network protocol used on IP (Internet Protocol) networks for dynamically distributing network configuration parameters, such as IP addresses for interfaces and services. With DHCP, computers request IP addresses and networking parameters automatically from a DHCP server, reducing the need for a network administrator or a user to configure these settings manually.

BOOTP: Similar to DHCP, the Bootstrap Protocol is also a computer networking protocol used in Internet Protocol networks to automatically assign an IP address to network devices from a configuration server. While some parts of BOOTP have been effectively superseded by the DHCP, which adds the feature of leases, parts of BOOTP are used to provide service to the DHCP protocol. DHCP servers also provide legacy BOOTP functionality.

8. Assign a **DNS Server Address**. DNS (Domain Name System) provides a means to translate FQDN (Fully Qualified Domain Name) to IP address. Some notification services require DNS settings.
9. Click **Next** button to proceed.

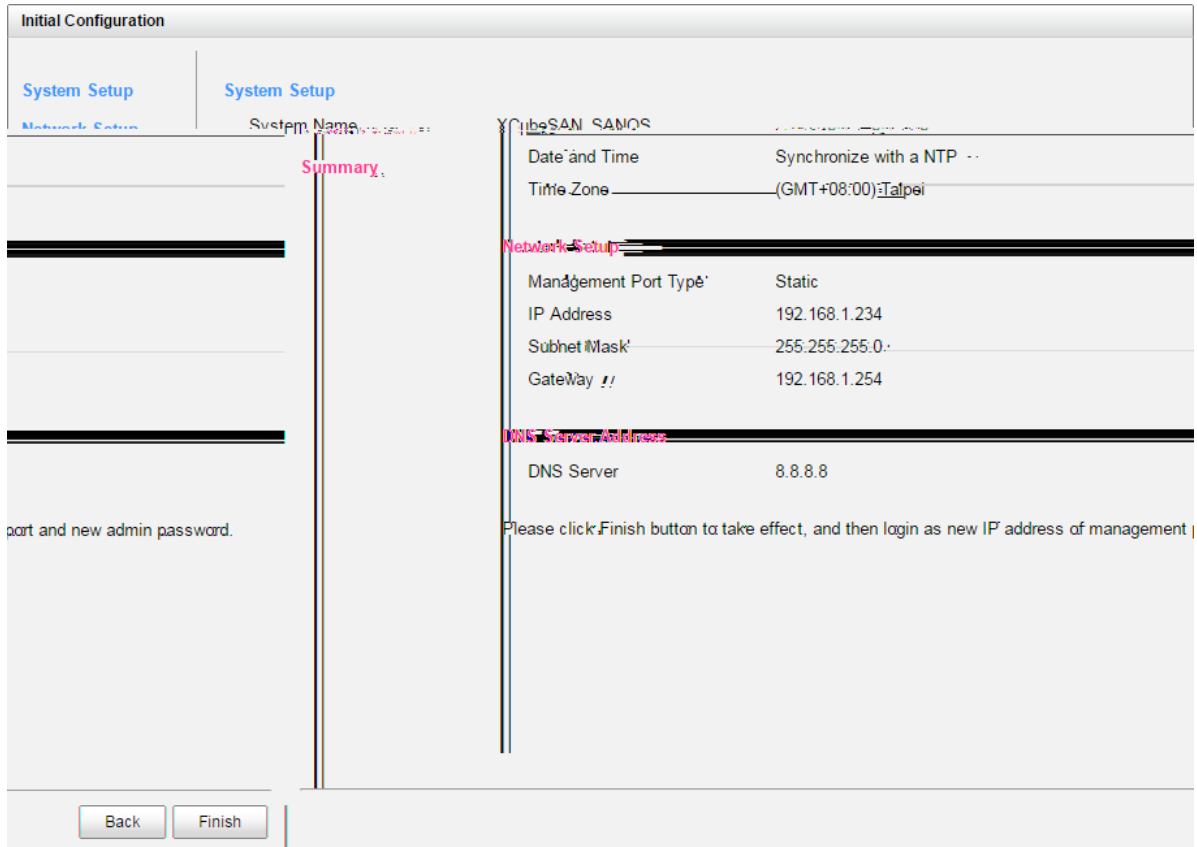

Figure 3-5 Initial Configuration Step 3

10. Verify all items, and then click the **Finish** button to complete the initial configuration. You have to login with the new IP address of the management port and new admin password next time.

4. SANOS User Interface

This chapter illustrates the web user interface of SANOS and provides a brief introduction to the SANOS 4.0 desktop function menus.

4.1. Accessing the Management Web UI

To access the management web user interface, open a supported web browser and enter the management IP address or Hostname of the system. The login panel is displayed, as shown in Figure 4-1.

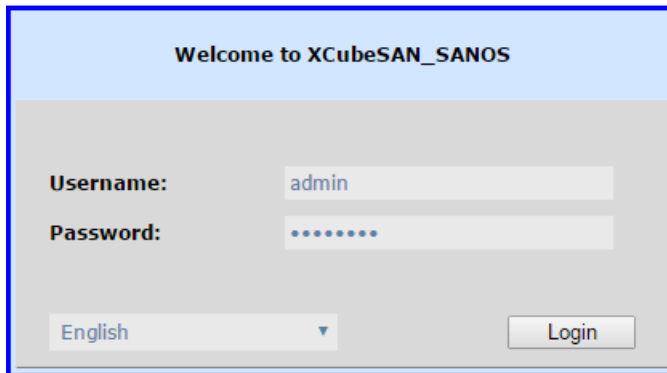

Figure 4-1 Login Page of web UI

To access the web user interface, you have to enter a username and password.

- **Username:** admin
- **Password:** <Your Password>



INFORMATION:

Supported web browsers:

- Google Chrome 45 or later.
 - Mozilla Firefox 45 or later.
 - Microsoft Internet Explorer 10 or later.
 - Apple Safari 8 or later.
-

4.2. SANOS 4.0 Desktop Panel

When the password has been verified, the home page is displayed. As shown in Figure 4-2, the SANOS 4.0 desktop panel has three main sections:

- Function Menus and Submenus
- Function Tabs
- Main Working Area

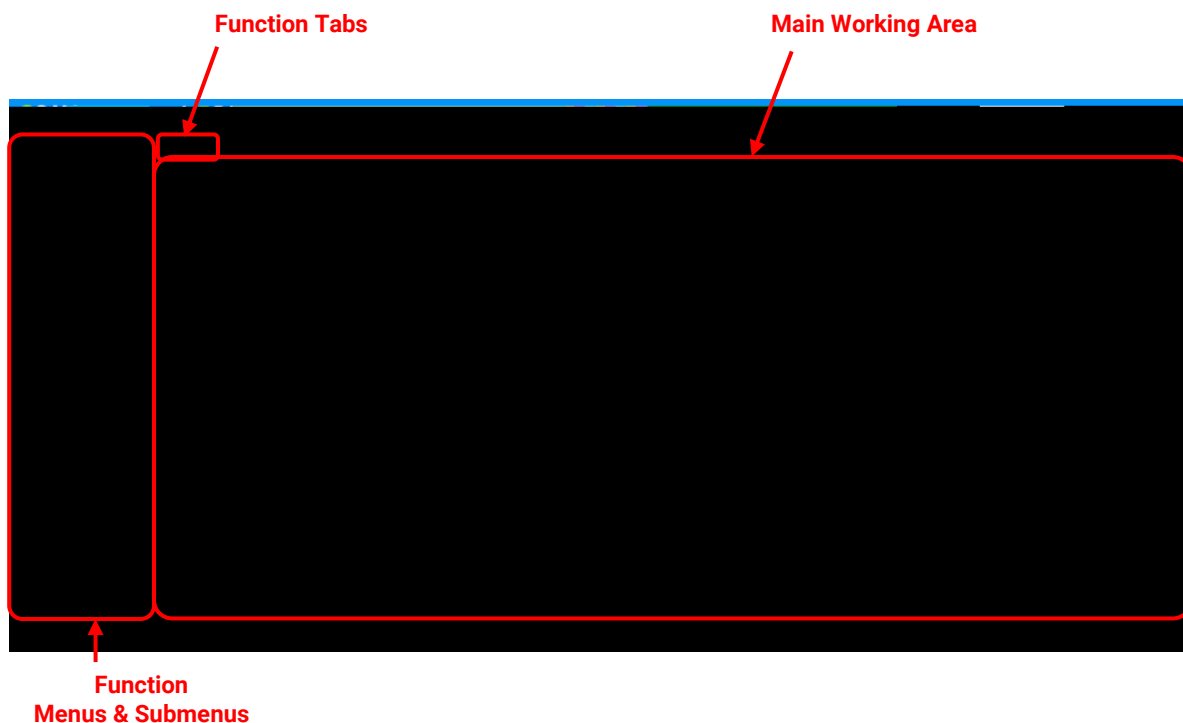

Figure 4-2 SANOS 4.0 Desktop Panel

All function menus are listed at the left side of the window. They are grouping by function icon and uppercase letter such as **DASHBOARD**, **SYSTEM SETTINGS** ...etc. The following is the second level function submenus such as **General Settings**, **Management Port** ...etc. This provides an efficient and quick mechanism for navigation.

Click a second level function submenu will appear the related user interface in main working area. Some function submenus have their sub functions and display at the top of function tabs. You may see all functions in Table 4-1.

The top-right corner displays a **Logout** button.







TIP:



For security reasons, always logout when you finish working in SANOS.

4.3. Function Menus

The following table shows all function menus and their function tabs for reference.

Table 4-1 SANOS 4.0 Function Menus

Function Menus	Function Tabs
 DASHBOARD Dashboard Hardware Monitoring	Dashboard Hardware Monitoring
 SYSTEM SETTING General Settings Management Port Power Settings Notifications Maintenance Disk Encryption	General Settings Management Port Boot Management Cache to Flash UPS Email Alert SNMP System Information Update Firmware Synchronization System Identification Reset to Defaults Configuration Backup Volume Restoration Reboot and Shutdown Authentication Key SEDs
 HOST CONNECTIVITY Overview iSCSI Ports Fibre Channel Ports	Overview iSCSI Ports iSCSI Settings iSCSI Targets CHAP Accounts Active Sessions Fibre Channel Ports
 STORAGE MANAGEMENT Disks Pools	Disks Disk Settings Pools Auto Tiering

Volumes	Volumes QoS Settings QoS Volumes
LUN Mappings	LUN Mappings
SSD Cache	SSD Cache Pools SSD Cache Statistics
 DATA BACKUP	
Snapshots	Snapshots
Remote Replications	Remote Replications
 VIRTUALIZATION	
VMware	VMware
Microsoft	Hyper-V
Citrix	Citrix
 MONITORING	
Log Center	Event Logs
Enclosures	Hardware Monitoring SES
Performance	Disk Volume iSCSI Fibre Channel

The following describes a brief introduction of desktop function menus.

4.3.1. Dashboard Menu

The **DASHBOARD** menu provides access to function menus of Dashboard and Hardware Monitoring.

Dashboard

Select **Dashboard** function menu provides summary of the overall system. For more information, please refer to the chapter 5.1, [Dashboard](#) section in the Dashboard chapter.

Hardware Monitoring

Select **Hardware Monitoring** function menu provides summary enclosure information. For more information, please refer to the chapter 5.2, [Hardware Monitoring](#) section in the Dashboard chapter.

4.3.2. System Settings Menu

The **SYSTEM SETTINGS** menu provides access to function menus of General, Management Port, Power, Notification, and Maintenance.

General Settings

Select **General Settings** function menu to setup general system settings. For more information, please refer to the chapter 6.1, [General System Settings](#) section in the System Settings chapter.

Management Port

Select **Management Port** function menu to setup IP address and DNS settings of management port. For more information, please refer to the chapter 6.2, [Management Port Settings](#) section in the System Settings chapter.

Power Settings

Select **Power Settings** function menu to setup boot management which includes auto shutdown, wake on LAN, and wake on SAS ...etc., view the status of cache to flash, and setup UPS for power outage. For more information, please refer to the chapter 6.3, [Power Settings](#) section in the System Settings chapter.

Notifications

Select **Notifications** function menu to setup notification settings of email, syslog, popup alert, LCM alert, and SNMP trap. For more information, please refer to the chapter 6.4, [Notification Settings](#) section in the System Settings chapter.

Maintenance

Select **Maintenance** function menu to view system information, update system firmware and check firmware synchronization, system identification, reset to system defaults, import and export configuration files, restore volumes if an accidental delete occurs, reboot and shutdown. For more information, please refer to the chapter 6.5, [Maintenance](#) section in the System Settings chapter.

Disk Encryption

Select **Disk Encryption** function menu to setup the authentication key and configure SEDs. For more information, please refer to the chapter 14, [SED and ISE Support](#) chapter.

4.3.3. Host Configuration Menu

The **HOST CONFIGURATION** menu provides access to function menus of Overview, iSCSI Port, and Fibre Channel Ports which is visible when fibre channel host cards are installed.

Overview

Select **Overview** function menu to view all host connectivity which includes status and settings of all host cards. For more information, please refer to the chapter 7.2, [Host Connectivity Overview](#) section in the Host Configuration chapter.

iSCSI Ports

Select **iSCSI Ports** function menu to setup iSCSI port settings, including iSCSI port IP address, link aggregation, VLAN ID, jumbo frame, iSNS server, iSCSI targets, CHAP accounts, and view iSCSI active sessions. For more information, please refer to the chapter 7.3, [Configure for iSCSI Connectivity](#) section in the Host Configuration chapter.

Fibre Channel Ports

Select **Fibre Channel** function menu to setup fibre channel port settings, including link speed, topology, target configuration, and clear counters of fibre channel statistics. For more information, please refer to the chapter 7.4, [Configure for Fibre Channel Connectivity](#) section in the Host Configuration chapter.

4.3.4. Storage Management Menu

The **STORAGE MANAGEMENT** menu provides access to function menus of Disks, Pools, Volumes, and Mappings.

Disks

Select **Disks** function menu to view status of disk drives and S.M.A.R.T. (Self-Monitoring Analysis and Reporting Technology) information. For more information, please refer to the chapter 8.3, [Working with Disk Drives](#) section in the Storage Management chapter.

Pools

Select **Pools** function menu to configure storage pools. For more information, please refer to the chapter 8.4, [Configuring Thick Provisioning Pools](#) section in the Storage Management

chapter, chapter 9.3, [Configuring Thin Provisioning Pools](#) section in the Thin Provisioning chapter, chapter 11.3, [Configuring Auto Tiering Pools](#) section in the Auto Tiering chapter.

Volumes

Select **Volumes** function menu to configure volumes, manage clone tasks, and configure QoS (Quality of Service). For more information, please refer to the chapter 8.5, [Configuring Volumes](#) section in the Storage Management chapter, the chapter 12.2, [Managing Local Clones](#) section in the Data Backup chapter, and the chapter 15, [QoS \(Quality of Service\)](#) chapter.

LUN Mappings

Select **LUN Mappings** function menu to configure LUN mappings. For more information, please refer to the chapter 8.6, [Configuring LUN Mappings](#) section in the Storage Management chapter.

SSD Cache

Select **SSD Cache** function menu to configure SSD cache pools. For more information, please refer to the chapter 10.3, [Configuring SSD Cache](#) section in SSD Cache chapter.

4.3.5. Data Backup Menu

The **DATA BACKUP** menu provides access to function menus of Snapshots and Replications.

Snapshots

Select **Snapshots** function menu to manage snapshots, including setting up snapshot space, taking snapshots, rollback to a snapshot, and scheduling snapshots. For more information, please refer to the chapter 12.1, [Managing Snapshots](#) section in the Data Backup chapter.

Replications

Select **Replications** function menu to manage remote replications, including setup replication tasks, schedule replication tasks, configure shaping settings. For more information, please refer to the chapter 12.3, [Managing Remote Replications](#) section in the Data Backup chapter.

4.3.6. Virtualization Menu

The **VIRTUALIZATION** menu provides access to function menus of VMware, Microsoft, and Citrix.

VMware

Provide information of supported VMware integration of storage, such as VAAI (VMware vSphere Storage APIs for Array Integration).

Microsoft

Provide information of supported Microsoft Windows feature of storage, such as ODX (Offloaded Data Transfer).

Citrix

Provide information of Citrix XenServer platform and its compatible version.

4.3.7. Monitoring Menu

The **MONITORING** menu provides access to function menus of Log Center, Enclosure, and Performance.

Log Center

Select **Log Center** function menu to view event logs, download event logs, or clear event logs. Also mute buzzer if system happens alerts. For more information, please refer to the chapter 13.1, [Log Center](#) section in the Monitoring chapter.

Enclosures

Select **Enclosures** function menu to view hardware monitor status and enable SES (SCSI Enclosure Services). For more information, please refer to the chapter 13.2, [Hardware Monitor](#) section in the Monitoring chapter.

Performance

Select **Performance** function menu to view system performance. For more information, please refer to the chapter 13.3, [Performance Monitor](#) section in the Monitoring chapter.

4.4. Accessing the Management USB LCM

Optionally, we provide a portable USB LCM (LCD Control Module) for simple management. To access the management USB LCM, plug it into the USB port of the right ear in the front panel.



Figure 4-3 Portable USB LCM



INFORMATION:

For the USB port in front panel, please refer to the chapter 2, System Components Overview in the [XCubeSAN Hardware Manual](#).

After plugging the USB LCM into the system, the LCD screen shows the management port IP address and the system model name.

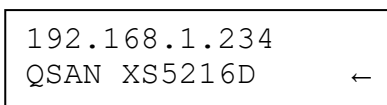

Figure 4-4 USB LCM Screen

To access the LCM options, use the **ENT** (Enter) button, **ESC** (Escape) button, **▲** (up) and **▼** (down) to scroll through the functions. **MUTE** button to mute the buzzer when the system alarms. If there are event logs occurred, events will be displayed on the first line of the LCM.



TIP:

The event alert settings can be changed, please refer to the chapter 6.4.2, [Alert Settings](#) section in the System Settings chapter.

This table describes the function of each item.

Table 4-2 USB LCM Function List

Function	Description
System Info.	Display system information including firmware version and memory size.
Reset/Shutdown	Reset or shutdown the system.
View IP Setting	Display current IP address, subnet mask, and gateway.
Change IP Config	Set IP address, subnet mask, and gateway. There are three options of DHCP, BOOTP, or static IP address.
Enc. Management	Show the enclosure data of disk drive temperature, fan status, and power supply status.
Reset to Default	<p>Reset the system to default settings. The default settings are:</p> <ul style="list-style-type: none"> • Reset Management Port IP address to DHCP, and then fix IP address: 169.254.1.234/16. • Reset admin's Password to 1234. • Reset System Name to model name plus the last 6 digits of serial number. For example: XS5216-123456. • Reset IP addresses of all iSCSI Ports to 192.168.1.1, 192.168.2.1, ... etc. • Reset link speed of all Fibre Channel Ports to Automatic. • Clear all access control settings of the host connectivity.



INFORMATION:

DHCP: The Dynamic Host Configuration Protocol is a standardized network protocol used on IP (Internet Protocol) networks for dynamically distributing network configuration parameters, such as IP addresses for interfaces and services. With DHCP, computers request IP addresses and networking parameters automatically from a DHCP server, reducing the need for a network administrator or a user to configure these settings manually.

BOOTP: Similar to DHCP, the Bootstrap Protocol is also a computer networking protocol used in Internet Protocol networks to automatically assign an IP address to network devices from a configuration server. While some parts of BOOTP have been effectively superseded by the DHCP, which adds the feature of leases, parts of BOOTP are used to provide service to the DHCP protocol. DHCP servers also provide legacy BOOTP functionality.

This table displays the LCM menu hierarchy for your reference when you operate USB LCM.

Table 4-3 USB LCM Menu Hierarchy

Menu	L1	L2	L3	L4	
<IP Addr> QSAN <Model> ▲▼	System Info.	Firmware Version <n.n.n>			
		RAM Size <nnnn> MB			
			▲Yes No▼		
	Reset / Shutdown	Reset		▲Yes No▼	
		Shutdown		▲Yes No▼	
	View IP Setting	IP Config <Static IP / DHCP / BOOTP>			
		IP Address <192.168.001.234>			
		IP Subnet Mask <255.255.255.0>			
		IP Gateway <xxx.xxx.xxx.xxx>			
	Change IP Config	DHCP			
		BOOTP			
		Static IP	IP Address		Adjust IP address
			IP Subnet Mask		Adjust Submask IP
			IP Gateway		Adjust Gateway IP
	Apply IP Setting			▲Yes No▼	
	Enc. Management	Phy. Disk Temp.	Local Slot <n>: <nn> (C)		
		Cooling	Local FAN<n>: <nnnnn> RPM		
		Power Supply	Local		

			PSU<n>: <status>	
	Reset to Default	▲Yes No▼		

5. Dashboard

The **DASHBOARD** function menu provides submenus of **Dashboard** and **Hardware Monitoring**. These pages may help user to quickly view the basic information and system health.

5.1. Dashboard

Select the **Dashboard** function submenu to show summary of overall system. It's divided into four blocks in the main working area. There are system information, storage view, performance, and event logs.

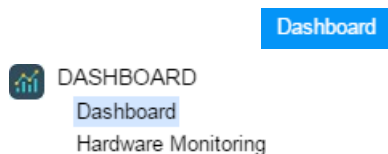

Figure 5-1 Dashboard Function Submenu

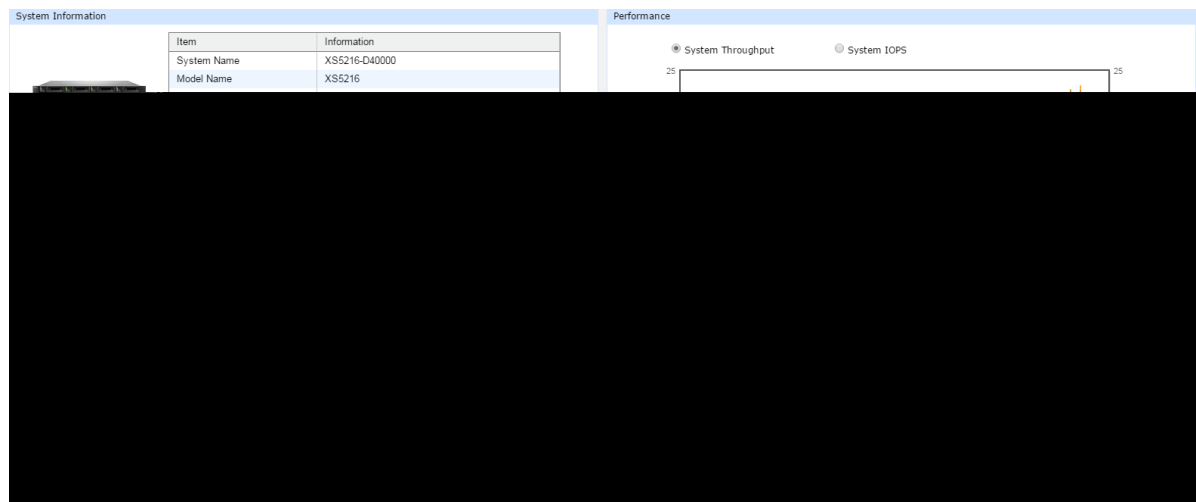

Figure 5-2 Dashboard

System Information

The system information block displays the basic information of the system. In addition, clicking [More...](#) will pop up a window for more details.

Item	Information
System Name	XS5216-D40000
Model Name	XS5216
Backplane ID	QW316
System Serial Number	QW3160160I0021001
Firmware Version	1.2.0
System Controller Status	Dual Controller, Active, Active
System Health	Good

[More...](#)

Figure 5-3 System Information Block in the Dashboard

This table shows the column descriptions.

Table 5-1 System Information Block Descriptions

Column Name	Description
System Availability Status	<p>The status of system availability:</p> <ul style="list-style-type: none"> Dual Controller, Active/Active: Dual controllers and expansion units are in normal stage. Dual Controller, Degraded: In dual controller mode, one controller or one of expansion unit fails or they have been plugged out. Please replace or insert a good controller. Dual Controller, Lockdown: In dual controller mode, the configurations of two controllers are different, including the memory capacity, host cards, and controller firmware version. Please check the hardware configurations of two controllers or execute firmware synchronization. Single Controller: Single controller mode.
System Health	<p>The status of system health:</p> <ul style="list-style-type: none"> Good: The system is good. Fan Fault: A fan module has failed or is no longer connected. PSU Fault: A power supply has failed or is no longer connected.

- **Temperature Fault:** Temperature is abnormal.
- **Voltage Fault:** Voltage values are out of range.
- **UPS Fault:** UPS connection has failed.

Clicking [More...](#) will pop up a window of system information details.

The screenshot shows a 'System Information' popup window. It is divided into several sections:

- System:** A table with columns 'Item' and 'Information'. The first row shows 'System Name' as 'SANOSccc'.
- System Details:** A list of system attributes including Model Name (XS8216), System Serial Number (QW31601600), System Controller Status (Dual Controller), and Master Controller (Controller 1).
- Controller 1:** A table with columns 'Item' and 'Information' listing details for Controller 1, such as Controller Serial Number (50013780080A), CPU (Intel(R) Xeon(F)), Memory (8 GB), and various firmware versions.
- Controller 2:** A table with columns 'Item' and 'Information' listing details for Controller 2, including Controller Serial Number (50013780080A), CPU (Intel(R) Xeon(F)), and Memory (8 GB).
- Processor Information:** On the left side, there are sections for processors, including 'Processor D-1500 4 Cores' and 'Processor D-1500 8 Cores'.
- Close Button:** A 'Close' button is located at the bottom center of the window.

Figure 5-4 System Information Popup Window

Click the **Close** button to exit the window.

Storage View

The storage view block displays the basic information of storage. In addition, clicking pool column will pop up a window for more details.

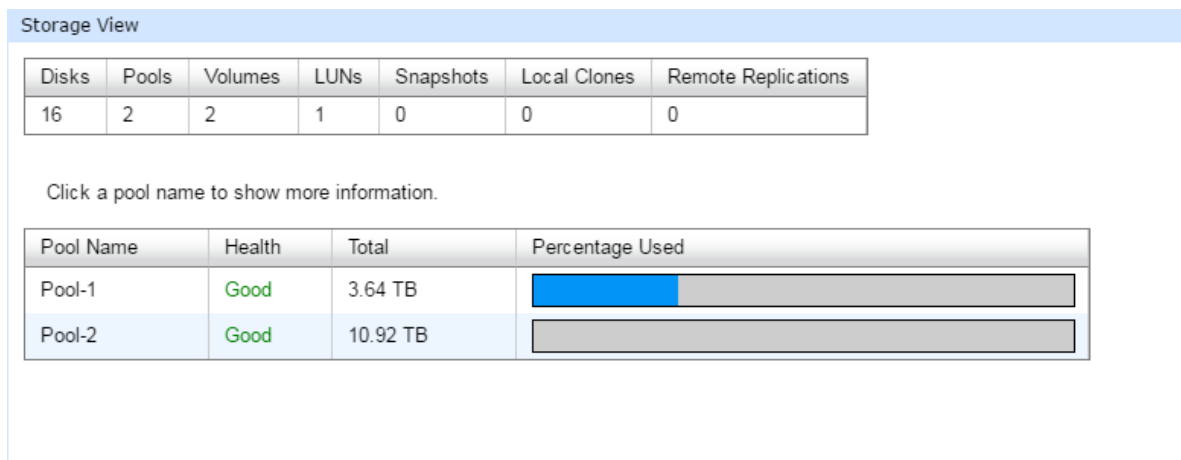

Figure 5-5 System View Block in the Dashboard

The top table displays sum of disks, pools, volumes, LUN mappings, snapshots, clones, and remote replications in system. The following table displays all created pools and its basic information.

Table 5-2 Storage View Block Descriptions

Column Name	Description
Name	Pool name.
Health	The health of the pool: <ul style="list-style-type: none"> Good: The pool is good. Failed: The pool has failed. Degraded: The pool is not healthy and not completed. The reason could be lack of disk(s) or have failed disk.
Total	Total capacity of the pool.
Percentage Used	Mouse over the Blue block will display the percentage of used. And the Gray block will display the percentage of available.

Click any one of the pool names such as Pool-1 in Figure 5-4 will pop up the detailed pool information.

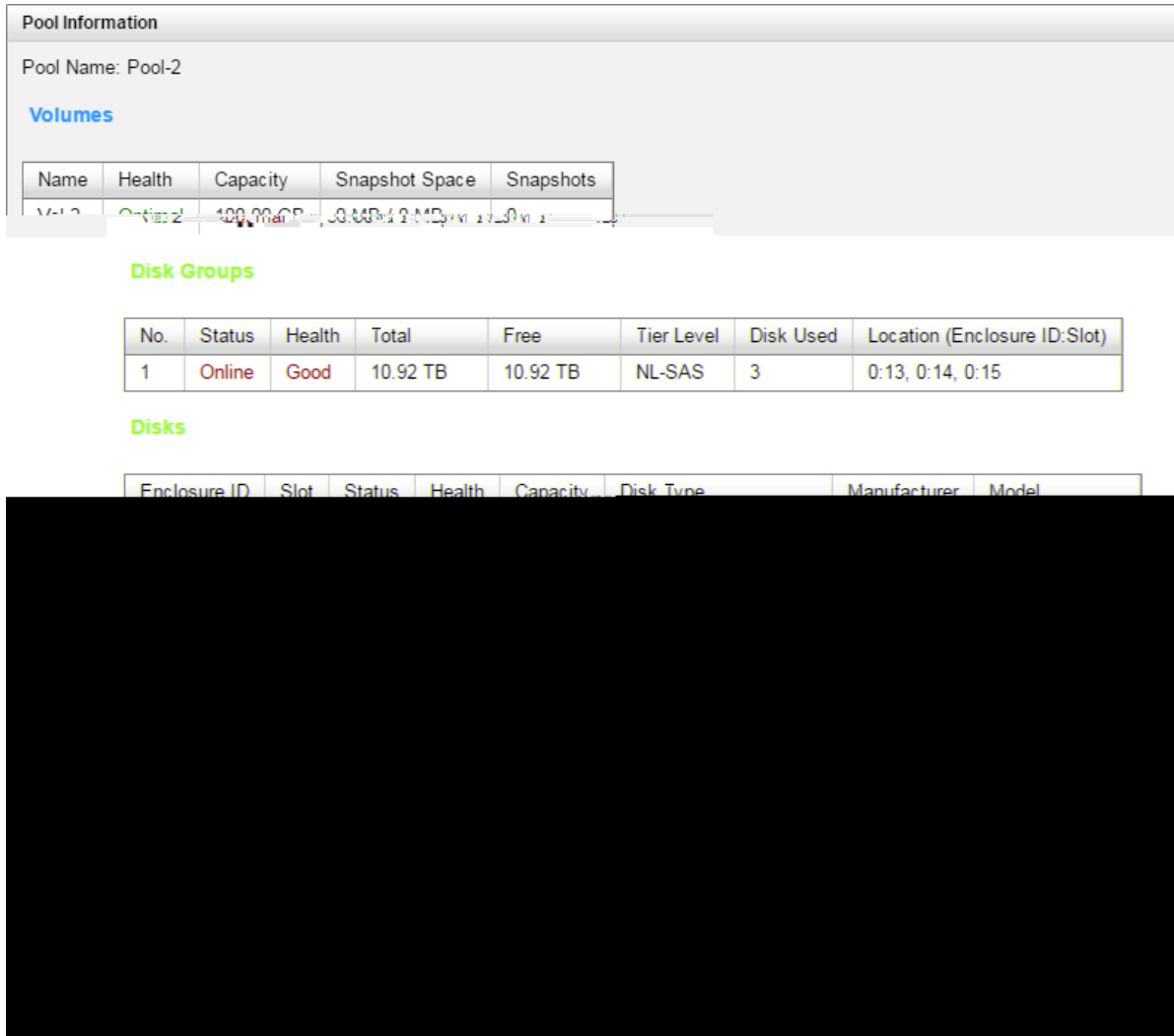

Figure 5-6 Pool Information Popup Window

This table shows the column descriptions.

Table 5-3 Volume Column Descriptions

Column Name	Description
Name	Volume name.
Health	<p>The health of the volume:</p> <ul style="list-style-type: none"> Optimal: the volume is working well and there is no failed disk in the RG. Failed: the pool disk of the VD has single or multiple failed disks than its RAID level can recover from data loss. Degraded: At least one disk from the RG of the Volume has failed

	<p>or plugged out.</p> <ul style="list-style-type: none"> • Non-optimal: the volume has experienced recoverable read errors. After passing parity check, the health will become Optimal.
Capacity	Total capacity of the volume.
Used	Used capacity of the volume.
Used %	Used percentage of the volume.
Snapshot space	Used snapshot space / Total snapshot space. The first capacity is current used snapshot space, and the second capacity is reserved total snapshot space.
Snapshots	The quantity of snapshot of the volume.

Table 5-4 Disk Group Column Descriptions

Column Name	Description
No	The number of disk group.
Status	<p>The status of the disk group:</p> <ul style="list-style-type: none"> • Online: The disk group is online. • Offline: The disk group is offline. • Rebuilding: The disk group is being rebuilt. • Migrating: The disk group is being migrated. • Relocating: The disk group is being relocated. • EE Rebuilding: The disk group is being RAID EE rebuilt.
Health	<p>The health of the disk group:</p> <ul style="list-style-type: none"> • Good: The disk group is good. • Failed: The disk group has failed. • Degraded: The pool is unhealthy and incomplete. The cause may be a disk loss or failure.
Total	Total capacity of the disk group.
Free	Free capacity of the disk group.
Disks Used	The quantity of disk drives in the disk group.
Location	Disk location represents in Enclosure ID:Slot.

Table 5-5 Disk Column Descriptions

Column Name	Description
Enclosure ID	The enclosure ID.
Slot	The position of the disk drive.
Status	The status of the disk drive:

	<ul style="list-style-type: none"> • Online: The disk drive is online. • Missing: The disk drive is missing in the pool. • Rebuilding: The disk drive is being rebuilt. • Transitioning: The disk drive is being migrated or is replaced by another disk when rebuilding occurs. • Scrubbing: The disk drive is being scrubbed. • Check Done: The disk drive has been checked the disk health. • Copying Back: The disk drive is being copied back.
Health	<p>The health of the disk drive:</p> <ul style="list-style-type: none"> • Good: The disk drive is good. • Failed: The disk drive has failed. • Error Alert: S.M.A.R.T. error alerts. • Read Errors: The disk drive has unrecoverable read errors.
Capacity	The capacity of the disk drive.
Disk Type	<p>The type of the disk drive:</p> <ul style="list-style-type: none"> • [SAS HDD NL-SAS HDD SAS SSD SATA SSD] • [12.0Gb/s 6.0Gb/s 3.0Gb/s 1.5Gb/s]
Manufacturer	The manufacturer of the disk drive.
Model	The model name of the disk drive.

Click the **Close** button to exit the window.

Performance

The performance block displays the system throughput or system IOPS of all front-end ports for reference.

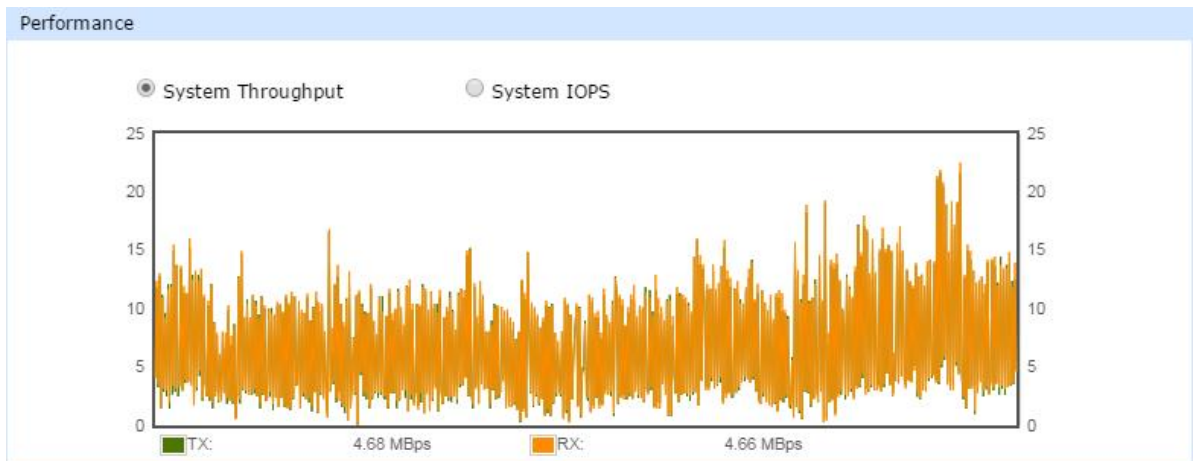

Figure 5-7 Performance Block in the Dashboard

When selecting System Throughput:

- **TX:** Green line is transmitting throughput performance data. Unit of measure is MBps (Mega Byte Per Second).
- **RX:** Amber line is receiving throughput performance data. Unit of measure is MBps (Mega Byte Per Second).

When selecting System IOPS:

- **IOPS:** Green line is total IOPS (Input/Output Per Second). Unit is the number of times.

Event Logs

The event log block displays the recent 5 event logs. In addition, clicking [More...](#) will link to **Event Logs** function tab of **Log Center** function submenu to view complete event logs.

Type	Time	Content
Information	Sun, 18 Sep 2016 11:09:30	[CTR1] Virtual disk 'Vol-1' has started initialization.
Information	Sun, 18 Sep 2016 11:09:30	[CTR1] Virtual disk 'Vol-1' finished erasing process.
Information	Sun, 18 Sep 2016 11:09:30	[CTR1] Virtual disk 'Vol-1' started erasing process.
Information	Sun, 18 Sep 2016 11:09:30	[CTR1] Virtual disk 'Vol-1' has been created.
Information	Sun, 18 Sep 2016 11:09:07	[CTR1] RAID group 'Pool-1' has been created.

[More...](#)

Figure 5-8 Event Logs in the Dashboard



TIP:

The displaying types of the event logs are the same as the event level filter in Event Logs, please refer to the chapter 13.3, [Log Center](#) section in the Monitoring chapter.

5.2. Hardware Monitoring

Select the **Hardware Monitoring** function submenu to show summary status of all enclosures. There are current voltage, temperature, status of fan module, and power supply. In addition, clicking [More...](#) will pop up a window for more details.

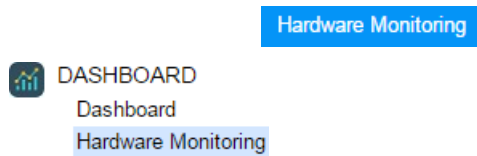



Figure 5-9 Hardware Monitoring Function Submenu

Head Unit



System

Item	Information
Enclosure ID	0
System Serial Number	QW316016010021001
System Name	XS5216-D40000
Model Name	XS5216

XS5216

Backplane ID	QW316
System Health	Good

Controller 1

Item	Information
Voltage	Good
Temperature	Good

Controller 2

Item	Information
Voltage	Good
Temperature	Good

Backplane

Item	Information
Voltage	Good
Temperature	Good

System Components

Item	Information
Power Supply	Good
Fan Module	Good

More to Flash

Item	Information
Power Module	Good
Flash Module	Good

Cached

Item	Information
Power	Good
Flash	Good

Figure 5-10 Hardware Monitoring

There are many voltage and temperature sensors on the controller and backplane. If the statuses of every sensor are **Good**, the information in this page displays **Good**. On the other hand, if anyone is not good, it will display **Failed**. So you may click **More...** to see details on what component has a fault.

Clicking **More...** of every enclosure will pop up a window of enclosure status in detail.

Head Unit							
Controller 1							
Type	Item	Value	Low Critical	High Warning	High Warning	High Critical	Status
Voltage	+3.3V	+3.33 V	+3.04 V	+3.14 V	+3.47 V	+3.56 V	Good
Voltage	Standby +3.3V	+3.34 V	+3.04 V	+3.14 V	+3.47 V	+3.56 V	Good
Voltage	CPU 10GbE MAC	+1.06 V	+0.98 V	+1.02 V	+1.07 V	+1.12 V	Good
Voltage	CPU South Complex	+1.00 V	+0.90 V	+0.95 V	+1.05 V	+1.10 V	Good
Voltage	CPU KR/KX PHY	+1.29 V	+1.23 V	+1.24 V	+1.35 V	+1.37 V	Good
Voltage	SAS Expander	+0.90 V	+0.81 V	+0.85 V	+0.95 V	+0.99 V	Good
Voltage	SAS IOC	+0.96 V	+0.87 V	+0.92 V	+1.03 V	+1.08 V	Good
Voltage	Battery	+3.26 V	+2.00 V	+2.30 V	+3.47 V	+3.56 V	Good
Voltage	+1.2V	+1.26 V	+1.08 V	+1.13 V	+1.28 V	+1.32 V	Good
Voltage	+0.82V	+0.82 V	+0.73 V	+0.77 V	+0.86 V	+0.90 V	Good
Voltage	VCore	+1.81 V	+1.40 V	+1.45 V	+1.97 V	+2.00 V	Good
Temperature	CPU	60.0°C / 140.0°F	0.0°C / 32.0°F	5.0°C / 41.0°F	82.0°C / 179.6°F	95.0°C / 203.0°F	Good
Temperature	SAS Expander	73.3°C / 163.9°F					

Low-Critical	High-Warning	High Warning	High Critical	Status
+3.04 V	+3.14 V	+3.47 V	+3.56 V	Good
+3.04 V	+3.14 V	+3.47 V	+3.56 V	Good
+0.98 V	+1.02 V	+1.07 V	+1.12 V	Good
+0.90 V	+0.95 V	+1.05 V	+1.10 V	Good
+1.23 V	+1.24 V	+1.35 V	+1.37 V	Good
+0.81 V	+0.85 V	+0.95 V	+0.99 V	Good

Type	Item	Value
Voltage	+3.3V	+3.32 V
Voltage	Standby +3.3V	+3.33 V
Voltage	CPU 10GbE MAC	+1.05 V
Voltage	CPU South Complex	+1.00 V
Voltage	CPU KR/KX PHY	+1.28 V
Voltage	SAS Expander	+0.89 V

Figure 5-11 Head Unit Popup Window

Click the **Close** button to exit the window.

6. System Settings

This chapter describes the details of system settings. The **SYSTEM SETTINGS** function menu provides submenus of **General Settings**, **Management Port**, **Power Settings**, **Notification**, **Maintenance**, and **Disk Encryption**.

6.1. General System Settings

Select the **General Settings** function submenu to show the information of system name, date and time, and login related settings. The system name, administrator's password, user's password, date and time, and the login options can be changed as required.

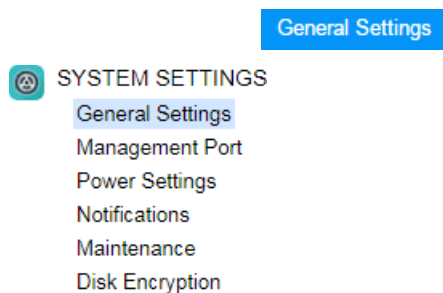

Figure 6-1 General Function Submenu



TIP:

Mouse over the icon  can get online help.

System Name

System Name: i

Admin Password

Change Admin Password

Current Password: i

New Password:

Confirm New Password:

User Password

Change User Password

New Password:

Confirm New Password:

Date and Time

Change Date and Time

Current Time:

Time Zone: ▼

Setup Date and Time Manually

Date: / /

16 ▼ : 29 ▼ : 18 ▼ Time:

NTP

NTP Server:

i

i

Login Options

Auto Logout:

Login Lock:

Figure 6-2 General Settings

Options of System Settings

The options are available in this tab:

- **System Name:** Change the system name, highlight the old name and type in a new one. Maximum length of the system name is 32 characters. Valid characters are [A~Z | a~z | 0~9 | -_].
- **Change Admin Password:** Check it to change administrator password. The maximum length of the password is 12 alphanumeric characters. Valid characters are [A~Z | a~z | 0~9 | ~!@#\$%^&* _+=` \(){}[]:;'"<>.,?/].
- **Change User Password:** Check it to change user password. The maximum length of the password is 12 alphanumeric characters. Valid characters are [A~Z | a~z | 0~9 | ~!@#\$%^&* _+=` \(){}[]:;'"<>.,?/].
- **Date and Time:** Check **Change Date and Time** button and change the current date, time and time zone as required. Date and time can be set by manually or synchronized from a NTP (Network Time Protocol) server.
- **Auto Logout:** When the auto logout option is enabled, you will be logged out of the admin interface after the time specified. There are Disabled (default), 5 minutes, 30 minutes, and 1 hour options.
- **Login Lock:** When the login lock is enabled, the system allows only one user to login to the web UI at a time. There are Disabled (default) and Enabled options.

When finished, click the **Apply** button to take effect.

6.2. Management Port Settings

Select the **Management Port** function submenu to show the information of the management ports. MAC address is displayed for reference and it is used on wake-on-LAN feature. IP address, DNS server, and service ports can be modified according to the management purpose.

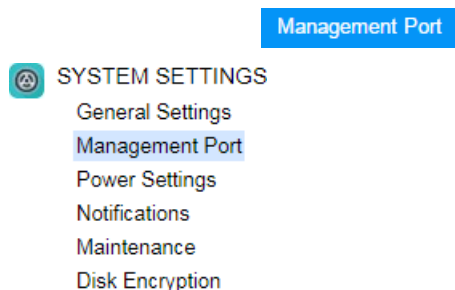

Figure 6-3 Management Port Function Submenu

Enable Dual Management Ports i

Show Information for: Controller 1 ▾

MAC Address Controller 1

MAC Address: 00:13:78:D4:00:00

IP Address

DHCP

BOOTP

Static IP Address

34 IP Address: 192.168.1.2

.0 Subnet Mask: 255.255.255

54 Gateway: 192.168.1.2

DNS Server Address

Address: 8.8.8.8

Service Ports

Enable HTTP Service

(Default Port : 80) HTTP Port: 80

Enable HTTPS Service

(Default Port : 443) HTTPS Port: 443

Enable SSH Service

(Default Port : 22) SSH Port: 22

Figure 6-4 Management Port settings

Options of Management Port Settings

The options are available in this tab:

- Enable Dual Management Ports:** This is for dual controller models. When the setting is enabled, both management ports of the controllers have their own IP addresses and MAC addresses, and both are active. If the setting is disabled, only the management port of the master controller is active, the other one is on standby. Both controller management ports share the same IP address and MAC address. The management port

fails over to the slave controller when the master controller goes offline, either planned or unplanned.



INFORMATION:

For deployment of management ports, please refer to the chapter 4 Deployment Types and Cabling in the [XCubeSAN Hardware Manual](#).

- **MAC Address:** Display the MAC address of the management port.
- **IP Address:** The option can change IP address for remote administration usage. There are three options for **DHCP**, **BOOTP**, or **Static IP Address**.



INFORMATION:

DHCP: The Dynamic Host Configuration Protocol is a standardized network protocol used on IP (Internet Protocol) networks for dynamically distributing network configuration parameters, such as IP addresses for interfaces and services. With DHCP, computers request IP addresses and networking parameters automatically from a DHCP server, reducing the need for a network administrator or a user to configure these settings manually.

BOOTP: Similar to DHCP, the Bootstrap Protocol is also a computer networking protocol used in Internet Protocol networks to automatically assign an IP address to network devices from a configuration server. While some parts of BOOTP have been effectively superseded by the DHCP, which adds the feature of leases, parts of BOOTP are used to provide service to the DHCP protocol. DHCP servers also provide legacy BOOTP functionality.

- **DNS Server Address:** DNS (Domain Name System) provides a means to translate FQDN (Fully Qualified Domain Name) to IP address. Some notification services need DNS setting. Enter an IP address of DNS server here.
- **Service Ports:** Uncheck to disable the service ports of **HTTP**, **HTTPS**, and **SSH**. If the default port numbers of the service ports are not allowed on your network environment, they can be changed here.

When finished, click the **Apply** button to take effect.

6.3. Power Settings

The **Power Settings** function submenu provides **Boot Management**, **Cache to Flash**, and **UPS** function tabs to show information and configuration setup.

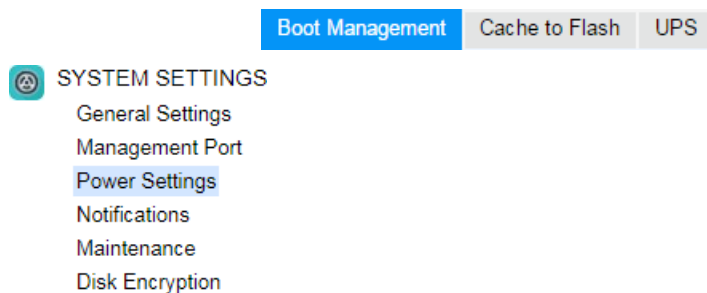

Figure 6-5 Power Settings Function Submenu

6.3.1. Boot Management Settings

Select the **Boot Management** function tab in the **Power Settings** function submenu to enable or disable options about boot.

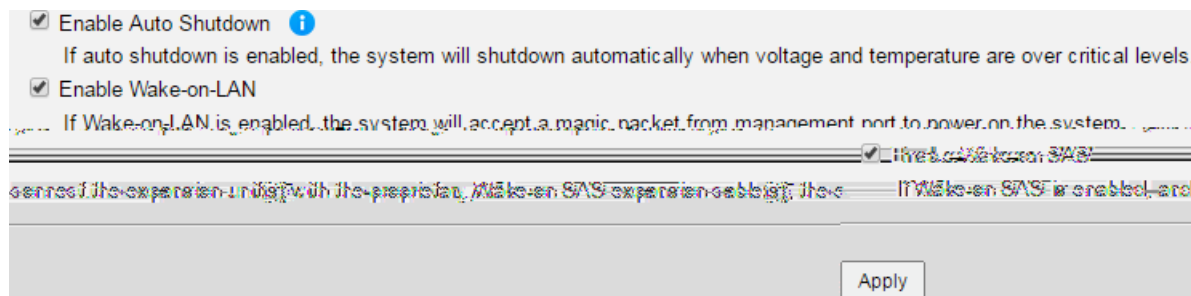

Figure 6-6 Boot Management Settings

Options of Boot Management Settings

The options are available in this tab:

- **Enable Auto Shutdown:** Check to enable the auto shutdown feature. If it is enabled, the system will shut down automatically when the voltage and temperature exceed a critical level.

**TIP:**

For better protection and to avoid a single short period of abnormal voltage or temperature, enabling the setting could trigger an automatic shutdown. This is done using several sensors placed on key systems that the system checks every 30 seconds for present voltages or temperatures. The following items are trigger conditions.

- The value of voltage or temperature is lower than **Low Critical** or higher than **High Critical**.
- When one of these sensors reports above the threshold for three continuous minutes, the system will be shutdown automatically.

For more information about critical values, please refer to the chapter 13.2.1, [Hardware Monitoring](#) section in the Monitoring chapter.

- **Enable Wake-on-LAN:** Check to enable the wake-on-LAN feature. If it is enabled, the system will accept a magic packet from the management port to power on the system.
-

**TIP:**

To execute wake-on-LAN function, MAC address of management port is needed. For the information of MAC address, please refer to the chapter 6.2, [Management Port Settings](#) page.

- **Enable Wake-on-SAS:** Check to enable the wake-on-SAS feature. If the wake-on-SAS feature is enabled and the expansion units (XD5300 series) are connected to the proprietary wake-on-SAS cables, the expansion units will power on or shut down together with the head unit.
-

**INFORMATION:**

For deployment of the head unit and expansion units, please refer to the chapter 4, Deployment Types and Cabling in the [XCubeSAN HardwareManual](#).



CAUTION:

Wake-on-SAS feature required QSAN proprietary expansion cables connected between the head unit and expansion units. Please contact local sales for this accessory.

When finished, click the **Apply** button to take effect.

6.3.2. Cache to Flash Status

Select the **Cache to Flash** function tab in the **Power** function submenu to show information of power module and flash module for cache to flash protection. Power module indicates BBM (Battery Backup Module) or SCM (Super Capacitor Module).



INFORMATION:

For hardware information about power module and flash module, please refer to the chapter 2.7.2, Features of the Cache-to-Flash Module section in the [XCubeSAN Hardware Manual](#).

Power Module	
Item	Information
Status	Good
Type	BBM
Power Level	100%
Temperature	+32.0(C)
Flash Module	
Item	Information
Status	Good

Figure 6-7 Cache to Flash

This table shows the column descriptions.

Table 6-1 Power Module Column Descriptions

Column Name	Description
Status	The status of power module:



	<ul style="list-style-type: none">• Good: The power module is good.• Failed: The power module is failure.• Absent: The power module is absent.• Charging: The power module is charging.
Type	The type of power module: <ul style="list-style-type: none">• BBM (Battery Backup Module)• SCM (Super Capacitor Module)
Power Level	The power level of the module.
Temperature	The temperature of the power module..

Table 6-2 Flash Module Column Descriptions

Column Name	Description
Status	The status of flash module: <ul style="list-style-type: none">• Good: The flash module is good.• Failed: The flash module is failure.• Absent: The flash module is absent.• Detecting: The flash module is detecting.

6.3.3. UPS Settings and Status

Select the **UPS** function tab in the **Power** function submenu to enable UPS (Uninterruptible Power Supply) settings and watch the UPS status.



INFORMATION:

For deployment of UPS, please refer to the chapter 3, Installing the System Hardware in the [XCubeSAN Hardware Manual](#).

UPS Status

UPS Status : On Line

UPS Battery Level : 58.00%

UPS Manufacturer : CYBERPOWER

UPS Model : PR750LCD

UPS Settings

Enable UPS Support

Communication Type : SNMP ▼

Shutdown Battery Level : 80 ▼ %

SNMP IP Address : 192.168.123.123

SNMP Version : SNMP v3 ▼

Username : snmp1 ⓘ

Use Authentication

Authentication Protocol : MD5 ▼

Authentication Password : ⓘ

Use Privacy

Privacy Protocol : DES

Privacy Password : ⓘ

Apply

Figure 6-8 UPS Status and Settings

This table shows the column descriptions.

Table 6-3 UPS Column Descriptions

Column Name	Description
UPS Status	<p>The status of UPS:</p> <ul style="list-style-type: none"> On Line: The UPS is online. On Battery: The UPS is on battery. Low Battery: The voltage of the battery is low. High Battery: The voltage of the battery is high. Replace Battery: The battery needs to be replaced. Charging: The battery is charging. Discharging: The battery is discharging. Bypass Mode: The power circuit bypasses the UPS battery, so no battery protection is available. It may happen to check if the UPS operates properly during a power loss. Or the UPS is offline for

	<p>maintenance.</p> <ul style="list-style-type: none"> • Offline: UPS is offline and is not supplying power to the load. • Overloaded: UPS is overloaded. You plugged more equipments into the UPS than it was designed to handle. • Forced Shutdown: Forced shutdown the UPS.
UPS Battery Level	The battery level of the UPS.
UPS Manufacturer	The manufacturer of the UPS.
UPS Model	The model of the UPS.

Options of UPS Settings

The options are available in this tab:

- **Enable UPS Support:** Check to enable UPS supported. Now we support network UPS via SNMP, Serial UPS with COM port, and USB UPS.
- **Communication Type:** Now we support network UPS via SNMP, Serial UPS with COM port, and USB UPS.
- **Shutdown battery Level:** If the power is shortage, the system will execute shutdown process when reaching the UPS battery level.

If Communication Type selects SNMP:

- **SNMP IP Address:** Enter the IP address of the network UPS via SNMP.
- **SNMP Version:** Select SNMP supported versions: v1, v2c, or v3. Please enter community if select SNMP v1 or v2c. If select SNMP v3, it needs more options for authentication. Please enter a username, check to use authentication if necessary, select an authentication protocol and enter an authentication password, check to use privacy if necessary, the privacy protocol supports DES, and enter a privacy password.

If Communication Type selects Serial:

- **UPS Manufacturer:** Select the UPS manufacture.
- **UPS Model:** Select the UPS model.

When finished, click the **Apply** button to take effect.

**INFORMATION:**

Authentication Protocol:

- **MD5:** The MD5 algorithm is a widely used hash function producing a 128-bit hash value. It can still be used as a checksum to verify data integrity, but only against unintentional corruption.
- **SHA:** SHA (Secure Hash Algorithm) is a cryptographic hash function which is a mathematical operation run on digital data; by comparing the computed "hash" (the output from execution of the algorithm) to a known and expected hash value, a person can determine the data's integrity.

Privacy Protocol:

- **DES:** The DES (Data Encryption Standard) is a symmetric-key algorithm for the encryption of electronic data.
-

6.4. Notification Settings

The **Notifications** function submenu provides **Email**, **Alert** and **SNMP** function tabs to show information and configuration setup.

Figure 6-9 Notifications Function Submenu

6.4.1. Email Settings

Select the **Email** function tab in the **Notifications** function submenu to be used to enter up to three email addresses for receiving the event notifications.

- **Email-to-Address:** Enter the email address for receiving the event notifications. You can also select which levels of event logs which you would like to receive. The default setting only includes **Warning** and **Error** event logs.



TIP:

Please make sure the IP address of DNS server is well-setup in **Management Port** tab. So the event notification emails can be sent successfully. Please refer to the [Management Port Settings](#) section for more details.

When finished, click the **Send Test Email & Apply** button to take effect. Or click the **Reset to Default** button to reset settings.

6.4.2. Alert Settings

Select the **Alert** function tab in the **Notifications** function submenu to be used to setup alerts via the **Syslog** protocol, the pop-up alerts and alerts on the front display. The device buzzer is also managed here.

Syslog Server Settings i	
Host Address or Name:	192.168.123.123
UDP Port:	514
Facility:	User ▼
	<input type="checkbox"/> Information <input checked="" type="checkbox"/> Warning <input checked="" type="checkbox"/> Error

Admin Interface and LCM Alerts i	
Admin Interface Popup Alerts:	<input type="checkbox"/> Information <input type="checkbox"/> Warning <input type="checkbox"/> Error
Show Alerts on LCM:	<input type="checkbox"/> Information <input checked="" type="checkbox"/> Warning <input checked="" type="checkbox"/> Error

Device Buzzer i	
Enable Buzzer:	<input checked="" type="checkbox"/>

Figure 6-11 Alert Settings

Options of Alert Settings

The options are available in this tab:

- **Syslog Server Settings:** Fill in the host address and the facility for syslog service. The default UDP port is 514. You can also check the alert levels here. Most LINUX/UNIX systems built in syslog daemon.
- **Admin Interface and LCM Alerts:** You can check or uncheck the alert levels which you would like to have pop-up message in the Web UI and show on LCM.
- **Device Buzzer:** Check it to enable the device buzzer. Uncheck it to disable device buzzer.

When finished, click the **Apply** button to tack effect.



INFORMATION:

The device buzzer features are listed below:

- The buzzer alarms 1 second when system boots up successfully.
 - The buzzer alarms continuously when there is error occurred. The alarm will be stopped after error resolved or be muted.
 - The alarm will be muted automatically when the error is resolved. For example, when a RAID 5 pool is degraded and alarm rings immediately, user replaces one disk drive for rebuild. When the rebuild process is done, the alarm will be muted automatically.
-

6.4.3. SNMP Settings

Select the **SNMP** function tab in the **Notifications** function submenu to be used to setup SNMP (Simple Network Management Protocol) traps for alerting with event logs and also setup SNMP server settings for client monitoring.

SNMP Trap
 Enable SNMP (Simple Network Management Protocol) trap to send system event logs to SNMP trap agent.

Enable SNMP Trap

SNMP Trap Port: (Default Port : 162)

Information Warning Error

SNMP Trap Address 1:

SNMP Trap Address 2:

SNMP Trap Address 3:

SNMP Server

SNMP Version:

Username: ⓘ

Authentication Protocol:

Authentication Password: ⓘ

Use Privacy

Privacy Protocol:

Privacy Password: ⓘ

SNMP MIB Files

Download SNMP MIB File:

Download iSCSI MIB File:

Figure 6-12 SNMP Settings

Options of SNMP Trap Settings

The options are available in this tab:

- **Enable SNMP Trap:** Check to enable SNMP trap to send system event logs to SNMP trap agent. The default SNMP trap port is 162. You can check or uncheck the alert levels which you would like to receive. And then fill in up to three SNMP trap addresses for receiving the event notifications.

Options of SNMP Server Settings

The options are available on this tab:

- **SNMP Version:** Select SNMP supported versions: v1/ v2, or v3. If select SNMP v3, it needs more options for authentication. Please enter a username, select an

authentication protocol and enter an authentication password, check to use privacy if necessary, select a privacy protocol, and enter a privacy password.

When finished, click the **Apply** button to take effect.



INFORMATION:

Authentication Protocol:

- **MD5:** The MD5 algorithm is a widely used hash function producing a 128-bit hash value. It can still be used as a checksum to verify data integrity, but only against unintentional corruption.
- **SHA:** SHA (Secure Hash Algorithm) is a cryptographic hash function which is a mathematical operation run on digital data; by comparing the computed "hash" (the output from execution of the algorithm) to a known and expected hash value, a person can determine the data's integrity.

Privacy Protocol:

- **DES:** The DES (Data Encryption Standard) is a symmetric-key algorithm for the encryption of electronic data.
- **AES:** The AES (Advanced Encryption Standard) is a specification for the encryption of electronic data. It supersedes the DES.

Options of SNMP MIB Files

The options are available in this tab:

- **Download SNMP MIB File:** Click the **Download** button to save the SNMP MIB file which can be imported to the SNMP client tool to get system information. You can view fan, voltage, and system status via SNMP MIB.
- **Download iSCSI MIB File:** Click the **Download** button to save the iSCSI MIB file which can be imported to the SNMP client tool to get network information. You can view iSCSI traffic via iSCSI MIB.

6.5. Maintenance

The **Maintenance** function submenu provides **System Information, Upgrade, Firmware Synchronization** (This option is only visible when dual controllers is installed.), **System**

Identification, Reset to Defaults, Configuration Backup, Volume Restoration, and Reboot / Shutdown function tabs. The **Volume Restoration** function will be described in the [Volume Restoration](#) section in the Advanced Volume Administration chapter, the others are described in the following sections.

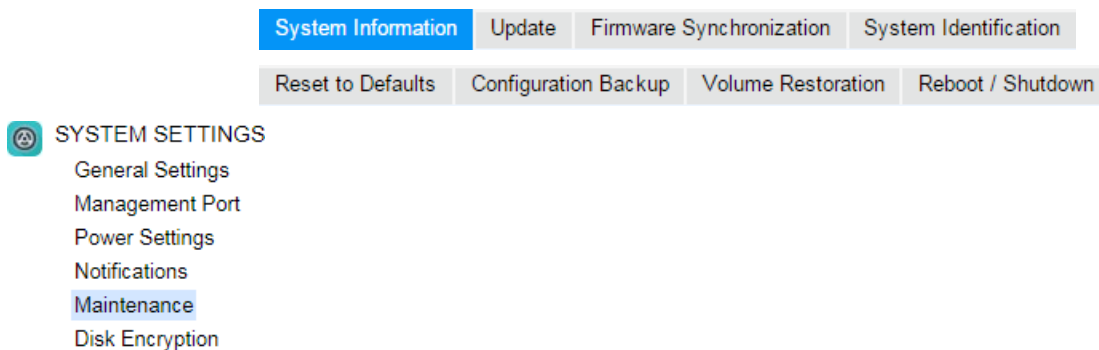

Figure 6-13 Maintenance Function Submenu

6.5.1. System Information

Select the **System Information** function tab in the **Maintenance** function submenu to display all system information.

System	
Item	Information
System Name	XS5216-D40000
Model Name	XS5216
System Serial Number	QW3160160I0021001
System Controller Status	Dual Controller, Active-Active
Master Controller	Controller 1
Controller 1	
Item	Information
Controller Serial Number	50013780080A0440
CPU	Intel(R) Xeon(R) Processor D-1500 4 Cores
Memory	8 GB
Host Card Slot 1	Empty
Host Card Slot 2	Empty
Firmware Version	1.2.0
SAS IOC Firmware Version	07.00.01.00
SAS Expander Firmware Version	1000

Controller 2	
Item	Information
Intel(R) Xeon(R) Processor D-1500 4 Cores	CPU
8 GB	Memory
Empty	Host Card Slot 1
Empty	Host Card Slot 2
1.2.0	Firmware Version
07.00.01.00	SAS IOC Firmware Version
1000	SAS Expander Firmware Vers
Backplane	
Information	Item
001378D40000	Backplane Serial Number
QW316	Backplane ID
1.2.0	MCU Version
Licenses	
Information	Item
Enabled	SSD Cache
Enabled	Auto Tiering
<input type="button" value="Download Service Package"/>	

Figure 6-14 System Information

This table shows the descriptions.

Table 6-4 Status in System Information Column Descriptions

Column Name	Description
System Availability Status	<p>The status of system availability:</p> <ul style="list-style-type: none"> Dual Controller, Active/Active: Dual controllers and expansion units are in normal stage. Dual Controller, Degraded: In dual controller mode, one controller or one of expansion unit fails or they have been plugged out. Please replace or insert a good controller. Dual Controller, Lockdown: In dual controller mode, the configurations of two controllers are different, including the memory capacity, host cards, and controller firmware version. Please check the hardware configurations of two controllers or execute firmware synchronization. Single Controller: Single controller mode.

Options of System Information

The options are available in this tab:

- **Download Service Package:** Click button to download system information for service.



CAUTION:

If you try to increase the system memory and running in dual controller mode, please make sure both controllers have the same DIMM on each corresponding memory slot. Failing to do so will result in controller malfunction, which will not be covered by warranty.

6.5.2. Firmware Update

Select the **Update** function tab in the **Maintenance** function submenu to be used to update controller firmware, expansion unit firmware, change operation mode, and active licenses.



TIP:

Before upgrading, we recommend you to export your system configurations first in the **Configuration Backup** function tab. Please refer to the [Configuration Backup](#) section for more details.

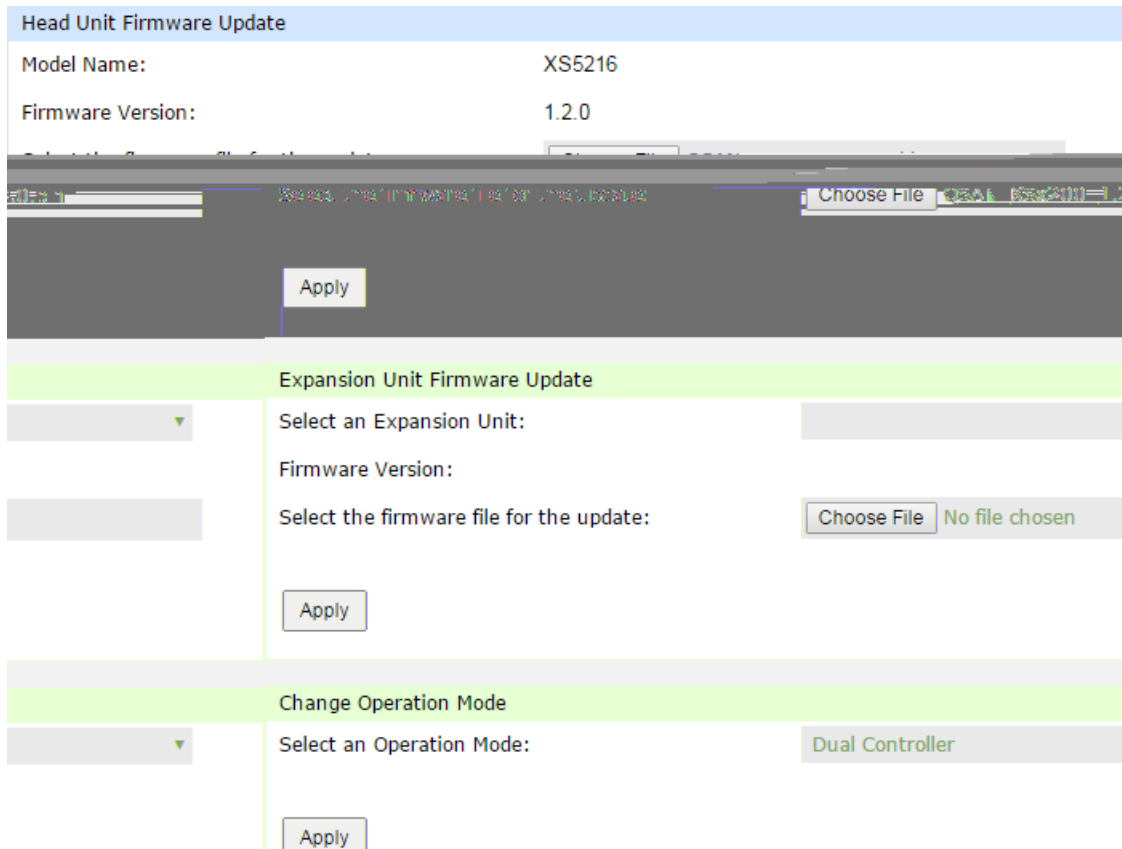

Figure 6-15 Firmware Update

Options of Firmware Update

The options are available in this tab:

- Head Unit Firmware Update:** Please prepare new controller firmware file named “xxxx.bin” in local hard drive, click the **Choose File** button to select the firmware file. Then click the **Apply** button, it will pop up a warning message, click the **OK** button to start upgrading the firmware.

When upgrading, there is a progress bar running. After finished upgrading, the system must reboot manually to make the new firmware take effect.



TIP:

Firmware update can be done without downtime if the MPIO configuration is well-configured between the connected host / server and both controllers. A firmware update process will update both controllers at the same time. After finished updating, you have to reboot the system.

A system reboot will reboot the master controller first. At this point, the slave controller will take over all tasks (and becomes a new master controller). After the original master controller finishes the booting process (the original master controller is slave controller at this moment), the new master controller (the original slave controller) will reboot automatically, and so on for the original master controller to take over the tasks, once the original slave controller finishes the booting process, the firmware update procedure is completed.

- **Expansion Unit Firmware Update:** To upgrade expansion unit firmware, first select an expansion unit. Then other steps are the same as the head unit firmware update. After finished upgrading, the expansion unit must reboot manually to make the new firmware take effect.
- **Change the Operation Mode:** This option can be modified to operate in dual-controller or single-controller mode here. If the system installed only one controller, switch this mode to **Single Controller**, and then click the **Apply** button. After changing the operation mode, the system must reboot manually to take effect.

SSD Cache License

Download Request License file and send to your local sales to get a License Key.

Select the license file to enable SSD Cache: Choose File No file chosen

Apply
Request License

Auto Tiering License

Download Request License file and send to your local sales to get a License Key.

Select the license file to enable Auto Tiering: Choose File No file chosen

Apply
Request License

Figure 6-16 Enable Licenses

- **SSD Cache License:** This option enables SSD cache. Download the **Request License** file and send to your local sales to obtain a License Key. After getting the license key, click the **Choose File** button to select it, and then click the **Apply** button to enable. Each license key is unique and dedicated to a specific system. If you have already enabled, this option will be invisible. After enabling the license, the system must reboot manually to take effect.
- **Auto Tiering License:** This option enables auto tiering. The operation is the same as SSD cache.

CAUTION:

After enabling the licenses, the functions cannot be disabled and these license options will be hidden.

Figure 6-17



CAUTION:

DO NOT recommend using trial features in official production.

After the trial license expires for SSD cache, all SSD cache pools are deleted. Read-write SSD cache pool will be flushed first.

After the trial license expires for auto tiering, all auto tiering pools are deactivated.



INFORMATION:

Trial license feature is available in SANOS firmware 1.4.0.

6.5.3. Firmware Synchronization

Select the **Firmware Synchronization** function tab in the **Maintenance** function submenu to be used on dual controller systems to synchronize the controller firmware versions when the firmware of the master controller and the slave controller are different. The firmware of slave controller is always changed to match the firmware of the master controller. It doesn't matter if the firmware version of slave controller is newer or older than that of the master. Normally, the firmware versions in both controllers are the same.

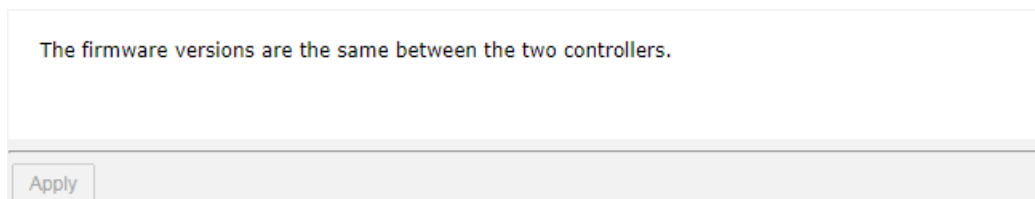

Figure 6-18 Both Firmware Versions are Synchronized

If the firmware versions between two controllers are different, it will display a warning message. Click the **Apply** button to synchronize and force a reboot.



INFORMATION:

This tab is only visible when the dual controllers are installed. A single controller system does not have this option.

6.5.4. System Identification

Select the **System Identification** function tab in the **Maintenance** function submenu to turn on or turn off the UID (Unique Identifier) LED control mechanism. The system UID LED helps users to easily identify the system location within the rack.

When the UID LEDs are turn off, click the **OK** button to turn on the UID LEDs which are light blue color, located on the right panel of front view and both controllers of rear view.

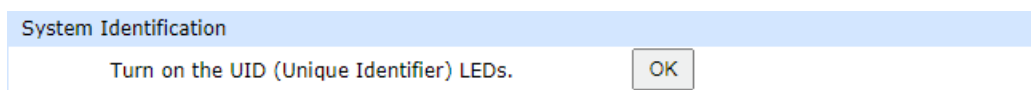

Figure 6-19 Turn on the UID (Unique Identifier) LED

When the UID LEDs are steady on, click the **OK** button to turn off the UID LEDs.



INFORMATION:

For the front and rear view about the UID LEDs, please refer to chapter 2, System Components Overview in the [XCubeSAN Hardware Manual](#).

6.5.5. Reset to Factory Defaults

Select the **Reset to Defaults** function tab in the **Maintenance** function submenu to allow users to reset the system configurations back to the factory default settings and clean all configurations of the expansion enclosure ID.

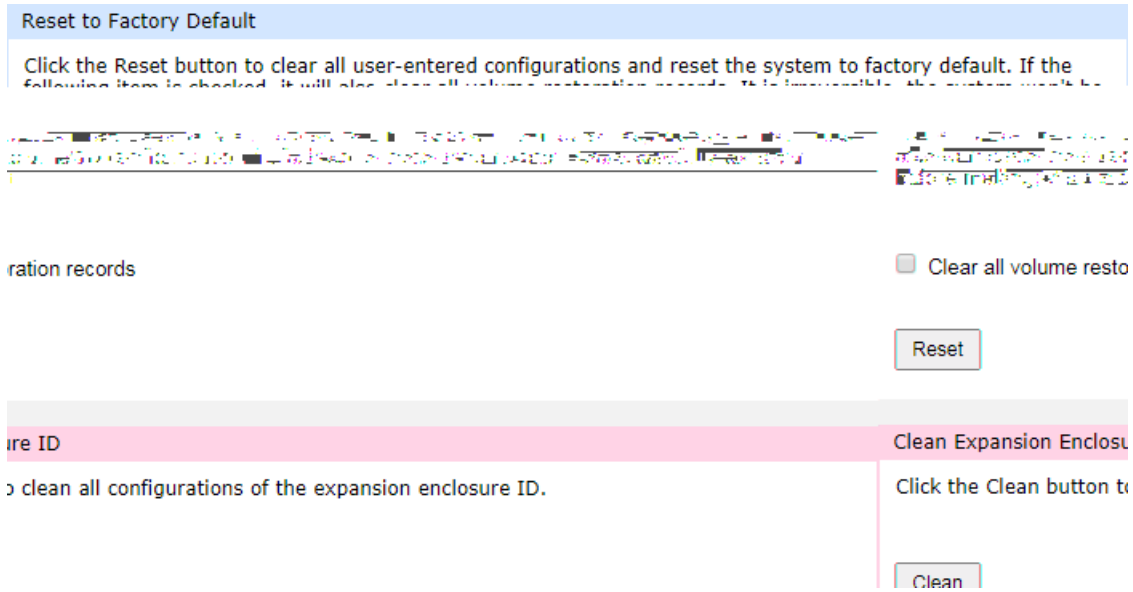

Figure 6-20 Reset to Defaults

Options of Resets to Factory Defaults

The options are available in this tab:

- Reset to Defaults:** Click the **Reset** button to progress reset to defaults and force a reboot. The default settings are:
 - Reset **Management Port** IP address to DHCP, and then fix IP address: 169.254.1.234/16.
 - Reset admin's **Password** to 1234.
 - Reset **System Name** to model name plus the last 6 digits of serial number. For example: XS5216-123456.
 - Reset IP addresses of all **iSCSI Ports** to 192.168.1.1, 192.168.2.1, ... etc.
 - Reset link speed of all **Fibre Channel Ports** to Automatic.
 - Clear all access control settings of the host connectivity.
- Clear all volume restoration records:** Check to clear all volume restoration records.



CAUTION:

Process the **Reset to Defaults** function will force a reboot. To clear all volume restoration records is irreversible. The system won't be able to restore the recorded RAID configuration if it fails while there is no record. Please carefully consider before making this reset.

- **Clean Expansion Enclosure ID:** Click the **Clean** button to clean all configurations of expansion enclosure ID. A clean will cause the system shutdown, and then you have to start manually.



INFORMATION:

The XCubeDAS XD5300 series features the seven-segment LED display for users to easily identify a specific XCubeDAS system. The enclosure ID is assigned by head unit (XCubeSAN series) automatically. The seven-segment LED display supports up to ten XCubeDAS systems, and the numbering rule will start from 1 to A. For dual controller models, both controllers will display the same enclosure ID. After the XD5300 had been assigned the enclosure ID, head unit will assign the same enclosure ID when the system reboots or goes shutdown. For hardware information enclosure ID, please refer to the chapter 2.7, Seven-segment LED Display section in the [XCubeDAS Hardware Manual](#).



CAUTION:

Process the **Clean Expansion Enclosure ID** function will force the system shutdown to clean all configurations of expansion enclosure ID.

6.5.6. Configuration Backup

Select the **Configuration Backup** function tab in the **Maintenance** function submenu to be used to either save system configuration (export) or apply a saved configuration (import).

Export

Export Mode: System ▼

Export File: CONFIG-XS5216-D40000-20170627-135559.csv

Apply

Import

Import File: Choose File No file chosen

Apply

Figure 6-21 Configuration Backup

While the volume configuration settings are available for exporting, to prevent conflicts and overwriting existing data, they cannot be imported.

Options of Configuration Backup

The options are available in this tab:

- **Export:** Select the **Export Mode** for exporting system or volume configurations, then click the **Export** button to save a file.
- **Import:** Import all system configurations excluding volume configuration.



CAUTION:

The Import option will import all system configurations excluding volume configuration. The current system configurations will be replaced.

6.5.7. Reboot and Shutdown

Select the **Reboot / Shutdown** tab in the **Maintenance** function submenu to be used to reboot or shutdown the system. Before powering off the system, it is highly recommended to execute **Shutdown** function to flush all data from memory cache into the disk drives. The step is important for data protection.



Figure 6-22 Reboot and Shutdown

The **Reboot** function has three options; reboot both controllers, controller 1 only or controller 2 only.

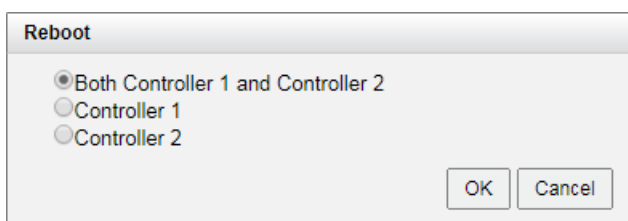

Figure 6-23 Reboot Options

6.6. Disk Encryption

The **Disk Encryption** function submenu provides **Authentication**, and **SEDs** function tabs. SED (Self-Encrypting Drive) support will be described in the chapter 14, [SED and ISE Support](#) chapter.

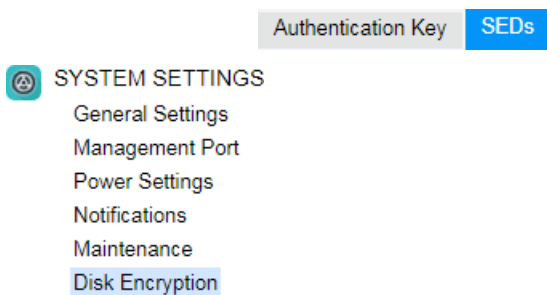

Figure 6-24 Disk Encryption Function Submenu

7. Host Configuration

This chapter describes host protocol concepts and the details of host configuration. The **HOST CONFIGURATION** function menu provides submenus of **Overview**, **iSCSI Ports**, and **Fibre Channel Ports**.



INFORMATION:

The **Fibre Channel Ports** function menu will appear only when the system has a fibre channel host card installed.

7.1. Host Protocol Technology

This section describes the host protocol technology of iSCSI (Internet SCSI) and fibre channel.

7.1.1. iSCSI Technology

iSCSI (Internet SCSI) is a protocol which encapsulates SCSI (Small Computer System Interface) commands and data in TCP/IP packets for linking storage devices with servers over common IP infrastructures. iSCSI provides high performance SANs over standard IP networks like LAN, WAN or the Internet.

IP SANs are true SANs (Storage Area Networks) which allow several servers to attach to an infinite number of storage volumes by using iSCSI over TCP/IP networks. IP SANs can scale the storage capacity with any type and brand of storage system. In addition, it can be used by any type of network (Ethernet, Fast Ethernet, Gigabit Ethernet, and 10 Gigabit Ethernet) and combination of operating systems (Microsoft Windows, Linux, Solaris, Mac, etc.) within the SAN network. IP-SANs also include mechanisms for security, data replication, multi-path and high availability.

Storage protocols, such as iSCSI, have “two ends” in the connection. These ends are initiator and target. In iSCSI, we call them iSCSI initiator and iSCSI target. The iSCSI initiator requests or initiates any iSCSI communication. It requests all SCSI operations like read or write. An initiator is usually located on the host side (either an iSCSI HBA or iSCSI SW initiator).

The target is the storage device itself or an appliance which controls and serves volumes. The target is the device which performs SCSI command or bridge to an attached storage device.

Each iSCSI node, that is, an initiator or target, has a unique IQN (iSCSI Qualified Name). The IQN is formed according to the rules that were adopted for Internet nodes. The IQNs can be abbreviated by using a descriptive name, which is known as an alias. An alias can be assigned to an initiator or a target.

Table 7-1 iSCSI Parameters

Item	Value
Maximum iSCSI target quantity per system	256
Maximum initiator address quantity per system	256
Maximum host quantity for single controller system	512
Maximum host quantity for dual controller system	1,024
Maximum iSCSI session quantity for single controller	1,024
Maximum iSCSI session quantity for dual controller	2,048
Maximum iSCSI connection quantity for single controller	4,096
Maximum iSCSI connection quantity for dual controller	8,192
Maximum CHAP accounts per system	64

7.1.2. Fibre Channel Technology

Fibre channel is an extremely fast system interface. It was initially developed for use primarily in the supercomputing field, but has become the standard connection type for SAN in enterprise storage.

The target is the storage device itself or an appliance which controls and serves volumes or virtual volumes. The target is the device which performs SCSI commands or bridges to an attached storage device.

Fibre Channel is the traditional method used for data center storage connectivity. The XCubeSAN supports fibre channel connectivity at speeds of 4, 8, and 16 Gbps. Fibre Channel Protocol is used to encapsulate SCSI commands over the fibre channel network. Each device on the network has a unique 64 bit WWPN (World Wide Port Name).

Table 7-2 Fibre Channel Parameters

Item	Value
Maximum host quantity for single controller	256
Maximum host quantity for dual controller	512

7.2. Host Connectivity Overview

Storage system provides different type of host connectivity according to the system configuration, it could be base system or host cards installed system. The host cards must be installed the same type on both controllers. Currently host card has several types, 1GbE iSCSI (RJ45), 10GbE iSCSI (SFP+), 25GbE iSCSI (SFP28), 16Gb FC (SFP+), and 32Gb FC (SFP28) for selection according to system infrastructure.

Select **Overview** function submenu to display all host connectivity in system. The status and information of all host ports are listed.



Figure 7-1 Overview Function Submenu

The following is an example to show all host connectivity in system.

Controller 1			
Location	Name	Status	MAC Address/WWPN
Onboard	LAN1 (10Gb)	Down	00:13:78:ff:88:02
Onboard	LAN2 (10Gb)	Down	00:13:78:ff:88:03
Slot2	LAN1 (1Gb)	1 Gb/s	00:13:78:ff:88:04
Slot2	LAN2 (1Gb)	1 Gb/s	00:13:78:ff:88:05
Slot2	LAN3 (1Gb)	1 Gb/s	00:13:78:ff:88:06
Slot2	LAN4 (1Gb)	1 Gb/s	00:13:78:ff:88:07
Slot1	FC1 (16Gb)	16Gb/s	2100001378FF8800
Slot1	FC2 (16Gb)	16Gb/s	2200001378FF8800
Slot1	FC3 (16Gb)	16Gb/s	2300001378FF8800
Slot1	FC4 (16Gb)	16Gb/s	2400001378FF8800

Controller 2			
Location	Name	Status	MAC Address/WWPN
Onboard	LAN1 (10Gb)	Down	00:13:78:ff:88:02
Down	00:13:78:ff:88:0d	Onboard	LAN2 (10Gb)
3Gb/s	00:13:78:ff:88:0e	Slot2	LAN1 (1Gb)
3Gb/s	00:13:78:ff:88:0f	Slot2	LAN2 (1Gb)
3Gb/s	00:13:78:ff:88:10	Slot2	LAN3 (1Gb)
3Gb/s	00:13:78:ff:88:11	Slot2	LAN4 (1Gb)
Gb/s	2900001378FF8800	Slot1	FC1 (16Gb)
Gb/s	2A00001378FF8800	Slot1	FC2 (16Gb)
Gb/s	2B00001378FF8800	Slot1	FC3 (16Gb)
Gb/s	2C00001378FF8800	Slot1	FC4 (16Gb)

Figure 7-2 Host Port Overview

The columns display information of **Location**, **Name**, **Status**, and **MAC address** for iSCSI or **WWPN** (World Wide Port Name) for fibre channel.

**INFORMATION:**

Fibre Channel / iSCSI Host Card at Slot 1:

- RHCF32P2, 2 x 32Gb FC (SFP28) ports
- HQ-16F4S2: 4 x 16Gb FC (SFP+) ports
- HQ-16F2S2: 2 x 16Gb FC (SFP+) ports
- RHCE25P2, 2 x 25GbE iSCSI (SFP28) ports
- HQ-10G4S2: 4 x 10GbE iSCSI (SFP+) ports
- HQ-10G2T: 2 x 10GBASE-T iSCSI (RJ45) ports
- HQ-01G4T: 4 x 1GBASE-T iSCSI (RJ45) ports

iSCSI Host Card at Slot 2 (20Gb bandwidth):

- RHCF32P2, 2 x 32Gb FC (SFP28) ports
 - HQ-16F4S2: 4 x 16Gb FC (SFP+) ports
 - HQ-16F2S2: 2 x 16Gb FC (SFP+) ports
 - RHCE25P2, 2 x 25GbE iSCSI (SFP28) ports
 - HQ-10G4S2, 4 x 10GbE iSCSI (SFP+) ports
 - HQ-10G2T: 2 x 10GBASE-T iSCSI (RJ45) ports
 - HQ-01G4T, 4 x 1GBASE-T iSCSI (RJ45) ports
-

**INFORMATION:**

For hardware information about host cards, please refer to the chapter 3.3, Installing the Optional Host Cards section in the [XCubeSAN Hardware Manual](#).

**CAUTION:**

If you change the configuration of the host cards including insert or remove them, it has to execute **Reset to Defaults** function in **SYSTEM SETTINGS -> Maintenance -> Reset to Defaults**. Before that, you can keep the system configurations by export and import the configuration file in **SYSTEM SETTINGS -> Maintenance -> Configuration Backup**. Please refer to the chapter 6.5.5, [Reset to Factory Default](#) section and the chapter 6.5.5, [Configuration Backup](#) section for more details.

7.3. Configure iSCSI Connectivity

The **iSCSI Ports** provides **iSCSI Ports**, **iSCSI Settings**, **iSCSI Targets**, **CHAP Accounts**, and **Sessions** function tabs to configure iSCSI ports.

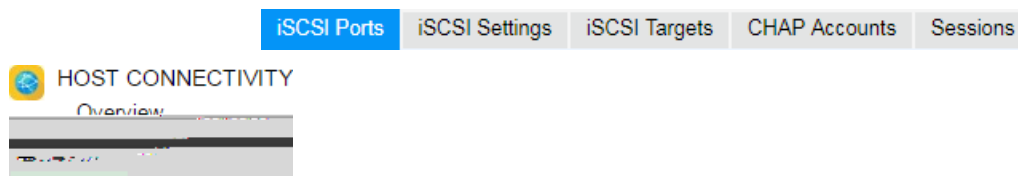

Figure 7-3 iSCSI Ports Function Submenu

7.3.1. Configure iSCSI Ports

Select the **iSCSI Ports** function submenu to show information of iSCSI ports where they are located (onboard or host cards). The iSCSI port properties can be configured by clicking the functions button ▼ to the left side of the specific iSCSI port.

Controller 1									
	Location	Name	Status	LAG	VLAN ID	IP Address	Gateway	Jumbo Frame	MAC Address
▼	Onboard	LAN1 (10Gb)	Down	N/A	N/A	192.168.1.1	192.168.1.254	Disabled	00:13:78:ff:88:02
▼	Onboard	LAN2 (10Gb)	Down	N/A	N/A	192.168.2.1	192.168.2.254	Disabled	00:13:78:ff:88:03
▼	Slot2	LAN1 (1Gb)	1 Gb/s	N/A	N/A	192.168.100.11		Disabled	00:13:78:ff:88:04
▼	Slot2	LAN2 (1Gb)	1 Gb/s	N/A	N/A	192.168.100.12		Disabled	00:13:78:ff:88:05
▼	Slot2	LAN3 (1Gb)	1 Gb/s	N/A	N/A	192.168.100.13		Disabled	00:13:78:ff:88:06
▼	Slot2	LAN4 (1Gb)	1 Gb/s	N/A	N/A	192.168.100.14		Disabled	00:13:78:ff:88:07

Controller 2										
	Location	Name	Status	LAG	VLAN ID	IP Address	Gateway	Jumbo Frame	MAC Address	
▼	N/A	N/A	192.168.12.1	192.168.12.254	Disabled	00:13:78:ff:88:0d	▼	Onboard	LAN2 (10Gb)	Down
▼	N/A	N/A	192.168.100.21		Disabled	00:13:78:ff:88:0e	▼	Slot2	LAN1 (1Gb)	1 Gb/s
▼	N/A	N/A	192.168.100.22		Disabled	00:13:78:ff:88:0f	▼	Slot2	LAN2 (1Gb)	1 Gb/s
▼	N/A	N/A	192.168.100.23		Disabled	00:13:78:ff:88:10	▼	Slot2	LAN3 (1Gb)	1 Gb/s
▼	N/A	N/A	192.168.100.24		Disabled	00:13:78:ff:88:11	▼	Slot2	LAN4 (1Gb)	1 Gb/s

Figure 7-4 List iSCSI Ports

The columns display information of **Location**, **Name**, **Status**, **LAG** (Link Aggregation), **VLAN ID** (Virtual LAN ID), **IP address**, **Gateway** IP address, **Jumbo Frame** status, and **MAC address**.

Set IP Address

Click ▼ -> **Set IP Address** which can assign an iSCSI IP address of the iSCSI data port.

There are two options: Use DHCP to acquire an IP address automatically or specify a Static IP Address to set the IP address manually.



INFORMATION:

DHCP: The Dynamic Host Configuration Protocol is a standardized network protocol used on IP (Internet Protocol) networks for dynamically distributing network configuration parameters, such as IP addresses for interfaces and services. With DHCP, computers request IP addresses and networking parameters automatically from a DHCP server, reducing the need for a network administrator or a user to configure these settings manually.

Figure 7-5 iSCSI IP Address Settings

Set Link Aggregation

Click ▼ -> **Set Link Aggregation**, the default mode of each iSCSI data port is connected without any bonding. Two bonding methods, Trunking and LACP (Link Aggregation Control Protocol), can be selected. At least two iSCSI data ports must be checked for iSCSI link aggregation.

Set Link Aggregation

Select the network interfaces that you would like to bond together.

Bonding Method: Trunking LACP i

IP Address: 192.168.1.1

Subnet Mask: 255.255.255.0

Gateway: 192.168.1.254

Network Setup: Onboard-LAN1 (10Gb)
 Onboard-LAN2 (10Gb)

Figure 7-6 Set Link Aggregation



INFORMATION:

Trunking: Sometimes called “Port Trunking” configures multiple iSCSI ports to be grouped together into one in order to increase the connection speed beyond the limit of a single iSCSI port.

LACP: The Link Aggregation Control Protocol is part of IEEE 802.3ad that allows bonding several physical ports together to form a single logical channel. LACP allows a network switch to negotiate an automatic bundle by sending LACP packets to the peer. LACP can increase bandwidth usage and automatically perform failover when the link status fails on a port.

Set VLAN ID

Click ▼ -> **Set VLAN ID**, VLAN (Virtual LAN) is a logical grouping mechanism implemented on switch device. VLANs are collections of switching ports that comprise a single broadcast domain. It allows network traffic to transfer more efficiently within these logical subgroups. Please consult your network switch user manual for VLAN setting instructions. Most of the work is done at the switch. Please make sure that your VLAN ID of iSCSI port matches that of switch port. If your network environment supports VLAN, you can use this function to change the configurations. Fill in VLAN ID and Priority settings to enable VLAN.

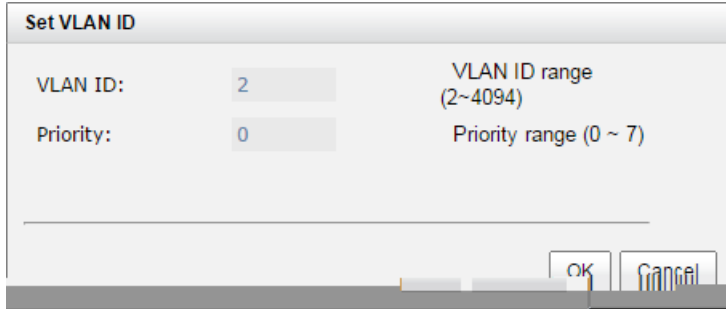

Figure 7-7 Set VLAN ID



INFORMATION:

VLAN ID: VLAN ID is a number ranges from 2 to 4094. Three numbers (0, 1, and 4095) are reserved for special purposes.

Priority: The PCP (Priority Code Point) is a number ranges from 0 to 7 and reserved for QoS (Quality of Service). The definition is compliant with IEEE 802.1p protocol and 0 is the default value. In normal cases, you don't need to set this value.

Set Default Gateway

Click ▼ -> **Set Default Gateway** to set the gateway of the IP address as default gateway. There can be only one default gateway.

Remove Default Gateway

To remove the default gateway, click ▼ -> **Remove Default Gateway**.

Set Jumbo Frames

Click ▼ -> **Set Jumbo Frames** to set the MTU (Maximum Transmission Unit) size. The jumbo frame size could be set as 4000 or 9000 bytes. Jumbo Frame is disabled by default.

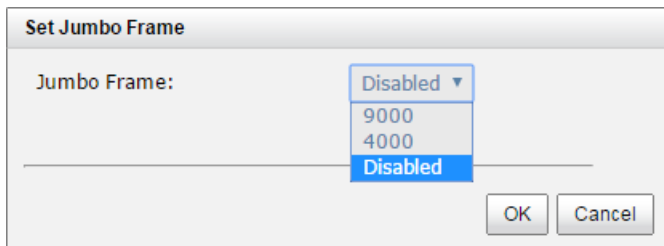

Figure 7-8 Set Jumbo Frame



CAUTION:

If the VLAN ID or jumbo frames are set, the related switching hub and HBA on host must be set, too. Otherwise, the LAN connection cannot work properly.

Ping Host

Click ▼ -> **Ping Host**, it can verify the port connection from a target to the corresponding host data port. Input the host's IP address and click **Start** button. The system will display the ping result. Click **Stop** button will stop ping activity.

Please input the host's IP address:

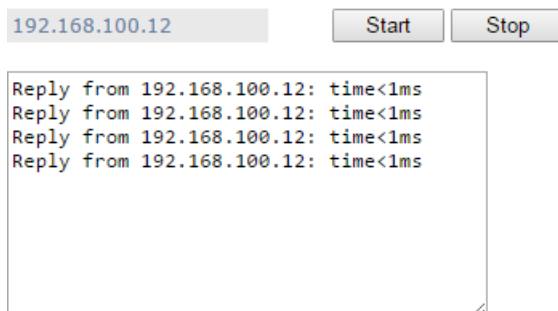

Figure 7-9 Ping Host

Reset Port

Click ▼ -> **Reset Port**, which is generally used to recover from a port malfunction.

7.3.2. Configure iSCSI Settings

Select the **iSCSI Settings** function tab in the **iSCSI Ports** function submenu to provide to setup entity name of the system and iSNS (Internet Storage Name Service) server. The entity name is default in IQN (iSCSI Qualified Name) format and could be modified for management purpose. The iSNS IP is used by iSNS protocol for automated discovery, management and configuration of iSCSI devices on a TCP/IP network. To use iSNS, an iSNS server must be added to the SAN. The iSNS server IP address must be added to the storage system for iSCSI initiator service to send queries.

Entity Name

Entity Name: 

The entity name is for a device or gateway that is accessible from the network.

iSNS IP Address

iSNS IP Address:

The iSNS protocol allows automated discovery, management, and configuration of iSCSI devices on a network.

Figure 7-10 Entity Name and iSNS Settings

Options of iSCSI Settings

The options are available in this tab:

- **Entity Name:** Change the entity name; highlight the old name and type in a new one. The maximum length of entity name is 200 characters. Valid characters are [a~z | 0~9 | - . :].
- **iSNS IP Address:** The option can change iSNS IP address for internet storage name service.

When finished, click the **Apply** button to effect changes.



INFORMATION:

iSNS: The iSNS protocol allows automated discovery, management, and configuration of iSCSI devices on a network.

7.3.3. Configure iSCSI Targets

Select the **iSCSI Targets** function tab in the **iSCSI Ports** function submenu to show the iSCSI target information for iSCSI initiator. The iSCSI target properties can be configured by clicking the functions button ▼ to the left side of the specific iSCSI target.

Controller 1

<< first < prev 1 2 3 4 5 6 7 8 9 10 next > last >>

target Name	Portal	Alias		ID	Auth	T
qn.2004-08.com.qsan:xs5216-000d40000:dev0.ctr1	10.10.1.101:3260, 10.10.1.102:3260		▼	0	CHAP	ic
qn.2004-08.com.qsan:xs5216-000d40000:dev1.ctr1	10.10.1.101:3260, 10.10.1.102:3260		▼	1	None	ic
qn.2004-08.com.qsan:xs5216-000d40000:dev2.ctr1	10.10.1.101:3260, 10.10.1.102:3260		▼	2	None	ic
qn.2004-08.com.qsan:xs5216-000d40000:dev3.ctr1	10.10.1.101:3260, 10.10.1.102:3260		▼	3	None	ic
qn.2004-08.com.qsan:xs5216-000d40000:dev4.ctr1	10.10.1.101:3260, 10.10.1.102:3260		▼	4	None	ic
qn.2004-08.com.qsan:xs5216-000d40000:dev5.ctr1	10.10.1.101:3260, 10.10.1.102:3260		▼	5	None	ic
qn.2004-08.com.qsan:xs5216-000d40000:dev6.ctr1	10.10.1.101:3260, 10.10.1.102:3260		▼	6	None	ic
qn.2004-08.com.qsan:xs5216-000d40000:dev7.ctr1	10.10.1.101:3260, 10.10.1.102:3260		▼	7	None	ic
qn.2004-08.com.qsan:xs5216-000d40000:dev8.ctr1	10.10.1.101:3260, 10.10.1.102:3260		▼	8	None	ic
qn.2004-08.com.qsan:xs5216-000d40000:dev9.ctr1	10.10.1.101:3260, 10.10.1.102:3260		▼	9	None	ic

5 6 7 8 9 10 next > last >>

<< first < prev 1 2 3 4

Figure 7-11 iSCSI Targets

Change Authentication Mode

Click ▼ -> **Authentication Method** to enable CHAP (Challenge Handshake Authentication Protocol) and mutual CHAP authentication method used in point-to-point for user login. CHAP is a type of authentication in which the authentication server sends the client a key to be used for encrypting the username and password. It enables the username and password to transmit in an encrypted form for protection.

In addition, mutual CHAP is a two-way authentication between the iSCSI target and the initiator. User has to enter another username and password which are set in the initiator side.

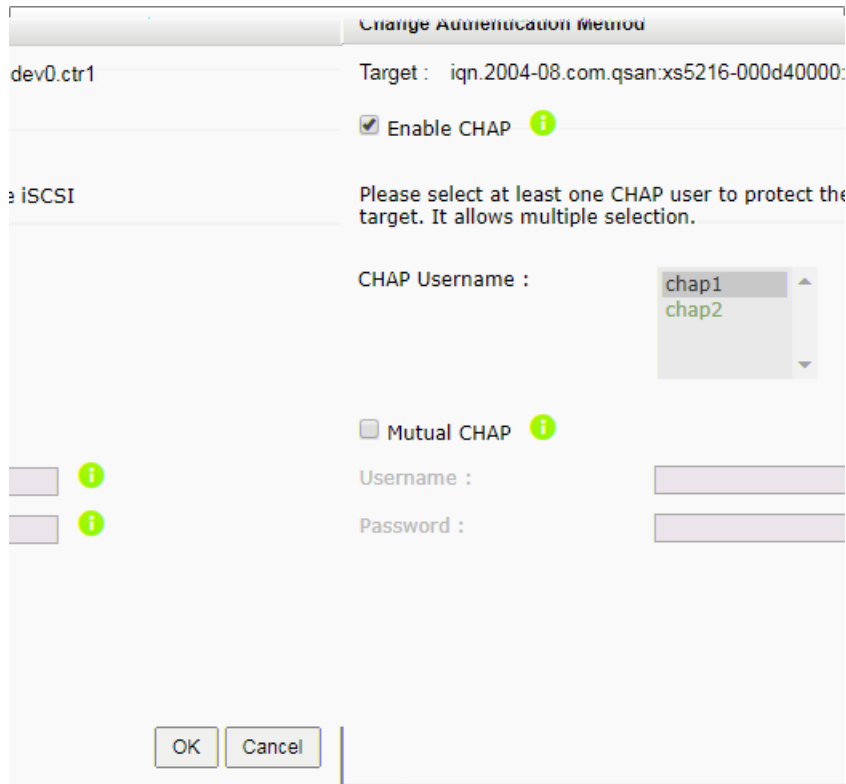

Figure 7-12 Authentication Method

Here is an example of changing the authentication method.

1. Check **Enable CHAP** to enable CHAP authentication.
2. Select the CHAP usernames that you would like to have access to this target. CHAP users can be more than one, but it must be at least one CHAP to enable on the target.
3. If necessary, check **Mutual CHAP** to enable mutual CHAP authentication.
4. Enter **Username** of mutual CHAP user. The maximum length of the username is 223 characters. Valid characters are [A~Z | a~z | 0~9 | ~!@#%^&* _-+=|(){}[];:<>.,?/].
5. Enter **Password** (mutual CHAP secret). The length of the password is between 12 to 16 characters. Valid characters are [A~Z | a~z | 0~9 | ~!@#%^&* _-+=`|\(){}[];:'<>.,?/].
6. Click the **OK** button to change the authentication method.



TIP:

A CHAP account must be added before you can use this authentication method. Please refer to the chapter 7.3.4, [Configure iSCSI CHAP Accounts](#) section to create an account.

After enabling the CHAP authentication mode, the host initiator should be set with the same CHAP account. Otherwise, the host cannot connect to the volume.

Change Target Name

Click ▼ -> **Change Target Name** to change iSCSI target name if necessary. The maximum length of the target name is 223 characters. Valid characters are [a~z | 0~9 | -.:].

Figure 7-13 Change Target Name

Change Network Portal

Click ▼ -> **Change Network Portal**, and then select the network ports that you would like to be available for this iSCSI target.

Figure 7-14 Change Network Portal

Change Alias

Click ▼ -> **Change Alias** to add or change the alias name. To remove an alias, clear out the current name. The maximum length of the alias name is 223 characters. Valid characters are [a~z | 0~9 | -.:].

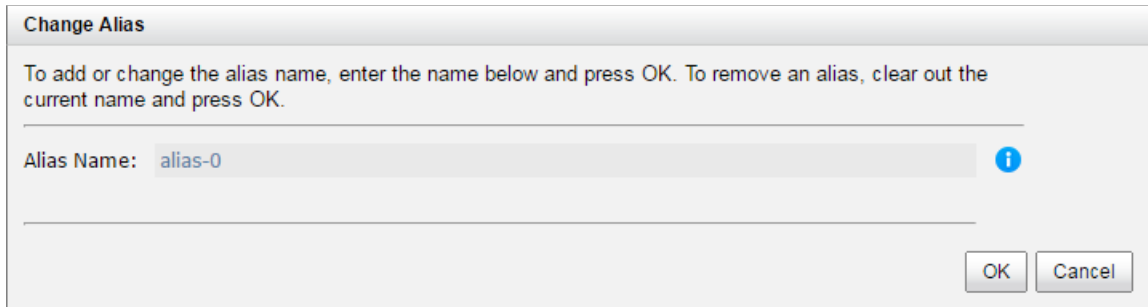

Figure 7-15 Change Alias

7.3.4. Configure iSCSI CHAP Accounts

Select the **CHAP Accounts** function tab in the **iSCSI Ports** function submenu to manage the CHAP accounts on the system.

Create a CHAP user

Here is an example of creating a CHAP user.

1. Select the **CHAP Account** function tab of the **iSCSI Ports** function submenu, click the **Create CHAP User** button.

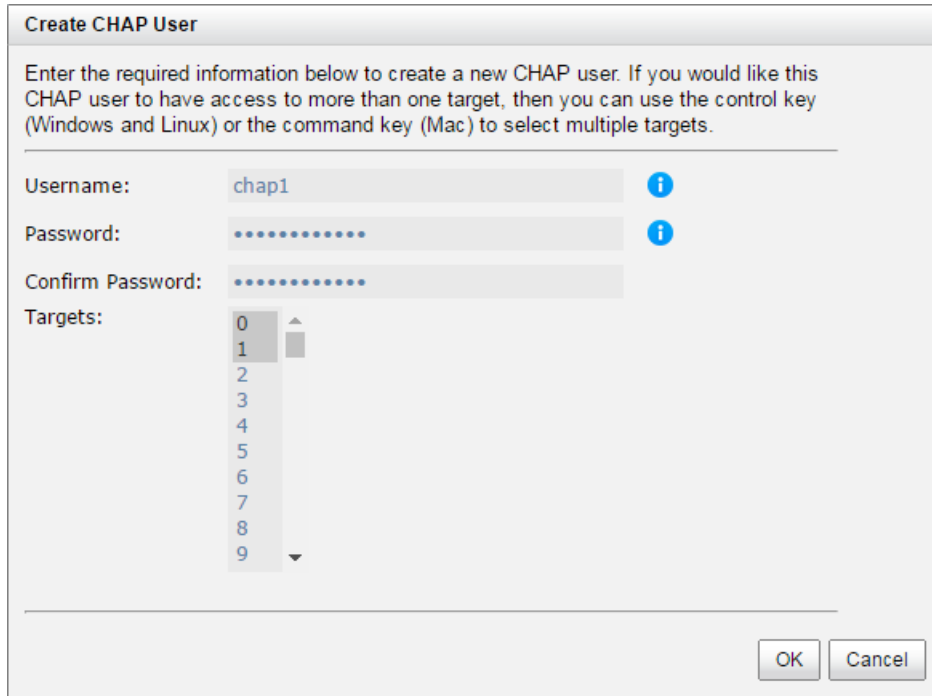

Figure 7-16 Create a CHAP User

2. Enter **Username** of CHAP user. The maximum length of the username is 223 characters. Valid characters are [A~Z | a~z | 0~9 | ~!@#%^&* _+=|(){}[];:<>./].
3. Enter **Password** (CHAP secret) and **Confirm Password**. The length of the password is between 12 to 16 characters. Valid characters are [A~Z | a~z | 0~9 | ~!@#%^&* _+=`|\(){}[];:"'<>./].
4. Select the targets using this CHAP user.
5. Click the **OK** button to create a CHAP user.

List CHAP Users

Here is an example of list CHAP users. The CHAP account properties can be configured by clicking the functions button ▼ to the left side of the CHAP account.

Figure 7-17 List CHAP Users

Modify CHAP User

Click ▼ -> **Modify CHAP User** to modify the selected CHAP user information. To change the targets that this user has access to, please go to **iSCSI Targets** tab, click on the option menu, and select **Change CHAP Users**. For more information, please refer to the chapter 7.3.3, [Configure for iSCSI Targets](#) section.

Figure 7-18 Modify a CHAP User

Here is an example of modifying the CHAP user.

6. Enter **Username** of CHAP user. The maximum length of the username is 223 characters. Valid characters are [A~Z | a~z | 0~9 | ~!@#%^&* _+=|(){}[]:;<>./].
7. Enter **Password** (CHAP secret) and **Confirm Password**. The length of the password is between 12 to 16 characters. Valid characters are [A~Z | a~z | 0~9 | ~!@#\$%^&* _+=`\|(){}[]:;'"<>.,?/].
8. Click the

7.3.5. Active Sessions

Select the **Sessions** function tab in the **iSCSI Ports** function submenu to shows all currently active iSCSI sessions and their connection information.

Controller 1					
	No.	TSIH	Initiator Name	Target Name	
▼	0	0x0008	iqn.1991-05.com.microsoft:win-hevb9u50pv9	iqn.2004-08.com.qsan:xs5224-0001246a0:dev7.ctr1	
▼	1	0x0009	iqn.1991-05.com.microsoft:win-hevb9u50pv9	iqn.2004-08.com.qsan:xs5224-0001246a0:dev8.ctr1	
▼	2	0x0006	iqn.1991-05.com.microsoft:win-hevb9u50pv9	iqn.2004-08.com.qsan:xs5224-0001246a0:dev6.ctr1	
▼	3	0x0007			

Figure 7-19 Active Sessions

This table shows the column descriptions.

Table 7-3 Active Sessions Column Descriptions

Column Name	Description
TSIH	TSIH (Target Session Identifying Handle) is used for this active session.
Initiator Name	It displays the host computer name.
Target Name	It displays the controller name.
InitialR2T	InitialR2T (Initial Ready to Transfer) is used to turn off either the use of a unidirectional R2T command or the output part of a bidirectional command. The default value is Yes.
Immed. data	Immed. data (Immediate Data) sets the support for immediate data between the initiator and the target. Both must be set to the same setting. The default value is Yes.
MaxDataOutR2T	MaxDataOutR2T (Maximum Data Outstanding Ready to Transfer) determines the maximum number of outstanding ready to transfer per task. The default value is 1.
MaxDataBurstLen	MaxDataBurstLen (Maximum Data Burst Length) determines the maximum SCSI data payload. The default value is 256kb.
DataSejinOrder	DataSejinOrder (Data Sequence in Order) determines if the PDU (Protocol Data Units) are transferred in continuously non-decreasing sequence offsets. The default value is Yes.
DataPDU InOrder	DataPDU InOrder (Data PDU in Order) determines if the data PDUs within sequences are to be in order and overlays forbidden. The

	default value is Yes.
--	-----------------------

List Connection Details

Click ▼ -> **Connection Details** which will list all connection(s) of the selected session.

Disconnect Session

Click ▼ -> **Disconnect** will disconnect the selected session, click the **OK** button to confirm.

7.4. Configure Fibre Channel Connectivity

Select the **Fibre Channel Ports** function submenu to show information of installed fibre channel ports. The fibre channel port properties can be configured by clicking the functions button ▼ to the left side of the specific fibre channel port.

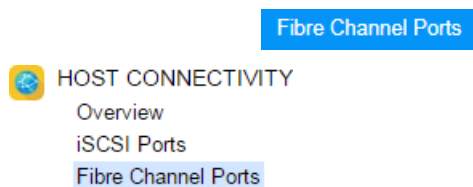

Figure 7-20 Fibre Channel Ports Function Submenu

Controller 1									
	Location	Name	Status	Change Topology	WWNN/WWPN	Loss of Signal	Loss of Sync	Link Failure	Invalid CRC
▼	Slot1	FC1 (16Gb)	16Gb/s	Point-to-Point	WWNN: 2000001378124770 WWPN: 2100001378124770	0	655	0	0
▼	Slot1	FC2 (16Gb)	Down	NA	WWNN: 2000001378124770 WWPN: 2200001378124770	0	0	0	0
▼	Slot1	FC3 (16Gb)	Down	NA	WWNN: 2000001378124770 WWPN: 2300001378124770	0	0	0	0
▼	Slot1	FC4 (16Gb)	Down	NA	WWNN: 2000001378124770 WWPN: 2400001378124770	0	0	0	0

Controller 2									
	Location	Name	Status	Change Topology	WWNN/WWPN	Loss of Signal	Loss of Sync	Link Failure	Invalid CRC
▼	Slot1	FC1 (16Gb)	16Gb/s	Point-to-Point	WWNN: 2000001378124770 WWPN: 2900001378124770	0	561	0	0
▼	Slot1	FC2 (16Gb)	Down	NA	WWNN: 2000001378124770 WWPN: 2A00001378124770	0	0	0	0
▼	Slot1	FC3 (16Gb)	Down	NA	WWNN: 2000001378124770 WWPN: 2B00001378124770	0	0	0	0
▼	Slot1	FC4 (16Gb)	Down	NA	WWNN: 2000001378124770 WWPN: 2C00001378124770	0	0	0	0

Clear All Counters

Figure 7-21 List Fibre Channel Ports

The columns display information of **Location**, **Name**, **Status**, **Topology**, **WWNN** (World Wide Node Name), **WWPN** (World Wide Port Name), and some statistical information.

7.4.1. Configure Fibre Channel Link Speed

Click ▼ -> **Change Link Speed** to change the link speed of fibre channel.

Options of Change Link Speed

The option available in this tab:

- **Link Speed:** Set the link speed of fibre channel. The options are Automatic (default), 4Gb/s to 32Gb/s. Recommend to set it as Automatic to detect the data rate automatically.

7.4.2. Configure Fibre Channel Topology

Click ▼ -> **Change Topology** to change the topology of fibre channel.

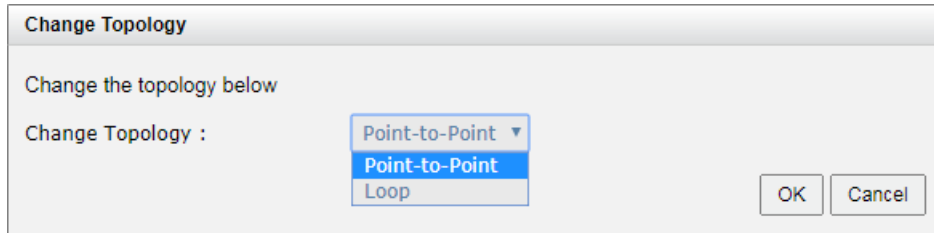

Figure 7-22 Change Topology

Options of Change Topology

The option available in this tab:

- **Topology:** Set the topology fibre channel. The option Point-to-Point is for 16Gb/s and 32Gb/s fibre channel, Point-to-Point and Loop modes are for 4Gb/s and 8Gb/s fibre channel. Set it appropriately according to your fibre channel environment.



INFORMATION:

Point-to-Point (FC-P2P): Two devices are connected directly by FC interface. This is the simplest topology with limited connectivity and supports 4Gb/s, 8Gb/s, 16Gb/s, and 32Gb/s fibre channel speed.

Loop (FC-AL, Arbitrated Loop): All devices are connection in loop or ring, similar to token ring networking. Add or remove any device will affect activities on the loop. The failure of any device will cause ring broken. Fibre Channel hub connects multiple devices together and may bypass the failed ports. A loop may also be made by cabling each port to the next in a ring. Loop mode supports 4Gb/s and 8Gb/s fibre channel speed only.



CAUTION:

If the link speed and topology are set, the related fibre channel switch and HBA on host must be set, too. Otherwise, the connection cannot work properly.

7.4.3. Configure Fibre Channel Targets

Click ▼ -> **Target Configuration** to set multi-target configurations which are accessible by the host.

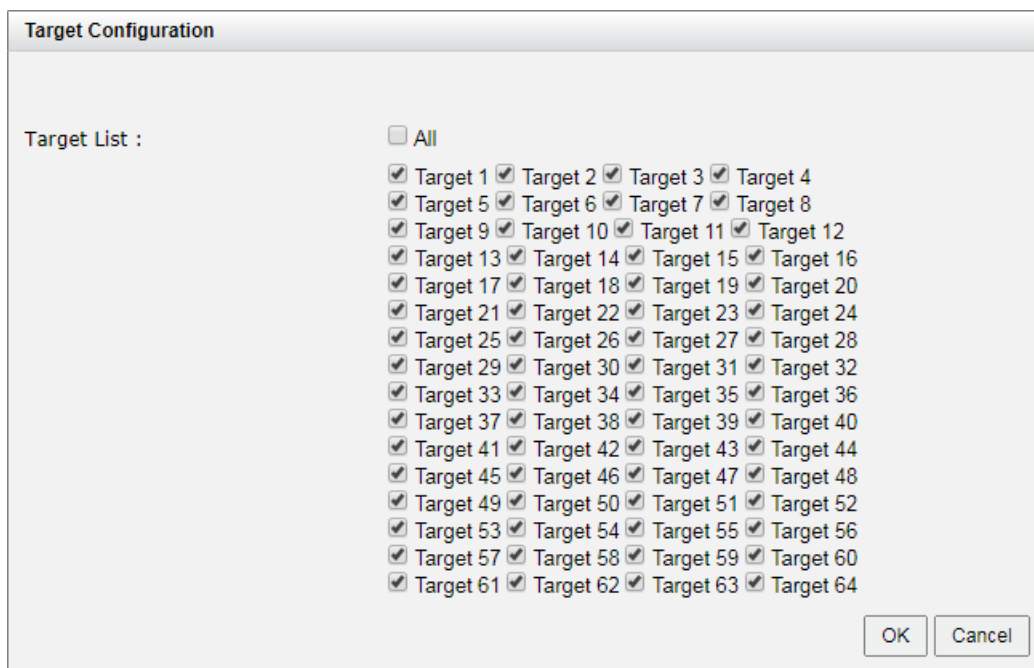

Figure 7-23 Target Configuration



CAUTION:

Point-to-Point connection mode does not support multi-target.

7.4.4. Clear Fibre Channel Counters

Click **Clear All Counters** button to clear all counters of fibre channels.

Click ▼ -> **Clear Counters** to clear the counters of the selected fibre channel.

8. Storage Management

This chapter describes storage technologies of RAID, storage pool, volume, and LUN mapping. Also includes the details of storage management operations and examples. The **STORAGE MANAGEMENT** function menu provides submenus of **Disks, Pools, Volume, and LUN Mappings**. In this chapter, we will focus on the fundamental storage architecture called thick provisioning. The advanced storage features and functions will be described in the following.

- Thin Provisioning feature is described in the [Thin Provisioning](#) chapter.
- Auto Tiering feature is described in the [Auto Tiering](#) chapter.
- SSD Cache feature is described in the [SSD Cache](#) chapter.
- SED (Self-Encrypting Drive) and ISE (Instant Secure Erase) drive support is described in the [SED and ISE Support](#) chapter.

The data backup functions are described in the following sections.

- Snapshot function is described in the [Managing Snapshots](#) section.
- Local Clone function is described in the [Manage Local Clones](#) section.
- Remote Replication function is described in the [Managing Remote Replications](#) section.

8.1. RAID Technology

RAID is the abbreviation of Redundant Array of Independent Disks. The basic idea of RAID is to combine multiple drives together to form one large logical drive. This RAID drive obtains performance, capacity and reliability than a single drive. In point view of the host, the operating system in host detects the RAID drive as a single storage device.

8.1.1. Traditional RAID Overview

The disk drives in storage are referred to as members of the array. Each array has a RAID level. RAID levels provide different degrees of redundancy and performance. They also have different restrictions regarding the quantity of member disk drives in the array. The following describe the features of RAID levels.

RAID 0 (Striping, no redundancy)

RAID 0 consists of striping, without mirroring or parity. It has more than two disks in parallel, as a large-capacity disk. The capacity of a RAID 0 volume is the sum of the capacities of the disks. There is no added redundancy for handling disk failures. Thus, failure of one disk causes the loss of the entire RAID 0 volume. Striping distributes the contents roughly equally among all member disks, which makes concurrent read or write operations on the multiple disks and results in performance improvements. The concurrent operations make the throughput of most read and write operations equal to the throughput of one disk multiplied by the quantity of disk drives. Increased throughput is the big benefit of RAID 0, at the cost of increased vulnerability of data due to drive failures.

RAID 1 (Mirroring between two disks)

RAID 1 consists of data mirroring, without parity or striping. Data is written identically to two drives, thereby producing a mirrored set of drives. Thus, any read request can be serviced by any member drive. Write throughput is always slower because every drive must be updated, and the slowest drive limits the write performance. The array continues to operate as long as at least one drive is functioning.

N-way Mirror (Mirroring between N disks)

It's an extension of RAID 1. Data is written identically to N drives, thereby producing an N-way mirrored set of drives

RAID 3 (Striping, can survive one disk drive fault, with parity on a dedicated disk drive)

RAID 3 consists of byte-level striping with dedicated parity. All disk spindle rotation is synchronized and data is striped such that each sequential byte is on a different drive. Parity is calculated across corresponding bytes and stored on a dedicated parity drive. The data disperses on a different hard drive, even if you want to read short information, it may need all the hard drives to work. So this is more suitable for large amounts of read data requests.

RAID 5 (Striping, can survive one disk drive fault, with interspersed parity over the member disk drives)

RAID 5 consists of block-level striping with distributed parity. It requires at least three disk drives. Upon failure of a single drive, subsequent reads can be calculated from the distributed parity such that no data is lost. RAID 5 is seriously affected by the general trends

regarding array rebuild time and the chance of disk drive failure during rebuild. Rebuilding an array requires reading all data from all disks, opening a chance for a second disk drive failure and the loss of the entire array.

RAID 6 (Striping, can survive two disk drive faults, with interspersed parity over the member disk drives)

RAID 6 consists of block-level striping with double distributed parity. It requires a minimum of four disks. Double parity provides fault tolerance up to two failed disk drives. This makes larger RAID groups more practical, especially for high-availability systems, as large-capacity drives take longer to restore. As with RAID 5, a single drive failure results in reduced performance of the entire array until the failed drive has been replaced. With a RAID 6 array, using drives from multiple sources and manufacturers, it is possible to mitigate most of the problems associated with RAID 5. The larger the drive capacities and the larger the array size, the more important it becomes to choose RAID 6 instead of RAID 5.

RAID 0+1 (RAID 1 on top of RAID 0)

RAID 0+1 creates a second striped set to mirror a primary striped set. The array continues to operate with one or more drives failed in the same mirror set, but if drives fail on both sides of the mirror, the data on the RAID system is lost.

RAID 10 (RAID 0 on top of RAID 1)

RAID 10 creates a striped set from a series of mirrored disk drives. The array can sustain multiple drive losses so long as no mirror loses all its drives.

RAID 30 (RAID 3 on top of RAID 0)

RAID 30 is the combination of RAID 3 and RAID 0, do RAID 3 first, further RAID 0. It is composed of multiple sets of RAID 3 stripe access to each other. Because RAID 30 is based on RAID 3 which requires at least three disk drives, therefore RAID 30 is constituted a plurality RAID 3, at least six disk drives. RAID 30 can still operate when appearing a damaged disk drive in disk group of RAID 3. But if any one group of RAID 3 appears two or two or more disk drives damaged, the entire RAID 30 will fail.

RAID 50 (RAID 5 on top of RAID 0)

RAID 50 is the combination of RAID 5 and RAID 0, do RAID 5 first, further RAID 0. The concept is the same as RAID 30. RAID 50 requires at least six disk drives. Since RAID 50

constitutes stripe of multiple disk group of RAID 5, it has higher performance than RAID 5, but capacity utilization is lower than RAID 5.

RAID 60 (RAID 6 on top of RAID 0)

RAID 60 is the combination of RAID 6 and RAID 0, do RAID 6 first, further RAID 0. In other words, it accesses stripes for more than two groups of RAID 6. RAID 6 needs to have at least four disk drives, so the minimum requirement of RAID 60 is eight disk drives.

RAID 60 can tolerate maximum two damage disk drives in any disk group of RAID 6, while it still maintains the operating, but as long as it damages three drives in any group of RAID 6, the entire RAID 60 will fail. Of course, the probability of this case is quite low.

Compared to a simple RAID 6, RAID 60 binds stripes through multiple of RAID 6. Therefore it has higher performance. However, high threshold usage and the capacity utilization rate are major problems.

RAID Level Summary

The following is the summary of the RAID levels.

Table 8-1 RAID Level Summary - 1

	RAID 0	RAID 1	RAID 3 RAID 5	RAID 6	N-way Mirror
Min. # Drives	1	2	3	4	3
Fault Tolerance	No protection	One drive failure	One drive failure	Two drive failures	N-1 drive failures
Read Performance	Very Good	Very Good	Very Good	Very Good	Very Good
Write Performance	Excellent	Good	Good	Fair to Good	Fair
Capacity (N = drive quantity, M = drive capacity, G = subgroups)	N x M (e.g., 8 drives x 1TB = 8TB)	N/2 x M (e.g., 8 drives / 2 x 1TB = 4TB)	(N-1) x M (e.g., (8 drives -1) x 1TB = 7TB)	(N-2) x M (e.g., (8 drives -2) x 1TB = 6TB)	(N/N) x M (e.g., 8 drives / 8 x 1TB = 1TB)
Capacity Utilization (Min. ~26 drives)	100% (e.g., 8/8 = 100%)	50% (e.g., 4/8 = 50%)	67% ~ 96% (e.g., 7/8 = 88%)	50% ~ 92% (e.g., 6/8 = 75%)	4% ~ 33% (e.g., 1/8 = 13%)
Typical Applications	High end workstation, Data logging, Real-time rendering, Very transitory data	Operating system, Transaction database	Data warehouse, Web service, Archive	Data archive, High Availability solution, Server with large capacity requirement	Operating system, Transaction database

8.1.2. RAID EE Overview

RAID (Redundant Array of Independent Disks) is to combine multiple independent physical disks based on a certain algorithm to form a virtual logical disk that provides a larger capacity, higher performance, or better data error tolerance. RAID has been the basic technology of storage system as a mature and reliable data protection standard. However, with the rapid growth in demand of disk drive for data storage and the advent of high-performance applications in recent years, traditional RAID has gradually revealed its defects.

As hard disk capacity increases, the amount of time required to rebuild RAID data has also dramatically increased. This makes one of the most troubles for enterprise storage management today. In the past days when the hard disk capacity was only 10GB to 100GB, RAID built was a job that could be completed in 10 minutes or even more than 10 minutes, which was not yet a problem without special concern. However, as disk capacity grows to hundreds of GB and even TB, RAID rebuild times have increased to hours or even days, it becomes a major problem in storage management.

For example, a traditional RAID 5 with 8 and 1 parity on 6TB NL-SAS disk drives takes 2.5 days to rebuild data. The rebuild process consumes system resources, reducing the overall performance of the application system. If users restrict the rebuild priority, the rebuild time will be even longer. The important of all, during time-consuming rebuilding, a large number of access operations could cause the failure of other disk drives in the pool, greatly increasing the probability of disk failure and the risk of data loss.

Limitations of Traditional RAID Architecture

The traditional RAID architecture is composed of a certain number of disk drives which are selected to form a disk group (also known as RAID group). You may also assign some disk drives as idle hot spare disk drives. A storage pool is grouped to provide capacity for volumes, and then finally map the LUN to the host to become the storage space on the host.

There are several limitations in such RAID architecture:

- First of all, when a disk drive of the disk group is damaged and the rebuild is required, only the member disks of the disk group participates in the rebuild job, and the data writing loading at the time is concentrated on the spare disk to form a bottleneck.
- Second, volume data access is limited to the member disks belonging to a disk group; this restricts the performance available to the host because the storage is executing both accessing and rebuilding I/O.

Why RAID Rebuild Time-Consuming

As drive capacity grows, RAID rebuild time grows linearly, raising the rebuild time required by traditional RAID architectures to tens of hours when using RAID disks with more than 4TB HDD capacity.

There are several factors that affect the RAID rebuild time:

- **HDD Capacity:** The HDD capacity makes up the disk group, the larger the HDD capacity, the longer the rebuild time is required.
- **Quantity of Disk Drives:** The quantity of disk drives included in a disk group affects the amount of time it takes for the system to read data from the remaining healthy disk drives and write them to the hot spare disk drives. The more disk disks, the longer the rebuild time.
- **Rebuild Job Priority:** During RAID rebuild, the system still has to assume I/O access to the front-end host. The higher the priority assigned to the RAID rebuild job, the faster the rebuild, but the less the front-end host gains I/O performance.
- **Fast Rebuild:** Enabling fast rebuild function only need to rebuild the actual capacity of the volume, unused disk group space has not to rebuild. If only part of the space in a disk group is used by the volume, the rebuild time will be shortened.
- **RAID level:** RAID 1 and RAID 10 with direct block-to-block replication will rebuild faster than RAID 5 and RAID 6 with parity calculations.

Given the potential for failure on each disk drive, the more disk drives contain in a disk group, the more possibility of cumulative failure increase, so there is an upper limit on the quantity of disk drives in a disk group. Compared with the previous factors, the increasing impact of the disk drive capacity on the rebuild speed has become the primary factor. Such a long rebuild time is apparently not acceptable to any user. To solve the problems of traditional RAID, we implement RAID EE technology.

8.1.3. Theory of RAID EE Operation

RAID EE adds more spare disks in a disk group, we call them **RAID EE spares** to separate the original global, local, and dedicated spares. Spare areas are preserved in each stripe of the disk group and are distributed in the disk group by means of disk rotation. When disks have failed in the disk group, missing data is rebuilt into the preserved spare areas. Since all disks in the set are destination of rebuilt data, the bottleneck of traditional RAID rebuild is gone, rebuild performance dramatically improved. If new disks are added in, data in spare areas are copied back to new joined disks.

Four new RAID levels are provided for RAID EE, there are:

- RAID 5EE (E stands for Enhanced), requires a minimum of 4 disk drives with one RAID EE spare disk which can tolerate 2 disk drives failure. Adding more RAID EE spares will tolerate more disk drives failure.
- RAID 6EE requires a minimum of 5 disk drives.
- RAID 50EE requires a minimum of 7 drives.
- RAID 60EE requires a minimum of 9 drives.



INFORMATION:

The RAID EE spare quantity in a disk group is 1 to 8 disk drives.

Example of RAID 5EE with 1 RAID EE spare

Now we take an example to describe how it works. The following example is a RAID 5EE with 5 disks. 4 disks are for RAID disks, and additional one disk is for RAID EE spare. After initialization, data block distribution is as follows. P is stands for parity, S is stands for RAID EE spare, and it is empty now.

D1	D2	D3	D4	D5
1	2	3	P	S
S	4	5	6	P
P	S	7	8	9
10	P	S	11	12
13	14	P	S	15

Figure 8-1 Data Block Distributed of RAID 5EE

Assume that disk 2 has failed. RAID 5EE is under degraded mode.

D1	D2	D3	D4	D5
1	2	3	P	S
S	4	5	6	P
P	S	7	8	9
10	P	S	11	12
13	14	P	S	15

Figure 8-2 Disk 2 has Failed

The spare areas are rebuilt with data from the failed disk drive. This action is called **EE Rebuild**. After rebuild, data distributed is like RAID 5 and it can tolerate another failed disk drive. As we can imagine, the more RAID EE spare disks, the faster it rebuilds.

D1		D3	D4	D5
1		3	P	2
4		5	6	P
P		7	8	9
10		P	11	12
13		P	14	15

Figure 8-3 Empty Blocks are Rebuilt from the Failed Disk Drive

When a new disk drive is joined into the RAID EE disk group, the data rebuilt in the spare area will be copied back to the new disk. This action is called **Copyback**.

D1	D2	D3	D4	D5
1	2	3	P	S
S	4	5	6	P
P	S	7	8	9
10	P	S	11	12
13	14	P	S	15

Figure 8-4 Data is copied back

After copied back, it is back to RAID 5EE normal state.

Example of RAID 60EE with 2 RAID EE spares

Take another example of a RAID 60EE with 10 disks. 8 disks are for RAID disks, and 2 disks are for RAID EE spares. After initialization, data block distribution is as follows.

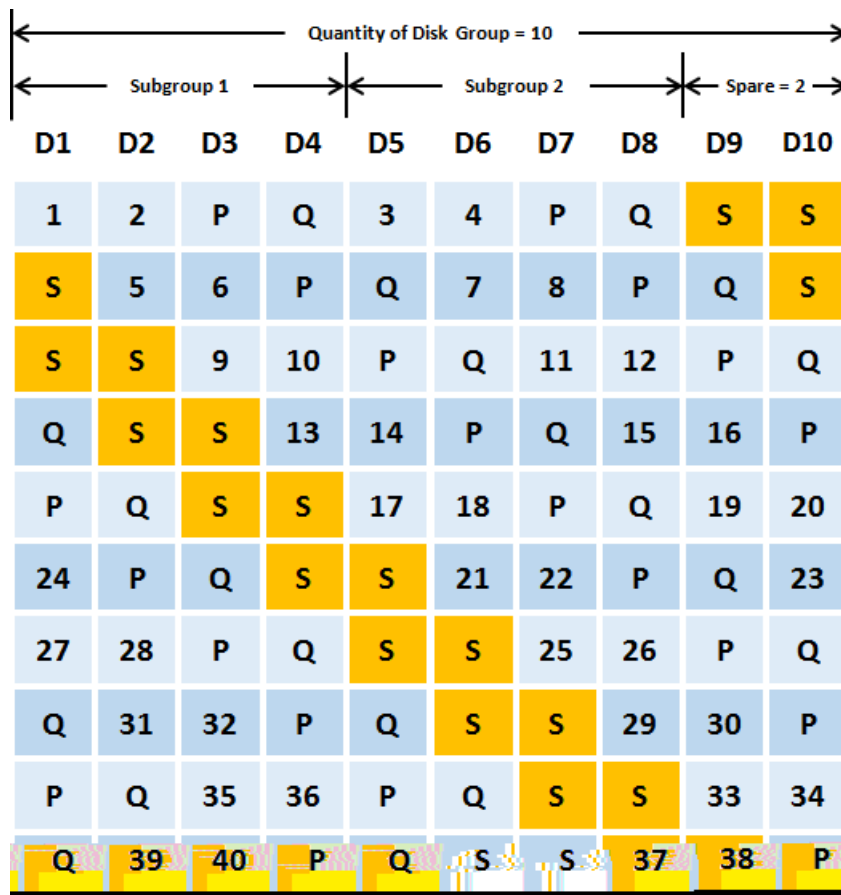

Figure 8-5 Data Block Distributed of RAID 60EE

Rebuild and copy back of RAID 60EE is similar as the above; it will not be repeated here.

RAID EE Level Summary

The following is the summary of the RAID EE levels.

Table 8-3 RAID EE Level Summary

	RAID 5EE	RAID 6EE	RAID 50EE	RAID 60EE
Min. # Drives	4	5	7	9
Fault Tolerance (G = subgroups, S = RAID EE spares = 1 ~ 8)	2 ~ 9 drive failure (e.g., 1 (RAID 5) + S spares)	3 ~ 10 drive failures (e.g., 2 (RAID 6) + S spares)	G+1 ~ G+8 drive failure (e.g., 2 subgroups (RAID 50) + S spares)	2xG+1 ~ 2xG+8 drive failures (e.g., 2x2 (RAID 60) + S spares)
Read Performance	Very Good	Very Good	Very Good	Very Good
Write Performance	Good	Fair to Good	Good	Fair to Good
Capacity (N = drive quantity, M = drive capacity, G = subgroups, S = RAID EE spares)	(N-1-S) x M (e.g., (10 drives - 1 - 2 spares) x 1TB = 7TB)	(N-2-S) x M (e.g., (10 drives - 2 -2 spares) x 1TB = 6TB)	(N-G-S) x M (e.g., (10 drives - 2 subgroups - 2 spares) x 1TB = 6TB)	(N-2xG-S) x M (e.g., (10 drives - 2 x 2 subgroups - 2 spares) x 1TB = 4TB)
Capacity Utilization (Min. ~26 drives)	18% ~ 92% (e.g., 7/10 = 70%)	17% ~ 88% (e.g., 6/10 = 60%)	29% ~ 88% (e.g., 6/10 = 60%)	25% ~ 80% (e.g., 4/10 = 40%)
Typical Applications	Same as RAID 5	Same as RAID 6	Same as RAID 50	Same as RAID 60



INFORMATION:

RAID EE technology is available in SANOS firmware 1.3.0.

8.2. SANOS Storage Architecture

This section describes the SANOS storage architecture including pool, volume, LUN mapping, and hot spares.

group containing up to 64 disk drives. And the maximum disk drive quantity in a pool is 256. For more information about pool operation, please refer to the chapter 8.4, [Configuring Thick Provisioning Pools](#) section.



INFORMATION:

To support disk group storage architecture in thick provisioning pool starts from SANOS firmware 1.2.0.

Table 8-4 Thick Provisioning Pool Parameters

Item	Value
Maximum disk group quantity in a pool	32
Maximum disk drive quantity in a disk group (include dedicated spares)	64
Maximum RAID EE spare quantity in a disk group	8
Maximum disk drive quantity in a pool (include dedicated spares)	256
Maximum pool quantity per system	64
Maximum dedicated spare quantity in a pool	8
Maximum addressable capacity of a disk group	640TB (calculated by 10TB HDD)
Maximum addressable capacity of a thick provisioning pool	2,560TB (calculated by 10TB HDD)
Maximum addressable capacity of total thick provisioning pools	Unlimited

8.2.2. Migrate vs. Add Disk Group

In thick provisioning pool, there are two methods to increase the capacity of the pool. Migration takes a long time and risk during migration. But after migration, it is more efficient than adding disk groups. By this way, it can also migrate RAID level to get a better protection.

With adding disk group, it can increase the capacity immediately but cannot change the quantity or RAID level after adding this disk group. User can evaluate the advantages and disadvantages to choose the best way.

8.2.3. Volume Technology

A volume is a logical disk that is presented to a host system. The capacity is provided by pool. Each pool can be divided into several volumes. The volumes in one pool share the same RAID level, but may have different volume capacity.

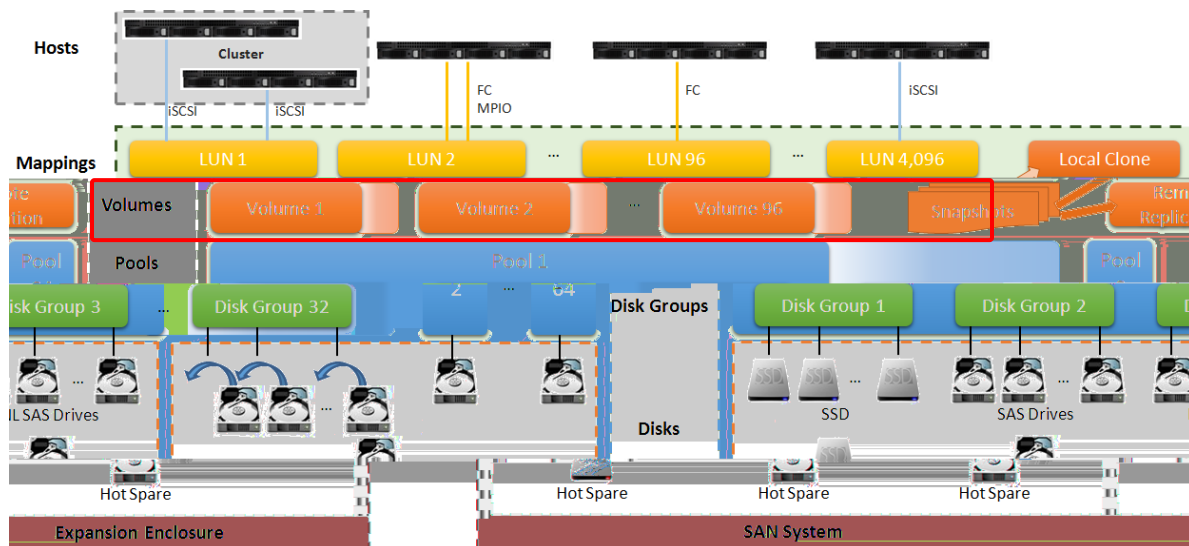

Figure 8-7 Volume in Storage Architecture

Volume is a basic unit of data backup. Base on the volume, SANOS provides snapshot, local clone, and remote replication functions. For more information about data backup, please refer to the chapter 12, [Data Backup](#) chapter.

A pool contains up to 96 volumes and a system can contain up to 4,096 volumes including snapshot volumes. For more information about volume operation, please refer to the chapter 8.5, [Configuring Volumes](#) section.

Table 8-5 Volumes Parameters

Item	Value
Maximum volume quantity in a pool	96
Maximum volume quantity per system (include snapshot volumes)	4,096
Maximum host number per volume	16
Maximum addressable volume capacity of a thick provisioning pool	2,560TB (calculated by 10TB HDD)
Maximum addressable volume capacity of a thin	256TB

provisioning pool	
Maximum addressable volume capacity of an auto tiering pool	256TB

8.2.4. LUN Technology

LUN (Logical Unit Number) is a number used to identify a logical unit, which is a device addressed by the SCSI protocol or Storage Area Network protocols which encapsulate SCSI, such as Fibre Channel or iSCSI.

The LUN is not the only way to identify a logical unit. There is also the SCSI device ID, which identifies a logical unit uniquely in the world. Labels or serial numbers stored in a logical unit's storage volume often serve to identify the logical unit. However, the LUN is the only way for an initiator to address a command to a particular logical unit, so initiators often create, via a discovery process, a mapping table of LUN to other identifiers.

There is one LUN which is required to exist in every target: LUN 0. The logical unit with LUN 0 is special in that it must implement a few specific commands, most notably report LUNs, which is how an initiator can find out all the other LUNs in the target. LUN 0 does not provide any other services, such as a storage volume. Many SCSI targets contain only one logical unit (so its LUN is necessarily 0). Others have a small number of logical units that correspond to separate physical devices and have fixed LUNs. A large storage system may have up to thousands of logical units, defined logically, by administrative command, and the administrator may choose the LUN or the system may choose it.

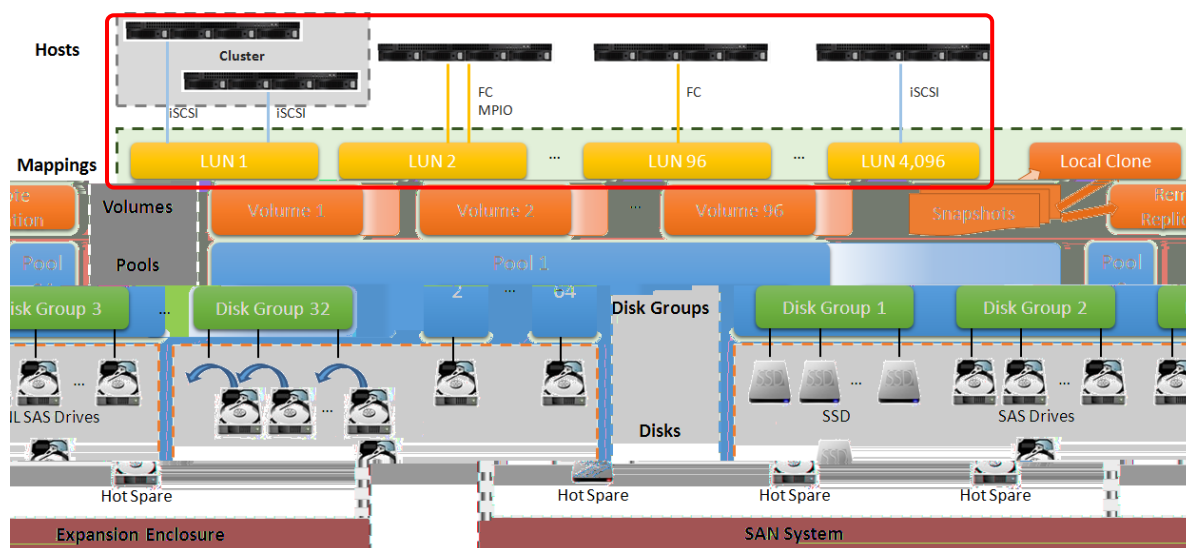

Figure 8-8 LUN Mappings in Storage Architecture

Volumes are then allocated out of the storage pool and are mapped to LUN which can be accessed by a host system. In Figure 8-3, a LUN can be accessed by cluster with two or more hosts via iSCSI. Or can be accessed by MPIO to provide HA (High Availability) architecture and increase the access bandwidth. The snapshot volumes can also be mapped to a LUN. The same, the read-only snapshot LUN can be read by the host, and the writable snapshot LUN can be read/write.

A SANOS system can contain up to 4,096 LUNs which includes the total of volume LUN mappings and snapshot volume LUN mappings.

Table 8-6 LUN Parameters

Item	Value
Maximum LUN quantity per system	4,096

For more information about LUN mapping operation, please refer to the chapter 8.6, [Configure LUN Mappings](#) section.

8.2.5. Hot Spares

A hot spare disk is a disk used to automatically or manually replace a failing or failed disk in a RAID configuration. The hot spare disk reduces the MTTR (Mean Time To Recovery) for the RAID redundancy group, thus reducing the probability of a second disk failure and the resultant data loss that would occur in any singly redundant RAID (e.g., RAID 1, RAID 5, or RAID 10). Typically, a hot spare is available to replace some different disks and systems employing a hot spare normally require a redundant group to allow time for the data to be generated onto the spare disk. During this time the system is exposed to data loss due to a subsequent failure, and therefore the automatic switching to a spare disk reduces the time of exposure to that risk compared to manual discovery and implementation.

If one disk drive of the pool fails or has been removed from any singly redundant RAID, the pool status will change to degraded mode. At the moment, the SANOS system will search the spare disk to

- **Local Spare:** Set a spare disk drive to the pools which located in the same enclosure. The enclosure is either in head unit or in one of expansion units.
- **Global Spare:** Set a spare disk drive to all pools which located whether in head unit and expansion unit.

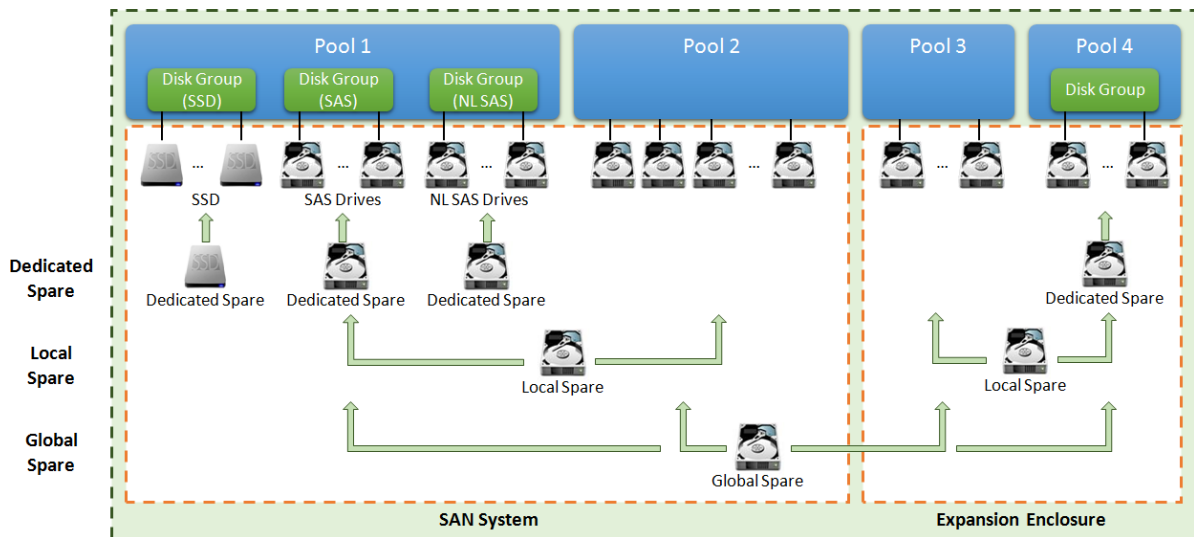

Figure 8-9 Hot Spares

When a member disk of the pool fails, the system will first search for a dedicated spare disk for the pool, if not present, search for a local spare instead, then eventually global spare disk. For more information about spare disk operation, please refer to the chapter 8.3.2, [Operations on Disks](#) section.

8.3. Working with Disk Drives

Select the **Disks** function submenu to display the status of the disk drives, set hot spares, check disk health, and update disk firmware. The entire SAN storage system can contain up to 10 expansion enclosures and 286 disk drives.

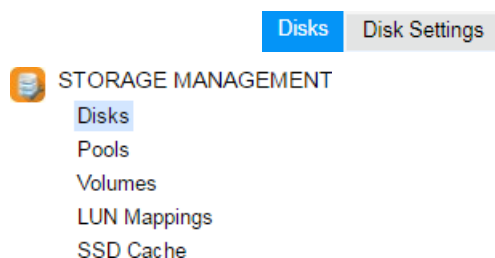

Figure 8-10 Disks Function Submenu



INFORMATION:

For deployment of the SAN system and expansion enclosures, please refer to the chapter 4, Deployment Types and Cabling in the [XCubeSAN Hardware Manual](#).

Table 8-7 Enclosure and Disk Parameters

Item	Value
Maximum expansion unit quantity in a system	10
Maximum disk quantity in a system	286

8.3.1. List Disks

The drop-down lists at the top enable you to select the enclosure from head unit (SAN system) or expansion units (expansion enclosures). The disk properties can be configured by clicking the functions button ▼ to the left side of the specific disk drive.



INFORMATION:

Enclosure format: Enclosure ID ([Head Unit | Expansion Unit]: Model Name). For example: 0 (Head Unit: XS5216), 1 (Expansion Unit: XD5316)

Enclosure ID: 0 (Head Unit: X55216) ▾

<< first < prev 1 next > last >>

Slot	Status	Health	Encryption	SED / ISE Status	Capacity	Disk Type	Usage	Pool Name	Manufacturer	Model		
1	Online	Good	None	N/A	372.36 GB	SAS SSD 12.0Gb/s	Free		SEAGATE	ST400FM0053		
2	Free			SEAGATE	ST400FM0053	2	Online	Good	None	N/A	372.36 GB	SAS
3	Free			SEAGATE	ST400FM0053	3	Online	Good	None	N/A	372.36 GB	SAS
4	Free			SEAGATE	ST400FM0053	4	Online	Good	None	N/A	372.36 GB	SAS
5	Free			MICRON	S630DC-800	5	Online	Good	None	N/A	744.96 GB	SAS
6	Free			MICRON	S630DC-800	6	Online	Good	None	N/A	744.96 GB	SAS
7	Free			MICRON	S630DC-800	7	Online	Good	None	N/A	744.96 GB	SAS
8	Free			MICRON	S630DC-800	8	Online	Good	None	N/A	744.96 GB	SAS
9	Free			SEAGATE	ST1200MM0088	9	Online	Good	None	N/A	1.09 TB	SAS
10	Free			SEAGATE	ST1200MM0088	10	Online	Good	None	N/A	1.09 TB	SAS HDD 12.0Gb/s
11	Free			SEAGATE	ST1200MM0088	11	Online	Good	None	N/A	1.09 TB	SAS HDD 12.0Gb/s
12	Free			SEAGATE	ST1200MM0088	12	Online	Good	None	N/A	1.09 TB	SAS HDD 12.0Gb/s
13	Free			SEAGATE	ST6000NM0014	13	Online	Good	None	N/A	5.46 TB	NL-SAS HDD 12.0Gb/s
14	Free			SEAGATE	ST6000NM0014	14	Online	Good	None	N/A	5.46 TB	NL-SAS HDD 12.0Gb/s
15	Free			SEAGATE	ST6000NM0014	15	Online	Good	None	N/A	5.46 TB	NL-SAS HDD 12.0Gb/s
16	Free			SEAGATE	ST6000NM0014	16	Online	Good	None	N/A	5.46 TB	NL-SAS HDD 12.0Gb/s

<< first < prev 1 next > last >>

Figure 8-11 List Disks

This table shows the column descriptions.

Table 8-8 Disk Column Descriptions

Column Name	Description
Slot	The position of the disk drive.
Status	The status of the disk drive: <ul style="list-style-type: none"> Online: The disk drive is online. Rebuilding: The disk drive is being rebuilt. Transitioning: The disk drive is being migrated or is replaced by another disk when rebuilding occurs. Scrubbing: The disk drive is being scrubbed. Check Done: The disk drive has been checked the disk health. Copying Back: The disk drive is being copied back.
Health	The health of the disk drive: <ul style="list-style-type: none"> Good: The disk drive is good. Failed: The disk drive has failed. Error Alert: S.M.A.R.T. error alerts. Read Errors: The disk drive has unrecoverable read errors.
Encryption	The data security mode of the disk drive:

	<ul style="list-style-type: none"> • SED: The disk drive is a Self-Encrypting Drive. • ISE: The disk drive is an Instant Secure Erase drive. • None: The disk drive does not have encryption function.
SED / ISE Status	<p>The status of the SED:</p> <ul style="list-style-type: none"> • Enabled: The SED is enabled. • Locked: The SED is locked. It must be unlocked by the correct AK before it can be used. • Disabled: The SED is disabled. It must be initiated before it can be used. • Password Locked: The SED is locked by entering the incorrect password too many times. • Unknown: The SED is unknown. • Initiating: The SED is being initiated. • Unlocking: The SED is being unlocked. • Erasing: The SED is being erased. • Changing Key: The SED is being changed the key. <p>The status of the ISE:</p> <ul style="list-style-type: none"> • Normal: The ISE is normal. • Erasing: The ISE is being erased. • Unknown: The ISE is unknown. <p>The status of the Non SED/ISE:</p> <ul style="list-style-type: none"> • N/A: The field is not applicable.
Capacity	The capacity of the disk drive.
Disk Type	<p>The type of the disk drive:</p> <ul style="list-style-type: none"> • [SAS HDD NL-SAS HDD SAS SSD SATA SSD] • [12.0Gb/s 6.0Gb/s 3.0Gb/s 1.5Gb/s]
Usage	<p>The usage of the disk drive:</p> <ul style="list-style-type: none"> • Free: This disk drive is free for use. • RAID: This disk drive has been set to a pool. • SSD Cache: This SSD has been set to an SSD cache pool. • Dedicated Spare: This disk drive has been set as dedicated spare of a pool. • Local Spare: This disk drive has been set as local spare of the enclosure. • Global Spare: This disk drive has been set as global spare of whole system.

	<ul style="list-style-type: none"> • SSD Spare: This SSD has been set as dedicated SSD spare of an SSD cache pool.
Pool Name	Which pool the disk drive belongs to.
Manufacturer	The manufacturer of the disk drive.
Model	The model name of the disk drive.

8.3.2. Operations on Disks

The options are available in this tab:

Disk Health Check

Click the **Disk Health Check** button to check the health of the selected disks. Also select the quantity of bad block to stop disk health check. And then click **OK** button to proceed. It cannot check disks which are currently in use.



Figure 8-12 Disk Health Check

Disk Check Report

Click the **Disk Check Report** button to download the disk check report. It's available after executing **Disk Health Check**.

Set Free Disk

Click ▼ -> **Set Free Disk** to make the selected disk drive be free for use.

Set Spare Disk

Click ▼ -> **Set Global Spare** to set the selected disk drive to global spare of all pools which located whether in head unit and expansion unit.

Click ▼ -> **Set Local Spare** to set the selected disk drive to local spare of the pools which located in the same enclosure. The enclosure is either in head unit or in one of expansion units.

Click ▼ -> **Set Dedicated Spare** to set the disk drive to dedicated spare of the selected pool.

For more information about hot spares, please refer to the chapter 8.2.4, [Hot Spares](#) section and the chapter 15.2, [Rebuild](#) section in the Troubleshooting chapter. Here is an example how to set a spare disk to a dedicated pool.

1. Select a free disk, and then click ▼ -> Set Dedicated Spare.

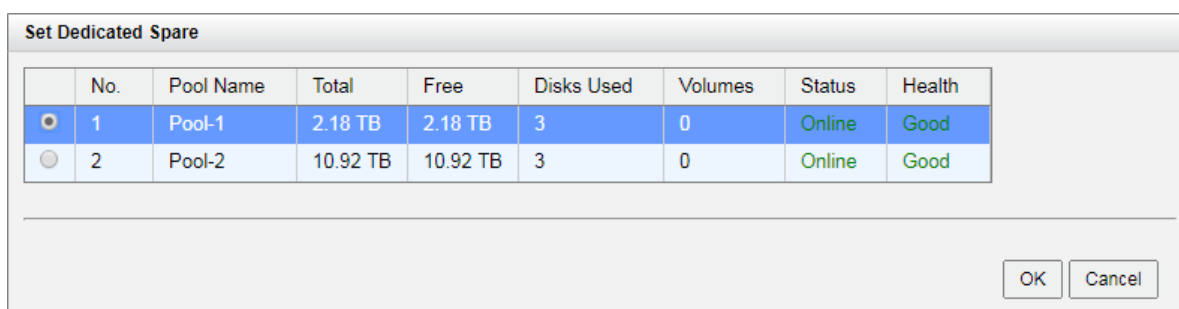

Figure 8-13 Set Dedicated Spare

2. Select the pool which the disk drive is set to its dedicated spare, and then click **OK** button.

Disk Scrub and Clear Disk Read Error

Click ▼ -> **Disk Scrub** to scrub the disk drive. It's not available when the disk drive is in used.

Click ▼ -> **Clear Disk Read Error** to clean the read error of the disk drive and reset the failed status.

Update Disk Firmware

Click ▼ -> **Update Disk Firmware** to upgrade the firmware of the disk drive.

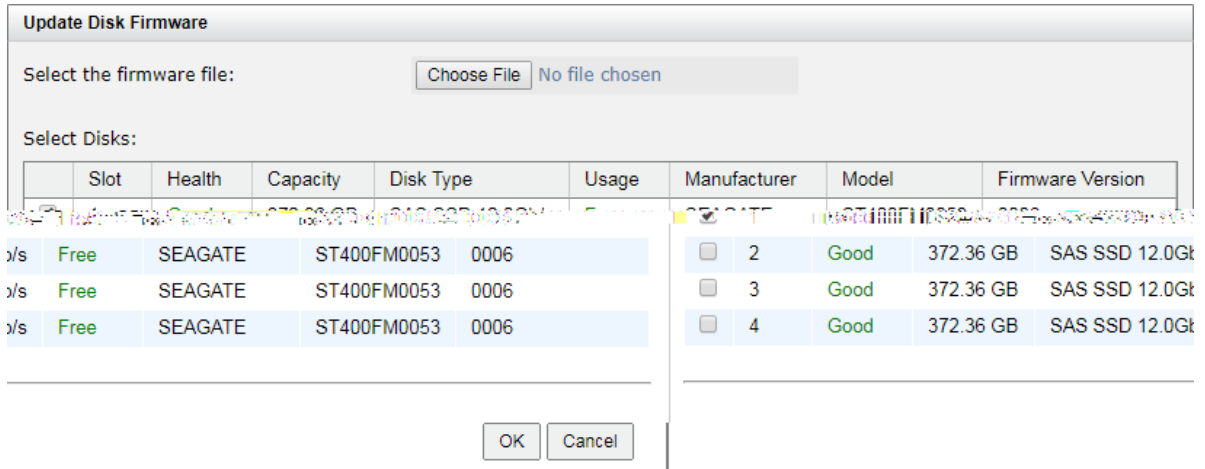

Figure 8-14 Update Disk Firmware



CAUTION:

If the disk to be updated firmware is a member of the pool and there are multiple disks of the same model, it is not recommended to update all at the same time. You need to set one disk to idle and then update the disk firmware. After completion, perform pool rebuild and then execute the next disk firmware update. These steps will avoid the risk of data loss.

Turn on Disk LED

Click ▼ -> **Turn on Disk LED** to turn on the indication LED of the disk drive.

Turn off Disk LED

Click ▼ -> **Turn off Disk LED** to turn off the indication LED of the disk drive.

S.M.A.R.T.

Click ▼ -> **S.M.A.R.T.** to show the S.M.A.R.T. information of the disk drive. For more information about S.M.A.R.T., please refer to the chapter 8.3.3, [S.M.A.R.T.](#) section

More Information of the Disk

Click ▼ -> **More Information** to show the detail information of the disk drive.

More Information

Location and Status

Item	Information
Enclosure ID	0
Slot	1
Status	Online
Health	Good

Disk Information

Item	Information
Manufacturer	SEAGATE
Model	ST400FM0053
Serial Number(s)	Z3F010RT0000Z3F010RT
Capacity	372.36 GB
Disk Type	SAS SSD 12.0Gb/s
Disk Firmware Version	0006

Disk Properties

Item	Information
Disk Write Cache	Enabled
Disk Read-ahead	Enabled
Disk Command Queuing	Enabled
Disk Standby	Disabled

Storage Properties

Item	Information
Usage	Free

Close

Figure 8-15 More Information of Disk Drive

8.3.3. S.M.A.R.T.

S.M.A.R.T. (Self-Monitoring Analysis and Reporting Technology) is a diagnostic tool for disk drives to deliver warning of drive failures in advance. It provides users a chance to take actions before a possible drive failure.

S.M.A.R.T. measures many attributes of disk drives all the time and inspects the properties of disk drives which are close to being out of tolerance. The advanced notice of possible disk drive failure will allow users to back up the data of disk drive or replace the disk drive.

This is much better than a disk drive crash when it is writing data or rebuilding a failed disk drive.

Select a disk drive and click ▼ -> **S.M.A.R.T.**.....

Figure 8-17 S.M.A.R.T. Attributes of SSD

For some SSDs, we provide SSD endurance values to monitor the health of SSDs. The value is a percentage to know how much remaining life of SSD is. The system will notify user if the SSD endurance is under 10%. And also 5%, 3%, 2% by sequence.

TIP:

Although it's a useful reference value to know the remaining life of the SSD, we recommend replacing the SSD if the value is under 5%.

INFORMATION:

SAS/SATA

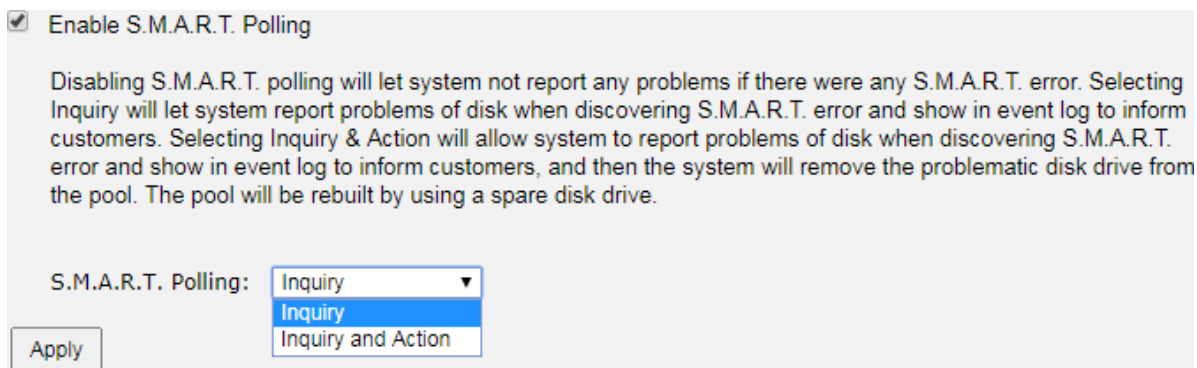

Figure 8-18 Disk Settings



INFORMATION:

S.M.A.R.T. polling setting is available in SANOS firmware 1.3.0.

8.4. Configure Thick Provisioning Pools

Select the **Pools** function submenu to create, modify, delete, or view the status of the pools. We will describe thick provisioning pool in the following section; keep thin provisioning technology in the [Thin Provisioning](#) chapter and auto tiering in the [Auto Tiering](#) chapter.

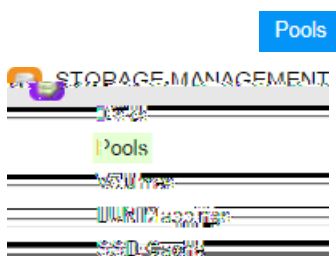

Figure 8-19 Pools Function Submenu

8.4.1. Create a Thick Provisioning Pool

Here is an example of creating a thick provisioning pool with 4 disks configured in RAID 5. At the first time of creating a thick provisioning pool, it contains a disk group and the maximum quantity of disk in a disk group is 64.

1. Select the **Pools** function submenu, click the **Create Pool** button. It will scan available disks first.



TIP:

It may take 20 ~ 30 seconds to scan disks if your system has more than 200 disk drives. Please wait patiently.

Create Pool

General

- Disk Selection
- RAID Configuration
- Disk Properties
- Summary

Pool Type

Please select a pool type.

- Thick Provisioning
- Thin Provisioning

Pool Properties

Please enter a pool name and select preferred controller setting.

Pool Name : ⓘ

Preferred Controller : ▾

The I/O resources will be managed by the preferred controller which you specified.

SED Pool

- Enable SED Pool

Enabling SED pool will use the secure SEDs to create a pool. Intermixing SEDs and non-SEDs are not supported in a pool.

Next Cancel

Figure 8-20 Create a Thick Provision Pool Step 1

2. Select the **Pool Type** as Thick Provisioning.
3. Enter a **Pool Name** for the pool. Maximum length of the pool name is 16 characters. Valid characters are [A~Z | a~z | 0~9 | -_<>].

4. Select a **Preferred Controller** from the drop-down list. The backend I/O resources in this pool will be processed by the preferred controller which you specified. This option is available when dual controllers are installed.
5. Check the **Enable SED Pool** checkbox. Enabling SED pool will use the secure SEDs to create a pool. Intermixing SEDs and non-SEDs are not supported in a pool.
6. Click the **Next** button to continue.

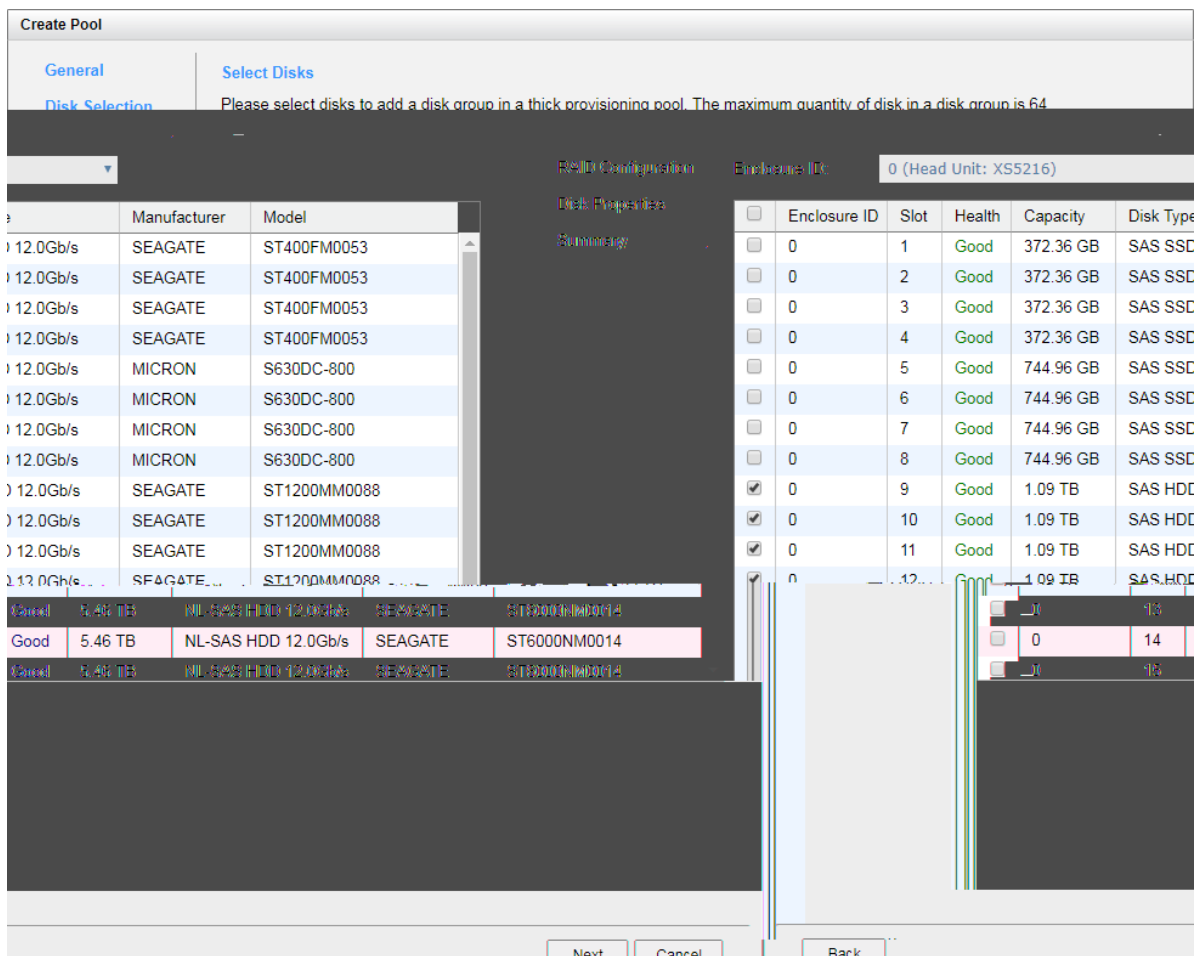

Figure 8-21 Create a Thick Provision Pool Step 2

7. Please select disks for pool. The maximum quantity of disk in a disk group is 64. Select an **Enclosure ID** from the drop-down list to select disks from expansion enclosures.
8. Click the **Next** button to continue.

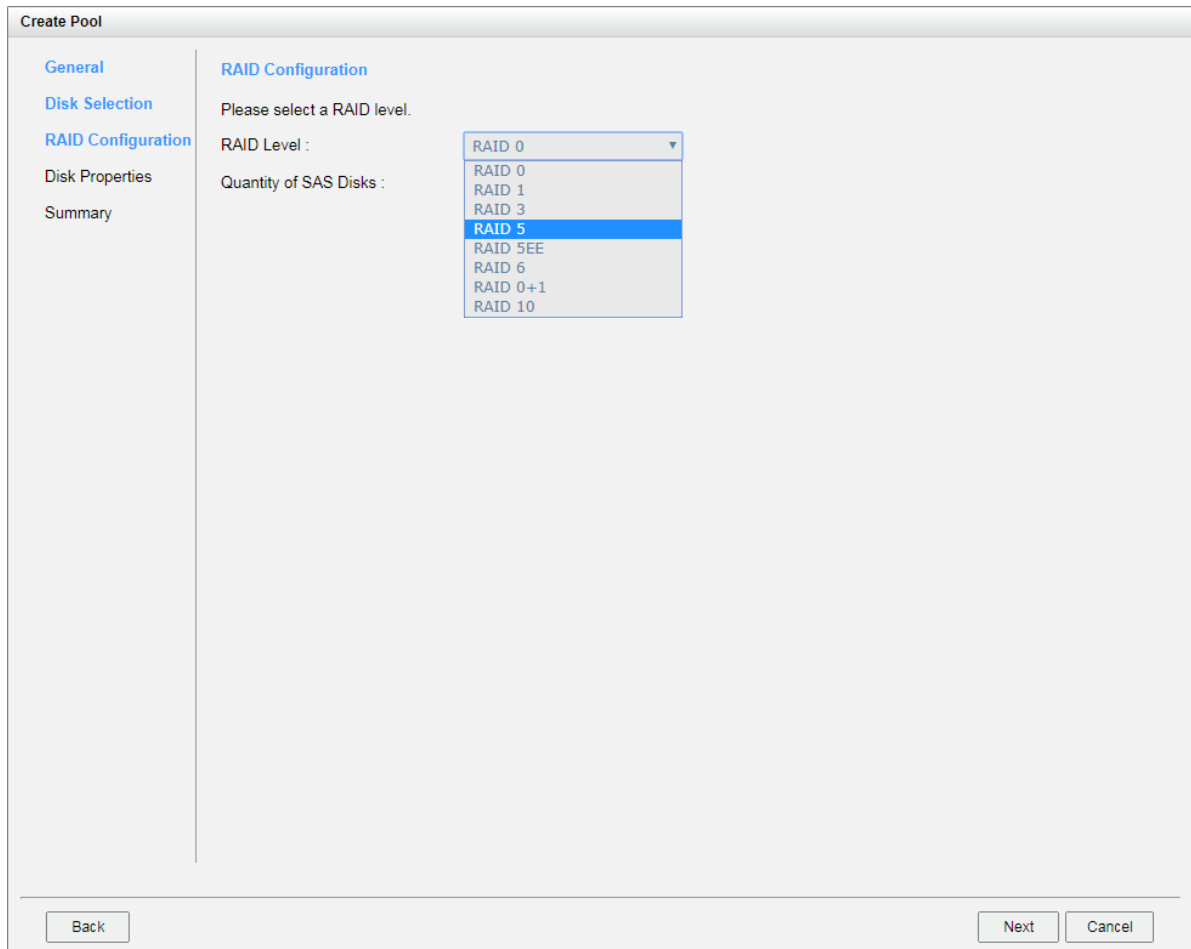

Figure 8-22 Create a Thick Provision Pool Step 3

9. Select a **RAID Level** from the drop-down list which lists available RAID level only according to the disk selection. And also select a **Quantity of Subgroups** if the combination RAID level is selected.
10. Click the **Next** button to continue.

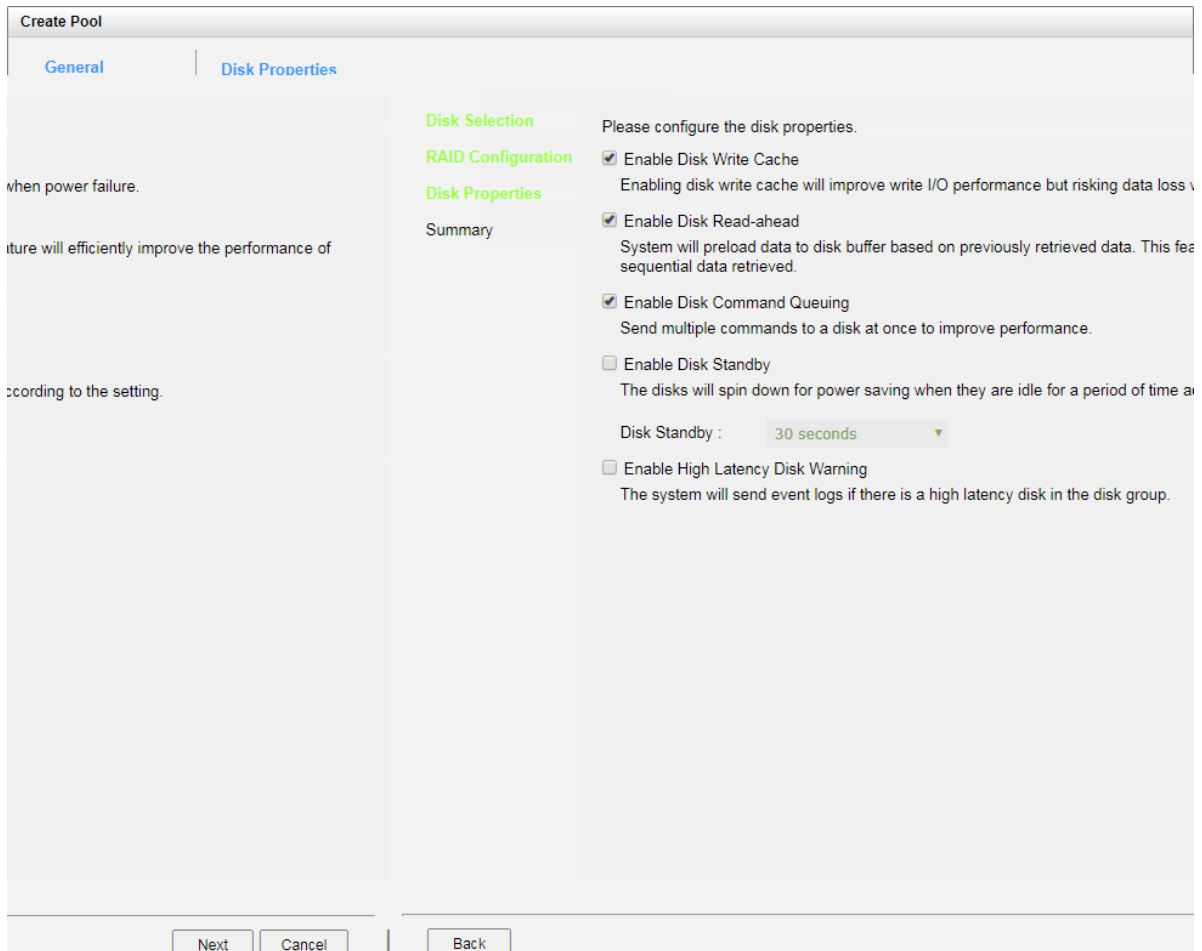

Figure 8-23 Create a Thick Provision Pool Step 4

11. Disk properties can also be configured optionally in this step:

Enable Disk Write Cache: Check to enable the write cache option of disks. Enabling disk write cache will improve write I/O performance but have a risk of losing data when power failure.

Enable Disk Read-ahead: Check to enable the read-ahead function of disks. System will preload data to disk buffer based on previously retrieved data. This feature will efficiently improve the performance of sequential data retrieved.

Enable Disk Command Queuing: Check to enable the command queue function of disks. Send multiple commands to a disk at once to improve performance.

Enable Disk Standby: Check to enable the auto spin down function of disks. The disks will be spun down for power saving when they are idle for the period of time specified.

Enable High Latency Disk Warning: Check to enable the high latency disk warning function in a disk group. When a disk drive is abnormal with high latency, the system

will send event logs to notify IT administrators in advance to avoid affecting overall performance.

12. Click the **Next** button to continue.

Figure 8-24 Create a Thick Provision Pool Step 5

13. After confirmation at summary page, click the **Finish** button to create a pool.

	Pool Name	Status	Health	Total	Free	Available	Thin Provisioning	Encryption	Volumes	Current Controller
▼	Pool-1	Online	Good	3.27 TB	3.27 TB	3.27 TB	Disabled	Disabled	0	Controller 1

Create Pool

Figure 8-25 A Thick Provisioning Pool is Created

14. A pool has been created. If necessary, click **Create Pool** button again to create others.

8.4.2. List Thick Provisioning Pools

Click a pool; it will display the related disk groups. Similarly, click a disk group; it will display the related disk drives. The pool properties can be configured by clicking the functions button ▼ to the left side of the specific pool.

	Pool Name	Status	Health	Total	Free	Available	Thin Provisioning	Encryption	Volumes	Current Controller
▼	Pool-1	Online	Good	3.27 TB	3.27 TB	3.27 TB	Disabled	Disabled	0	Controller 1

Disk Groups

	No.	Status	Health	Total	Free	RAID	Disks Used	RAID EE Spares
▼	1	Online	Good	3.27 TB	3.27 TB	RAID 5	4	N/A

Disks

Enclosure ID	Slot	Status	Health	Capacity	Disk Type	Manufacturer	Model
[Redacted]							

Figure 8-26 List Thick Provisioning Pools

This table shows the column descriptions.

Table 8-9 Pool Column Descriptions

Column Name	Description
Pool Name	The pool name.
Status	The status of the pool: <ul style="list-style-type: none"> • Online: The pool is online. • Offline: The pool is offline. • Rebuilding: The pool is being rebuilt. • Migrating: The pool is being migrated. • Relocating: The pool is being relocated. • EE Rebuilding: The pool is being RAID EE rebuilt.
Health	The health of the pool: <ul style="list-style-type: none"> • Good: The pool is good.

	<ul style="list-style-type: none"> • Failed: The pool has failed. • Degraded: The pool is unhealthy and incomplete. The cause may be a disk loss or failure.
Total	Total capacity of the pool.
Free	Free capacity of the pool.
Available	Available capacity of the pool.
Thin Provisioning	The status of Thin provisioning: <ul style="list-style-type: none"> • Disabled. • Enabled.
Encryption	The Data Secure Mode: <ul style="list-style-type: none"> • Disabled: The pool is not encrypted. • Enabled: The pool is encrypted.
Volumes	The quantity of volumes in the pool.
Current Controller <i>(This option is only visible when dual controllers are installed.)</i>	The current running controller of the pool.

Table 8-10 Disk Group Column Descriptions

Column Name	Description
No.	The number of the disk group.
Status	The status of the disk group: <ul style="list-style-type: none"> • Online: The disk group is online. • Offline: The disk group is offline. • Rebuilding: The disk group is being rebuilt. • Migrating: The disk group is being migrated. • Relocating: The disk group is being relocated. • EE Rebuilding: The disk group is being RAID EE rebuilt.
Health	The health of the disk group: <ul style="list-style-type: none"> • Good: The disk group is good. • Failed: The disk group has failed. • Degraded: The disk group is not healthy and not complete. The reason could be missing or failed disks.
Total	Total capacity of the disk group.
Free	Free capacity of the disk group.

RAID	The RAID level of the disk group.
Disks Used	The quantity of disk drives in the disk group.
RAID EE Spare	The quantity of RAID EE spare disk drives in the disk group. Traditional RAID level is display as N/A.

Table 8-11 Disk Column Descriptions

Column Name	Description
Enclosure ID	The enclosure ID.
Slot	The position of the disk drive.
Status	The status of the disk drive: <ul style="list-style-type: none"> • Online: The disk drive is online. • Missing: The disk drive is missing in the pool. • Rebuilding: The disk drive is being rebuilt. • Transitioning: The disk drive is being migrated or is replaced by another disk when rebuilding occurs. • Scrubbing: The disk drive is being scrubbed. • Check Done: The disk drive has been checked the disk health. • Copying Back: The disk drive is being copied back.
Health	The health of the disk drive: <ul style="list-style-type: none"> • Good: The disk drive is good. • Failed: The disk drive has failed. • Error Alert: S.M.A.R.T. error alerts. • Read Errors: The disk drive has unrecoverable read errors.
Capacity	The capacity of the disk drive.
Disk Type	The type of the disk drive: <ul style="list-style-type: none"> • [SAS HDD NL-SAS HDD SAS SSD SATA SSD] • [12.0Gb/s 6.0Gb/s 3.0Gb/s 1.5Gb/s]
Manufacturer	The manufacturer of the disk drive.
Model	The model name of the disk drive.

8.4.3. Operations on Thick Provisioning Pools

The options are available in this tab:

Activate or Deactivate the Pool

Click ▼ -> **Activate/Deactivate** in one of pools, these options are usually used for online disk roaming. Deactivate can be executed when the status is online. Conversely, activate

can be executed when the pool status is offline. For more information, please refer to the chapter 8.8, [Disk Roaming](#) section.

Change Disk Properties of the Pool

Click ▼ -> **Change Disk Properties** in one of pools to change disk properties of the pool.

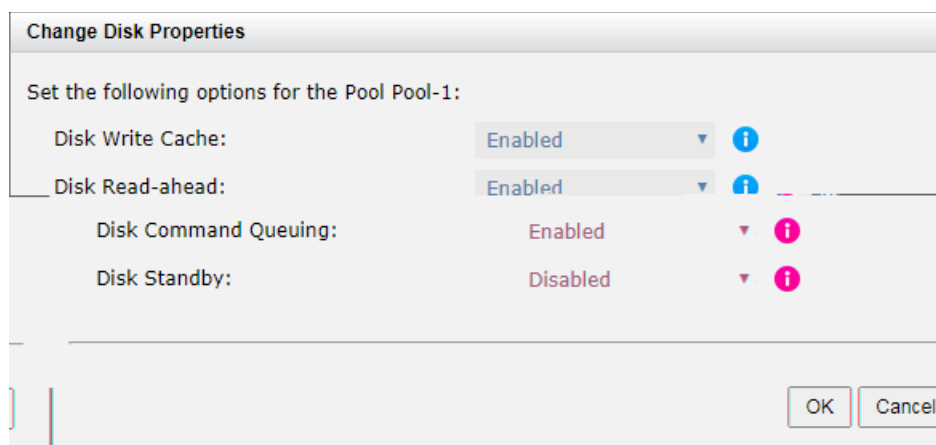

Figure 8-27 Change Disk Properties

Change Thin Provisioning Policy of the Pool

Click ▼ -> **Change Thin Provisioning Policy** in one of pools to change policy of the thin provisioning pool. For more information, please refer to the chapter 9, [Thin Provisioning](#).

Change Preferred Controller of the Pool

Click ▼ -> **Change Preferred Controller** in one of pools to change the pool ownership to the other controller.

Verify Parity of the Pool

Click ▼ -> **Verify Parity** in one of pools to regenerate parity for the pool. It supports RAID level 3, 5, 6, 30, 50, 60 and RAID EE level 5EE, 6EE, 50EE, 60EE.

Add a Disk Group into the Pool

Click ▼ -> **Add Disk Group** in one of pools to add another disk group into the pool. For more information, please refer to the chapter 8.4.5, [Add a Disk Group in a Thick Provisioning Pool](#) section.

If the auto tiering license is enabled, you can click ▼ -> **Add Disk Group** in one of pools to transfer from the thick provisioning pool to auto tiering pool. For more information, please refer to the chapter 11.7, [Transfer to Auto Tiering Pool](#) section.

Add Disk Group

Pool Type

Thin Provisioning : Disabled

Auto Tiering : Disabled ▼ ⓘ

Disabled

Enabled

RAID Level

Please select a RAID level.

RAID Level : RAID 1 ▼

Select Disks

Please select disks to add a disk group. The maximum quantity of disk in a disk group is 64.

Enclosure ID : 0 (Head Unit: XS5216) ▼

<input type="checkbox"/>	Enclosure ID	Slot	Health	Capacity	Disk Type	Manufacturer	Model
<input type="checkbox"/>	0	1	Good	372.36 GB	SAS SSD 12.0Gb/s	SEAGATE	ST400FM0053
<input type="checkbox"/>	0	2	Good	372.36 GB	SAS SSD 12.0Gb/s	SEAGATE	ST400FM0053
<input type="checkbox"/>	0	3	Good	372.36 GB	SAS SSD 12.0Gb/s	SEAGATE	ST400FM0053
<input type="checkbox"/>	0	4	Good	372.36 GB	SAS SSD 12.0Gb/s	SEAGATE	ST400FM0053
<input checked="" type="checkbox"/>	0	5	Good	744.96 GB	SAS SSD 12.0Gb/s	MICRON	S630DC-800
<input checked="" type="checkbox"/>	0	6	Good	744.96 GB	SAS SSD 12.0Gb/s	MICRON	S630DC-800

Figure 8-28 Transfer Thick Provisioning Pool to Auto Tiering



CAUTION:

The action of transferring from the thick provisioning pool to auto tiering is irreversible. Consider all possible consequences before making this change.

Delete a Pool

Click ▼ -> **Delete** to delete the pool. The pool cannot be deleted when there are volumes in the pool.

More Information of the Pool

Click ▼ -> **More Information** to show the detail information of the pool.

8.4.4. Migrate a Disk Group in a Thick Provisioning Pool

The **Migrate Disk Group** function changes the disk group to a different RAID level or adds the member disks of the disk group to increase the capacity. Each disk group is independent, you can migrate each one of disk groups.

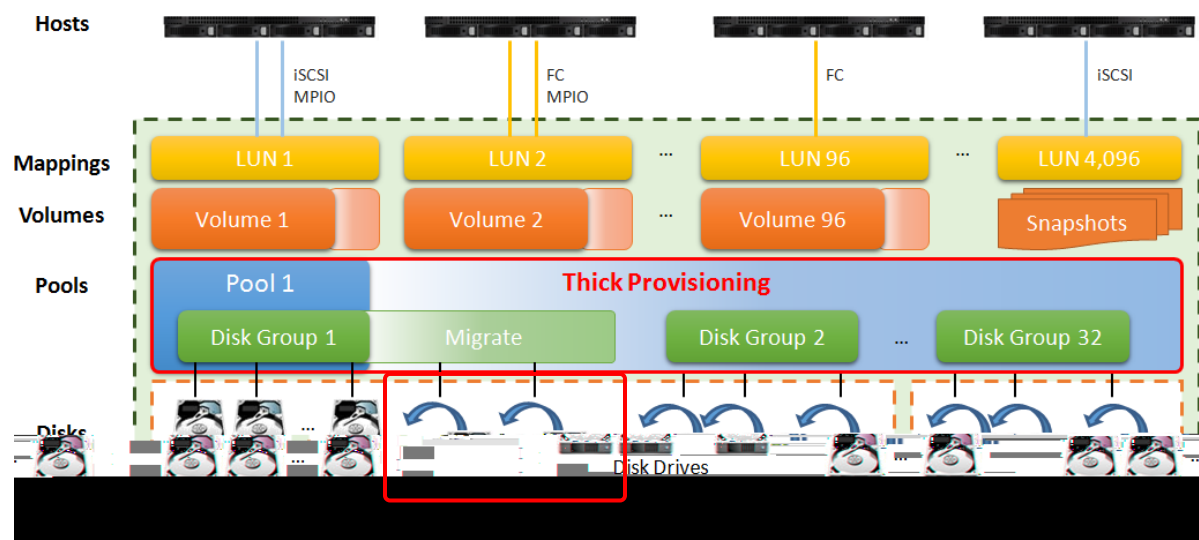

Figure 8-29 Migrate a Disk Group in a Thick Provisioning Pool

Usually, the disk group migrates to higher RAID level for better protection. To perform a migration, the total capacity of the disk group must be larger than or equal to the original one. If the RAID level doesn't change, the migration can also move the member disk drives to completely different disk drives.

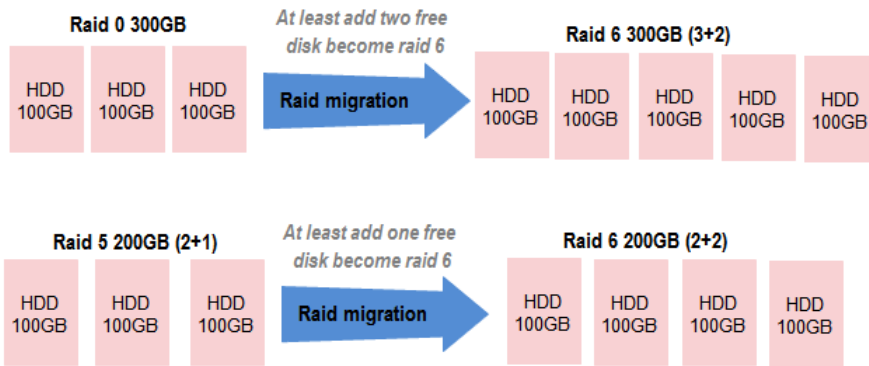

Figure 8-30 RAID Migration

Here's an example of migrate a disk group from RAID 5 to RAID 6.

1. Select a disk group, and then click ▼ -> **Migrate Disk Group**

Figure 8-31 Migrate RAID Level Step 1

2. Select a **RAID Level** from the drop-down list.
3. Please select disks for pool. The maximum quantity of disk in a disk group is 64. Select an **Enclosure ID** from the drop-down list to select disks from expansion enclosures.
4. Click the **OK** button to execute migration.
5. Migration starts. The status of the **Disks, Pools** and **Volumes** are changing. The complete percentage of migration is displayed in the **Status**.
6. It's done when the complete percentage reaches 100%.

**INFORMATION:**

There are some operation limitations when a pool is being migrated.

- The capacity after migration must be larger than the current capacity.
 - A traditional RAID level can be migrated to RAID EE level, but RAID EE level can be migrated to RAID EE level only.
-

**INFORMATION:**

There are some operation limitations when a pool is being migrated. The System would reject these operations:

- Add dedicated spare.
 - Remove a dedicated spare.
 - Create a new volume.
 - Delete a volume.
 - Extend a volume.
 - Scrub a volume.
 - Perform another migration operation.
 - Scrub entire pool.
 - Take a snapshot.
 - Delete a snapshot.
 - Expose a snapshot.
 - Rollback to a snapshot.
-

**TIP:**

Pool migration cannot be executed during rebuilding or volume extension.

**TIP:**

Thin provisioning pool cannot execute the **Migrate Disk Group** option; it uses the **Add Disk Group** option to enlarge the capacity. For more information, please refer to the chapter 9, [Thin Provisioning](#).

8.4.5. Add a Disk Group in a Thick Provisioning Pool

The **Add Disk Group** function adds a disk group to a pool to increase the capacity.

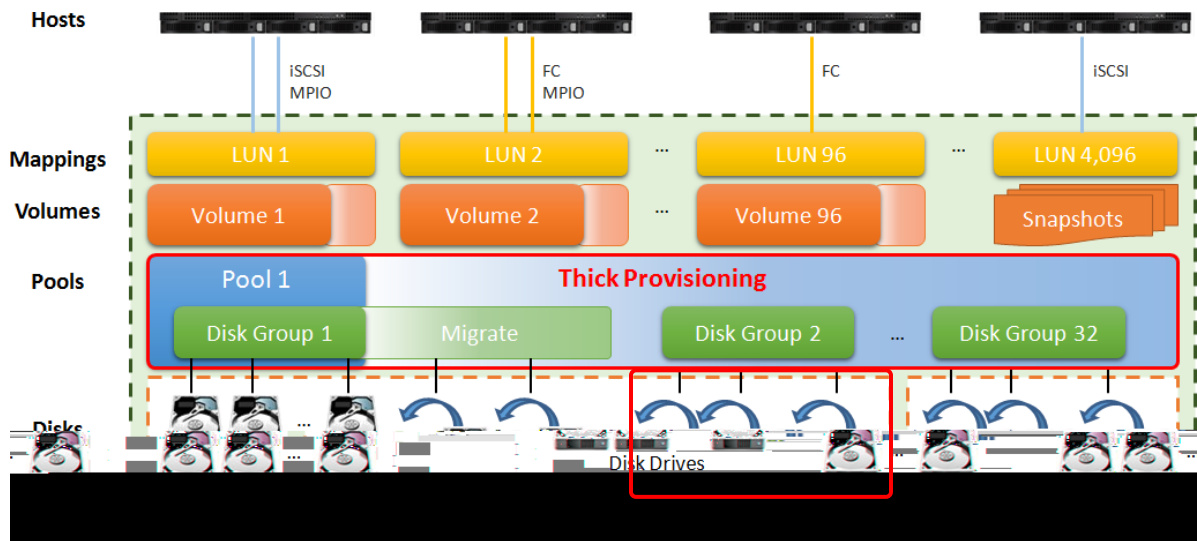

Figure 8-32 Add a Disk Group in a Thick Provisioning Pool

Here is an example of adding a disk group into a thick provisioning pool with 2 disks configured in RAID 1.

1. Select a pool, click ▼ -> **Add Disk Group** to add a disk group in a thick provisioning pool.

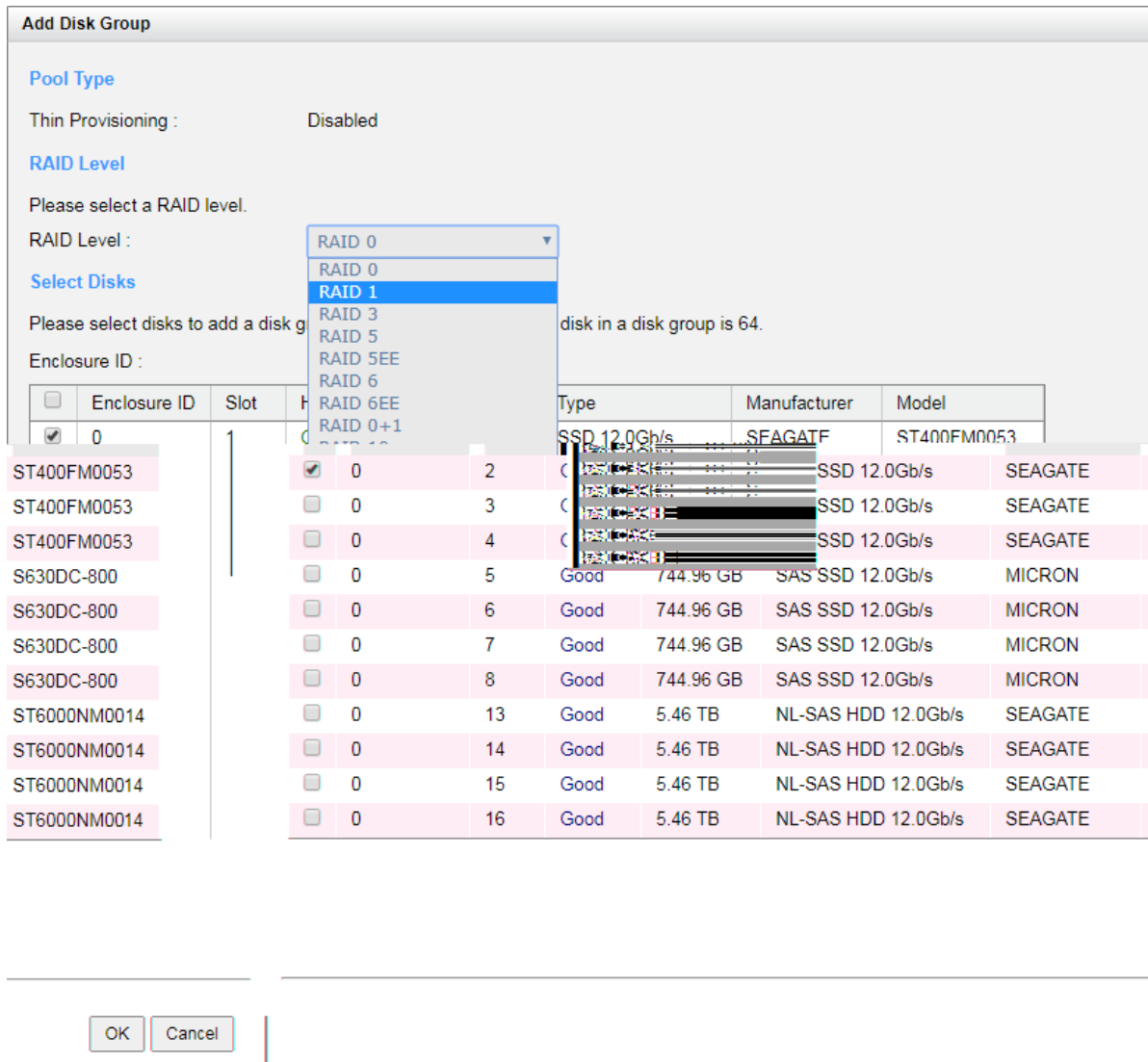

Figure 8-33 Add a Disk Group to a Thick Provisioning Pool

2. Select a **RAID Level** from the drop-down list and also select a **Quantity of Subgroups** if the combination RAID level is selected.
3. Select disks to add into a disk group. The maximum quantity of disk in a disk group is 64. Select an **Enclosure ID** from the drop-down list to select disks from expansion enclosures.
4. Click the **OK** button to add a disk group into the pool.

Pool Name	Status	Health	Total	Free	Available	Thin Provisioning	Encryption	Volumes	Current Controller
Pool-1	Disabled	Disabled	4.00 TB	0	0	Controller 1		Pool-1	Online Good 4.00 T

No.	Status	Health	Total
1	Online	Good	3.27 TB
2	Online	Good	744.00 GB

Enclosure ID	Slot	Status	Health	Capa
0	1	Online	Good	372.3
0	2	Online	Good	372.3

Free	RAID	Disks Used	RAID EE Spares
3.27 TB	RAID 5	4	N/A
744.00 GB	RAID 0	2	N/A

Capacity	Disk Type	Manufacturer	Model
6 GB	SAS SSD 12.0Gb/s	SEAGATE	ST400FM0053
6 GB	SAS SSD 12.0Gb/s	SEAGATE	ST400FM0053

Figure 8-34 A Disk Group is Added

5. A disk group has been added into the pool.



TIP:

If auto tiering license is enabled, the thick provisioning pool without disk group of mixed disk type can be transferred to the auto tiering pool by **Add Disk Group** option. Please refer to the chapter 11.6.1, [Transfer from Thick Provisioning Pool to Auto Tiering](#) section.

8.5. Configuring Volumes

Select the **Volumes** function submenu to create, modify, delete, or view the status of the volumes. The same as pool, we will describe thick provisioning volume in the following section, and keep thin provisioning in the [Thin Provisioning](#) chapter and auto tiering in the [Auto Tiering](#) chapter.

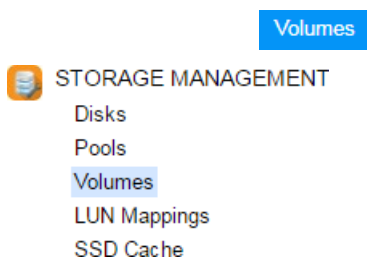

Figure 8-35 Pools Function Submenu

8.5.1. Create a Volume

Here is an example of creating a volume in thick provisioning Pool.

1. Select the **Volumes** function submenu, click the **Create Volume** button.

The screenshot shows a 'Create Volume' window with the following fields:

- Volume Name:** Vn1-1
- Pool Name:** Pool-1 (Available: 2607 GB)
- Capacity:** 100 GB
- Volume Type:** RAID Volume

At the bottom right, there are 'Next' and 'Cancel' buttons.

Figure 8-36 Create a Volume in Thick Provisioning Pool Step 1

2. Enter a **Volume Name** for the pool. The maximum length of the volume name is 32 characters. Valid characters are [A~Z | a~z | 0~9 | -_<>].
3. Select a **Pool Name** from the drop-down list. It will also display the available capacity of the pool.
4. Enter required **Capacity**. The unit can be selected from the drop-down list.
5. Select the **Volume Type**. The options are **RAID Volume** (for general RAID usage) and **Backup Volume** (for the target volume of local clone or remote replication).
6. Click the **Next** button to continue.

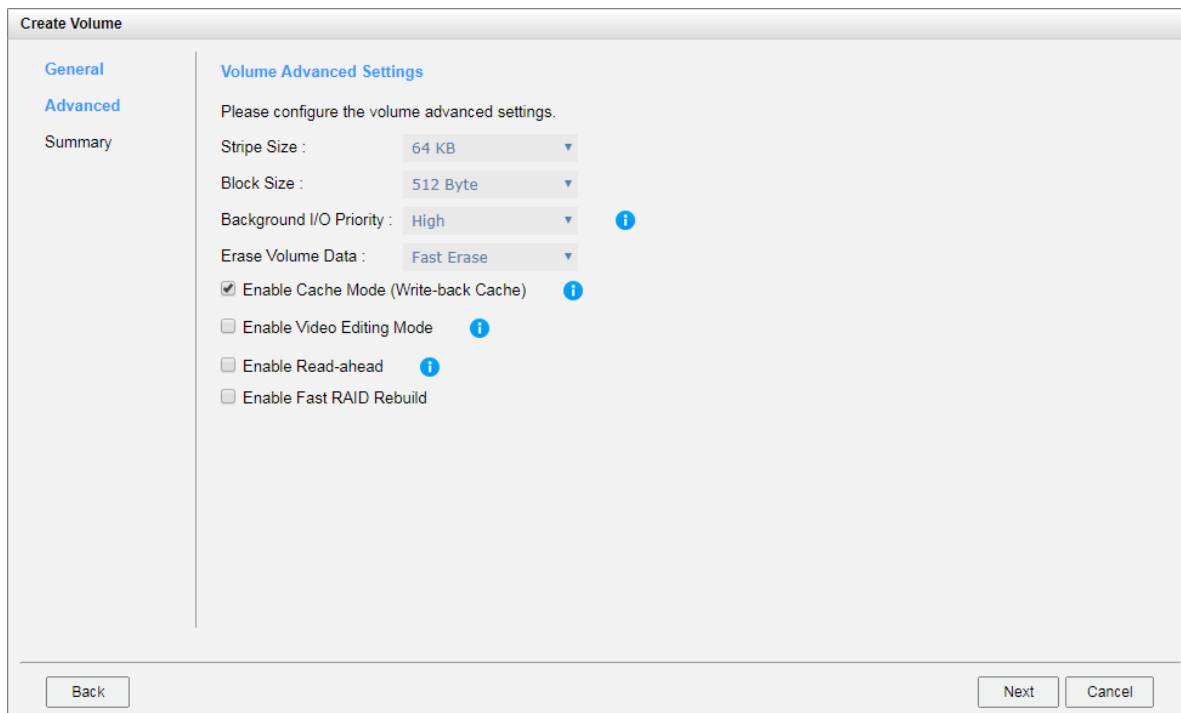

Figure 8-37 Create a Volume in Thick Provisioning Pool Step 2

7. Volume advanced settings can also be configured optionally in this step:

Stripe Size: The options are 64KB to 1,024KB.

Block Size: The options are 512Bytes to 4,096 Bytes.

Background I/O Priority: The options are High, Medium, and Low. It will influence volume initialization, rebuild, and migration.

Erase Volume Data: This option is available when the pool is thick provisioning. This option will wipe out old data in volume to prevent that OS recognizes the old partition. The options are Do Not Erase, Fast Erase which will erase the first 1GB data of the volume, or Full Disk which will erase entire volume.

Enable Cache Mode (Write-back Cache): Check to enable cache mode function of volume. Write back optimizes the system speed but comes with the risk where the data may be inconsistent between cache and disks in one short time interval.

Enable Video Editing Mode: Check to enable video editing mode function. It is optimized for video editing usage. Please enable it when your application is in video editing environment. This option provides a more stable performance figure without high and low peaks but slower in average.

Enable Read-ahead: Check to enable the read ahead function of volume. The system will discern what data will be needed next based on what was just retrieved from

disk and then preload this data into the disk's buffer. This feature will improve performance when the data being retrieved is sequential.

Enable Fast RAID Rebuild: This option is available when the pool is created in protection RAID level (e.g., RAID 1, 3, 5

<< first < prev 1 next > last >>

	Volume Name	Status	Health	Capacity	Volume Type	SSD Cache	Snapshot Space	Snapshots	Clone	Write	Pool Name
▼	Vol-1	Initializing (8%)	Optimal	100.00 GB	RAID Volume	Disabled	0 MB / 0 MB	0	N/A	WB	Pool-1

<< first < prev 1 next > last >>

Create Volume Local Clone Options

Figure 8-39 A Volume in Thick Provisioning Pool is Created and Initializing

11. A volume has been created. If necessary, click **Create Volume** button to create another.



INFORMATION:

SANOS supports instant RAID volume availability. The volume can be used immediately when it is initializing or rebuilding.



TIP:

If the pool contains some disk drives of 4Kn type, it is not available to set 512, 1024, or 2048 block size. When the case happens, it will pop up a warning message and suggest changing the block size to 4096.

8.5.2. List Volumes

Select one of the volumes; it will display the related LUN Mappings if the volume is mapped. The volume properties can be configured by clicking the functions button ▼ to the left side of the specific volume.

<< first < prev 1 next > last >>

	Volume Name	Status	Health	Capacity	Volume Type	SSD Cache	Snapshot Space	Snapshots	Clone	Write	Pool Name
▼	Vol-1	Online	Optimal	100.00 GB	RAID Volume	Disabled	0 MB / 0 MB	0	N/A	WB	Pool-1

<< first < prev 1 next > last >>

LUN Mappings

Allowed Hosts	Target	LUN	Permission	Sessions
*	0	0	Read-write	0

Create Volume Local Clone Options

Figure 8-40 List Volumes

This table shows the column descriptions.

Table 8-12 Volume Column Descriptions

Column Name	Description
Volume Name	The volume name.
Status	<p>The status of the volume:</p> <ul style="list-style-type: none"> • Online: The volume is online. • Offline: The volume is offline. • Erasing: The volume is being erased if the Erase Volume Data option is set. • Initiating: The volume is being initialized. • Rebuilding: The volume is being rebuilt. • Migrating: The volume is being migrated. • Rollback: The volume is being rolled back. • Parity Checking: The volume is being parity check. • Relocating: The volume is being relocated. • EE Rebuilding: The volume is being RAID EE rebuilt.
Health	<p>The health of the volume:</p> <ul style="list-style-type: none"> • Optimal: the volume is working well and there is no failed disk in the RG. • Failed: the pool disk of the volume has single or multiple failed disks than its RAID level can recover from data loss. • Degraded: At least one disk from the pool of the volume has failed or plugged out. • Non-optimal: the volume has experienced recoverable read errors. After passing parity check, the health will become Optimal.
Capacity	Total capacity of the volume.
Volume Type	<p>The type of the volume:</p> <ul style="list-style-type: none"> • RAID Volume. • Backup Volume.
SSD Cache	<p>The status of the SSD cache:</p> <ul style="list-style-type: none"> • Enabled: The volume is enabled SSD cache. • Disabled: The volume is disabled SSD cache.
Snapshot space	Used snapshot space / Total snapshot space. The first capacity is current used snapshot space, and the second capacity is reserved total snapshot space.
Snapshots	The quantity of the snapshot in the volume.
Clone	The target name of the clone volume.
Write	The access right of the volume:

	<ul style="list-style-type: none"> • WT: Write Through. • WB: Write Back. • RO: Read Only.
Pool Name	Which pool the volume belongs to.

8.5.3. Operations on Volumes

The options are available in this tab:

Setup Local Cloning Options

Click the **Local Cloning Options** button to set the clone options. For more information, please refer to the chapter 12.2.4, [Local Cloning Options](#) section in the Data Backup chapter.

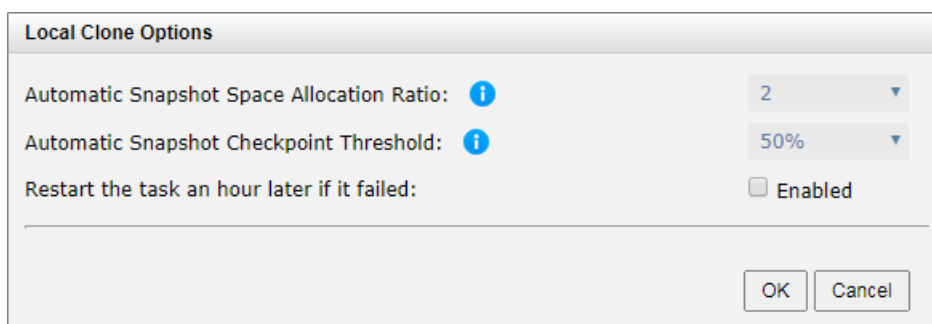
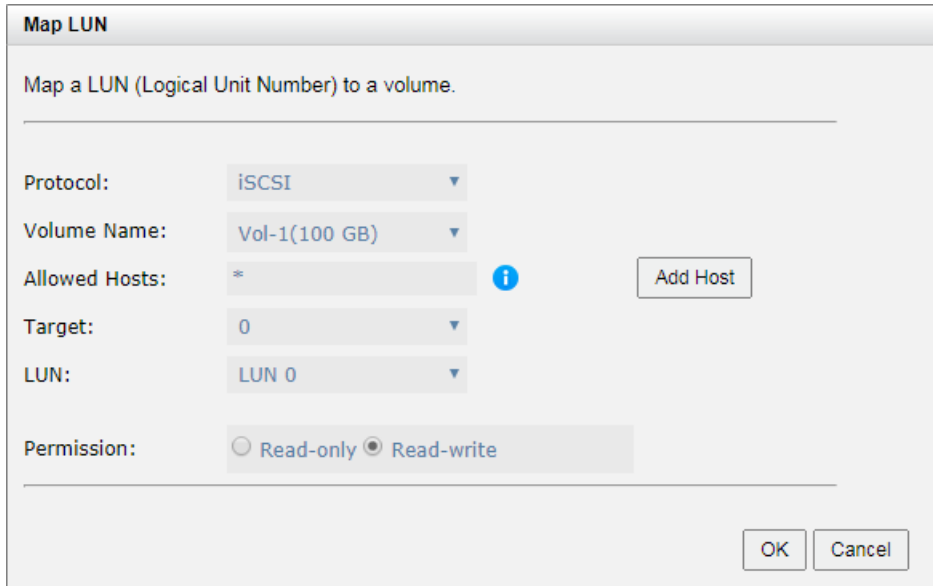

Figure 8-41 Local Cloning Options

LUN Mapping Operations

Click ▼ -> **Map LUN** to map a logical unit number to the volume. For more information about map and unmap LUN, please refer to the chapter 8.6, [Configure LUN Mappings](#) section.



Map LUN

Map a LUN (Logical Unit Number) to a volume.

Protocol:

Volume Name:

Allowed Hosts: ⓘ

Target:

LUN:

Permission: Read-only Read-write

Figure 8-42 Map a LUN of iSCSI Connectivity

Click ▼ -> **Unmap LUNs** to unmap logical unit numbers from the volume.

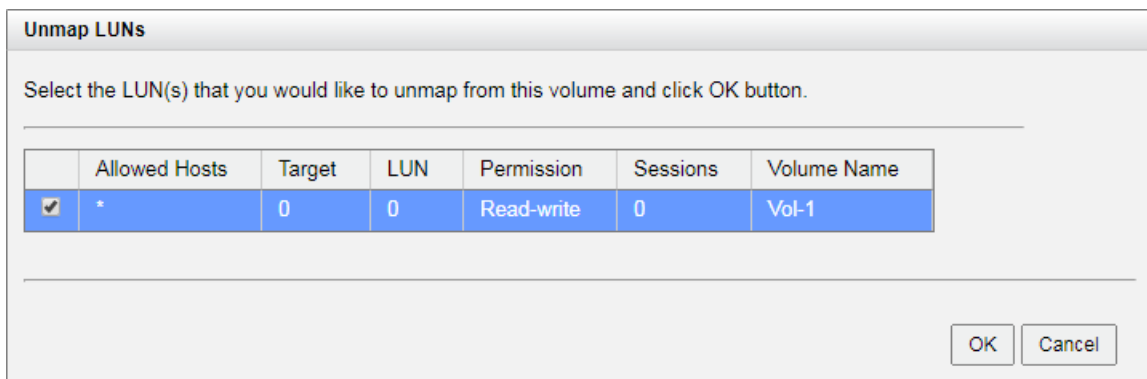

Unmap LUNs

Select the LUN(s) that you would like to unmap from this volume and click OK button.

	Allowed Hosts	Target	LUN	Permission	Sessions	Volume Name
<input checked="" type="checkbox"/>	*	0	0	Read-write	0	Vol-1

Figure 8-43 Unmap LUNs

Snapshot Operations

Click ▼ -> **Set Snapshot Space** to set snapshot space for preparing to take snapshots. For more information about snapshot, please refer to the chapter 12.1, [Managing Snapshots](#) section in the Data Backup chapter.

Set Snapshot Space

Volume Name: Vol-1

Capacity: 100 GB Available: 2507GB
Minimum: 6GB

Free Capacity: 2507GB

OK Cancel

Figure 8-44 Set Snapshot Space

Click ▼ -> **Take Snapshot** to take a snapshot of the volume.

Click ▼ -> **Schedule Snapshots** to set the snapshots by schedule.

Click ▼ -> **List Snapshots** to list all snapshots of the volume.

Click ▼ -> **Cleanup Snapshots** to clean all snapshots of the volume and release the snapshot space.

Local Clone Operations

Click ▼ -> **Create Local Clone** to set the target volume for clone. For more information about local clone, please refer to the chapter 12.2, [Managing Local Clones](#) section in the Data Backup chapter.

Create Local Clone

<< first < prev 1 next > last >>

	Volume Name	Capacity	Status	Health	Pool Name
<input checked="" type="radio"/>	Target-Vol-2	110.00 GB	Online	Optimal	Pool-1

<< first < prev 1 next > last >>

OK Cancel

Figure 8-45 Create Local Clone

Click ▼ -> **Clear Clone** to clear the clone.

Click ▼ -> **Start Clone** to start the clone.

Click ▼ -> **Stop Clone** to stop the clone.

Click ▼ -> **Schedule Clone** to set the clone function by schedule.

Click ▼ -> **Change Replication Options** to change the clone to Replication relationship. For more information about remote replication, please refer to the chapter 12.3, [Managing Remote Replications](#) section in the Data Backup chapter.

SSD Cache Options

Click ▼ -> **Enable SSD Cache** to enable SSD cache for the volume. For more information about SSD cache, please refer to the chapter 10, [SSD Cache](#) chapter.

Click ▼ -> **Disable SSD Cache** to disable SSD cache for the volume.

Change Volume Properties

Click ▼ -> **Change Volume Properties** to change the volume properties of the volume.

Figure 8-46 Change Volume Properties

Verify Parity of the Volume

Click ▼ -> **Verify Parity** to execute parity check for the volume which is created by the pool in parity RAID level (e.g., RAID 3, 5, 6, 30, 50, and 60). This volume can either be verified and repaired or only verified for data inconsistencies. This process usually takes a long time to complete.

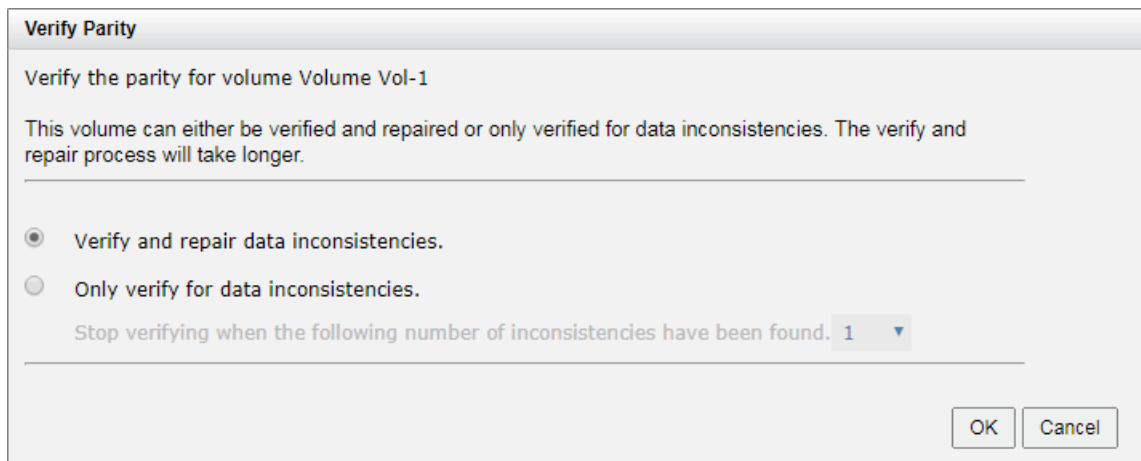

Figure 8-47 Verify Parity

Extend Volume Capacity

Click ▼ -> **Extend Volume** to extend the volume capacity. For more information, please refer to the chapter 8.5.4, [Extend Volume Capacity](#) section.

Delete Volume

Click ▼ -> **Delete** to delete the volume. The related LUN mappings will also be deleted.

More Information of the Volume

Click ▼ -> **More Information** to show the detail information of the volume.

8.5.4. Extend Volume Capacity

Extend Volume function extends the capacity of the volume if there is enough free space.

Here's how to extend a volume:

1. Select the **Volumes** function submenu, select a volume, and then click ▼ -> **Extend Volume**.
2. Change the volume capacity. The capacity must be larger than the current, and then click the **OK** button to start extension.

Figure 8-48 Extend Volume Capacity

3. If the volume needs initialization, it will display the status **Initiating** and the complete percentage of initialization in **Status**.
4. It's done when the complete percentage reaches 100%.



INFORMATION:

The extension capacity must be larger than the current capacity.



TIP:

Extension cannot be executed during rebuilding or migration.

8.5.5. Fast RAID Rebuild

When executing rebuild, the Fast RAID Rebuild feature skips any partition of the volume where no write changes have occurred, it will focus only on the parts that have changed. This mechanism may reduce the amount of time needed for the rebuild task. It also reduces the risk of RAID failure cause of reducing the time required for the RAID status from degraded mode to healthy. At the same time, it frees up CPU resources more quickly to be available for other I/O and demands. For more information, please refer to the [Fast Rebuild White Paper](#).

Enable Fast RAID Rebuild

Here is an example of enabling the Fast RAID Rebuild function when creating a volume.

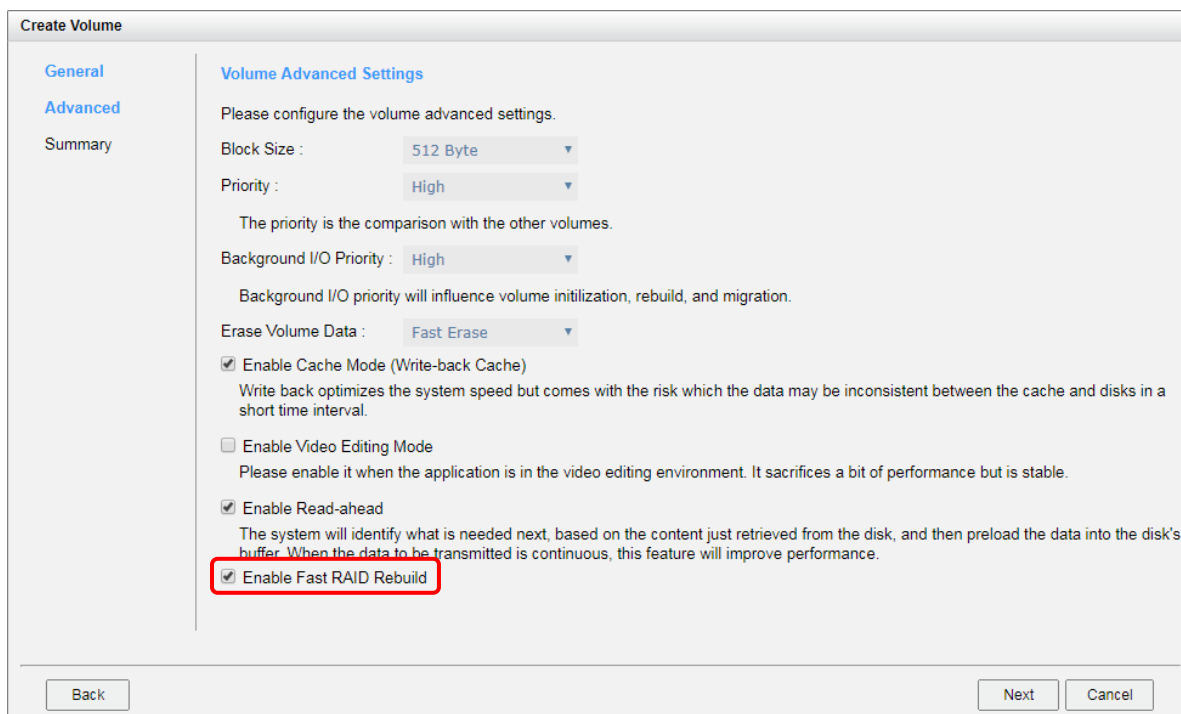

Figure 8-49 Enable Fast RAID Rebuild When Creating a Volume

Fast RAID Rebuild Notices

Here are some notices about Fast RAID Rebuild.

- Only a thick provisioning pool supports enabling/disabling this feature, a thin provisioning pool has included this feature and set as enabled by default.
- When a rebuild occurs in a fast rebuild volume, clean partitions are not rebuilt since there are no data saved there. Though clean partitions are never rebuilt, their health status is good.
- If all partitions of the fast rebuild volume are clean, then no rebuild would happen and no event would be sent.
- The RAID stacks could not use optimize algorithm to compute parities of a partition which is not rebuilt. Thus, the performance of random write in a clean partition would be worse.



CAUTION:

Disabling Fast RAID Rebuild function is recommended when the access pattern to the volume is random write.

8.6. Configure LUN Mappings

Select the **LUN Mappings** function submenu to map, unmap or view the status of LUN (Logical Unit Number) for each volume.



Figure 8-50 Pools Function Submenu

8.6.1. Map a LUN of iSCSI Connectivity

Here's an example of mapping a LUN of iSCSI connectivity.

1. Select the **LUN Mappings** function submenu, click the **Map LUN** button.

Map LUN

Map a LUN (Logical Unit Number) to a volume.

Protocol: iSCSI ▼

Volume Name: Vol-1(100 GB) ▼

Allowed Hosts: * ⓘ Add Host

Target: 0 ▼

LUN: LUN 0 ▼

Permission: Read-only Read-write

OK Cancel

Figure 8-51 Map a LUN of iSCSI Connectivity

2. Select the **Protocol** as iSCSI.
3. Select a **Volume** from the drop-down list.
4. Enter the **Allowed Hosts** with semicolons (;) or click the **Add Host** button to add one by one. Fill-in wildcard (*) for access by all hosts.
5. Select a **Target** from the drop-down list.
6. Select a **LUN** from the drop-down list.
7. Select a **Permission** level, normally set it as **Read-write**.
8. Click the **OK** button to map a LUN.

The matching rules of access control are followed from created time of the LUNs. The earlier created LUN is prior to the matching rules. For example: there are two LUN rules which are set to the same volume:

1. Allow Hosts sets *, LUN is *LUN 0*
2. Allow Hosts sets *iqn.host1*, LUN is *LUN 1*

The host *iqn.host2* can login successfully because it matches the rule 1.

Wildcard * and ? are allowed in this field.

- Wildcard * can replace any word.
- Wildcard ?: can replace only one character.

For example:

- *iqn.host?* -> *iqn.host1* and *iqn.host2* are accepted.
- *iqn.host** -> *iqn.host1* and *iqn.host12345* are accepted.

This field cannot accept comma, so *iqn.host1, iqn.host2* stands a long string, not two *iqns*.

8.6.2. Map a LUN of Fibre Channel Connectivity

Here's an example of mapping a LUN of fibre channel connectivity.

1. Select the **LUN Mappings** function submenu, click the **Map LUN** button.

Map LUN

Map a LUN (Logical Unit Number) to a volume.

Protocol: FCP

Volume Name: Vol-1(100 GB)

Allowed Hosts: * ⓘ Add Host

Target: 2000001378FF8800

LUN: LUN 0

Permission: Read-only Read-write

Link Reset: Yes No

OK Cancel

Figure 8-52 Map a LUN of FC Connectivity

2. Select the **Protocol** as FCP (Fibre Channel Protocol).
3. Select a **Volume** from the drop-down list.
4. Enter the **Allowed Hosts** with semicolons (;) or click the **Add Host** button to add one by one. Fill-in wildcard (*) for access by all hosts.
5. Select a **Target** from the drop-down list.
6. Select a **LUN** from the drop-down list.
7. Select a **Permission** level. Normally set it as **Read-write**.
8. Set **Link Reset** to **Yes** if the fibre channel needs to reset when it is connected.
9. Click the **OK** button to map a LUN.

8.6.3. List LUN Mappings

List all LUN mappings in this page. The LUN properties can be configured by clicking the functions button ▼ to the left side of the specific LUN.

	Allowed Hosts	Target	LUN	Permission	Sessions	Volume Name
▼	*	0	0	Read-write	0	Vol-1

Map LUN

Figure 8-53 List LUN Mappings

This table shows the column descriptions.

Table 8-13 LUN Mapping Column Descriptions

Column Name	Description
Allowed Hosts	The target of FC / iSCSI for access control or a wildcard (*) for access by all hosts.
Target	The target number.
LUN	The logical unit number which is mapped.
Permission	The permission level: <ul style="list-style-type: none"> • Read-write • Read-only
Sessions	The quantity of the active iSCSI connection linked to the logical unit. Show N/A if the protocol is FCP.
Volume Name	The name of the volume assigned to this LUN.

8.6.4. Operations on LUN Mappings

The options are available on this tab:

Unmap a LUN

Click ▼ -> **Unmap LUN** to unmap a logical unit number from the volume.

8.7. Connect by Host Initiator

After map a LUN to a volume, the host can connect the volume by initiator program. We provide some documents of host connections for reference. The documents are available at the website:

- [How to Configure iSCSI Initiator in Microsoft Windows](#)
- [How to Configure iSCSI Initiator in ESXi 6.x](#)
- [Implement iSCSI Multipath in RHEL 6.5](#)

8.8. Disk Roaming

Disks can be re-sequenced in the same system or move all member disks in the same pool from system-1 to system-2. This is called disk roaming. System can execute disk roaming online. Please follow these steps.

1. Select the **Pools** function submenu, selects a pool. And then click ▼ -> **Deactivate**.
2. Click the **OK** button to apply. The Status changes to **Offline**.
3. Move all member disks of the pool to another system.
4. In the **Pools** function submenu, select the pool. And then click ▼ -> **Activate**.
5. Click the **OK** button to apply. The Status changes to **Online**.

Disk roaming has some constraints as described in the following.

1. Check the firmware version of two systems first. It is better for both systems to have the same firmware version or the firmware version of the system-2 is newer.
2. All physical disks of the pool should be moved from system-1 to system-2 together. The configuration of both pool and volume will be kept but LUN configuration will be cleared in order to avoid conflict with the current setting of the system-2.



CAUTION:

XCubeSAN series does NOT support disk roaming from AegisSAN LX, AegisSAN Q500, and AegisSAN V100.

9. Thin Provisioning

This chapter describes an overview and operations of thin provisioning.

9.1. Overview

Nowadays, thin provisioning is a hot topic people talk about in IT management and storage industry circles. To contrast thin provisioning, it naturally comes to mind with the opposite term – thick or fat provisioning, which is the traditional way IT administrators allocate storage space to each logical volume that is used by an application or a group of users. When it comes to the point of deciding how much space a logical volume requires for three years or for the lifetime of an application, it's really hard to make the prediction correctly and precisely. To avoid the complexity of adding more space to the volumes frequently, IT administrators might as well allocate more storage space to each logical volume than it needs in the beginning. This is why it's called thick or fat provisioning. Usually it turns out that a lot of free disk space is sitting around idle. This stranded capacity is wasted, which equals to waste of investment in drives, energy usage, and general inefficiency. Various studies indicate that as much as 75% of the storage capacity in small and medium enterprises or large data centers is allocated but unused. And this is where thin provisioning kicks in.

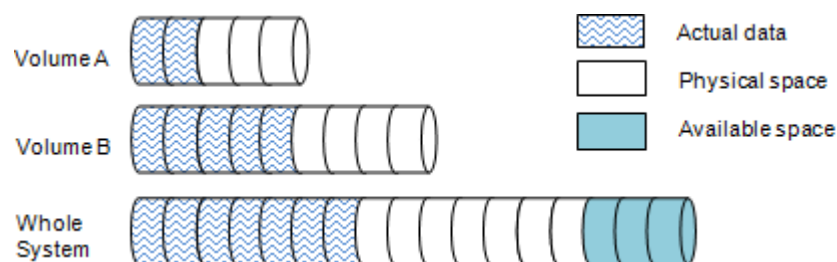

Figure 9-1 Traditional Thick Provisioning

Thin provisioning sometimes is known as just-in-time capacity or over allocation. As the term explains itself, it provides storage space dynamically on demand. Thin provisioning presents more storage space to the hosts or servers connecting to the storage system than is actually physically available on the storage system. To put it in another way, thin provisioning allocates storage space that may or may not exist. The whole idea is actually another way of virtualization. Virtualization is always about a logical pool of physical assets

and provides better utilization over those assets. Here the virtualization mechanism behind thin provisioning is storage pool. The capacity of the storage pool is shared by all volumes. When write requests come in, the space will be drawn dynamically from this storage pool to meet the needs.

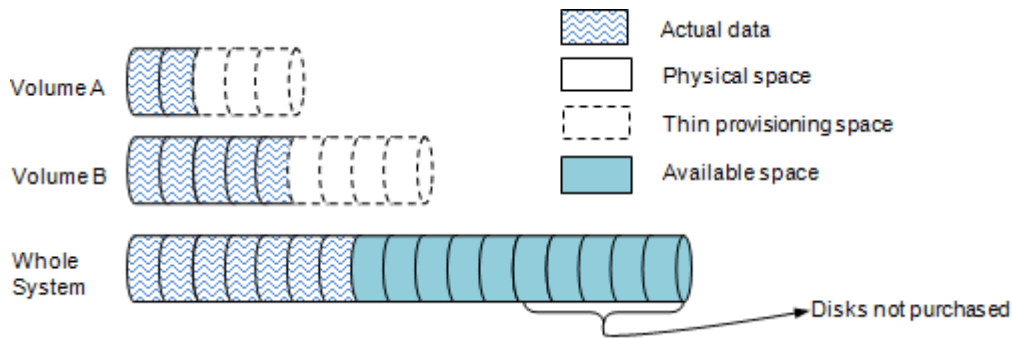

Figure 9-2 Thin Provisioning

9.1.1. Thick Provisioning vs. Thin Provisioning

The efficiency of thin or thick provisioning is a function of the use case, not of the technology. Thick provisioning is typically more efficient when the amount of resource used very closely approximates to the amount of resource allocated. Thin provisioning offers more efficiency where the amount of resource used is much smaller than allocated, so that the benefit of providing only the resource needed exceeds the cost of the virtualization technology used.

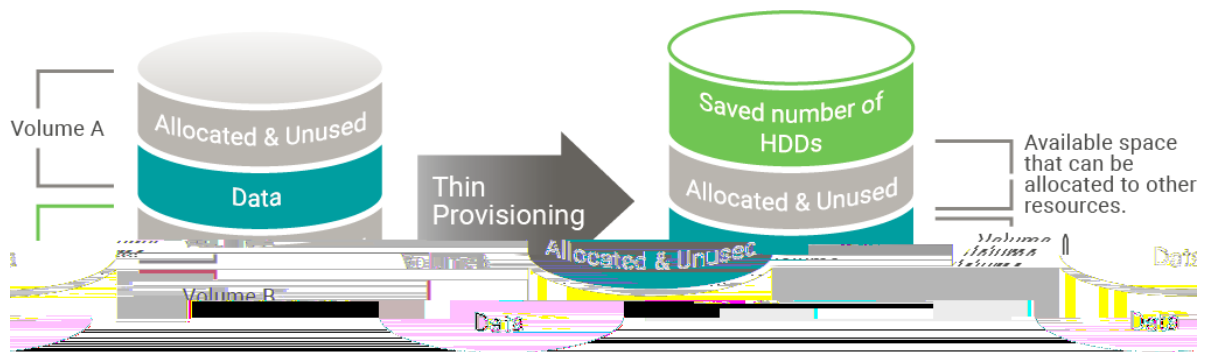

Figure 9-3 Benefits of Thin Provisioning

9.2. Theory of Operation

Thin provisioning, in a shared-storage environment, provides a method for optimizing utilization of available storage. It relies on on-demand allocation of blocks of data versus the traditional method of allocating all the blocks up front. This methodology eliminates almost all whitespace which helps avoid poor utilization rates.

With thin provisioning, storage capacity utilization efficiency can be automatically driven up towards 100% with very little administrative overhead. Organizations can purchase less storage capacity up front, defer storage capacity upgrades in line with actual business growth, and save the operating costs (electricity and floor space) associated with keeping unused disk capacity spinning.

9.2.1. Thin Provisioning Architecture

A thin provisioning pool is a collection of disk groups which contain disk drives and made up a RAID. Similarly, a storage pool is grouped to provide capacity for volumes. Volumes are then allocated out of the storage pool and are mapped to LUN which can be accessed by a host system. The following is the storage architecture of a thin provisioning pool.

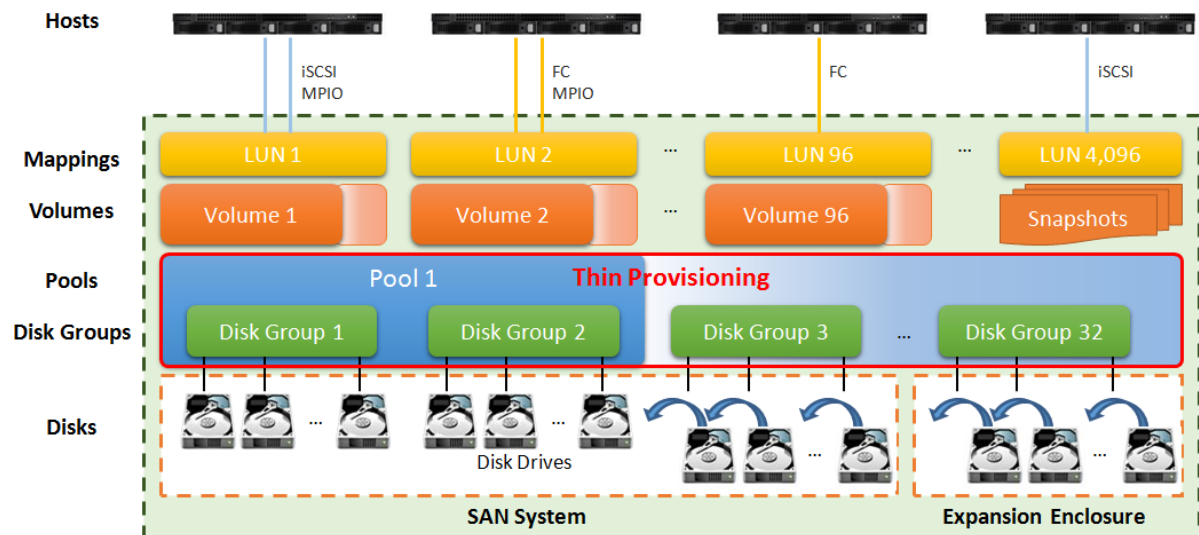

Figure 9-4 Storage Architecture of Thin Provisioning Pool

Disk groups which contain disk drives can be added to a thin provisioning pool at any time to increase the capacity of the pool. A thin provisioning pool can have up to 32 disk groups with each disk group containing up to 64 disk drives. And the maximum disk drive quantity

in a pool is 256. The maximum addressable capacity of each disk group is 64TB. So the maximum capacity in a system is 256TB. For more information about pool operation, please refer to the chapter 9.3, [Configuring Thin Provisioning Pools](#) section.

Table 9-1 Thin Provisioning Pool Parameters

Item	Value
Maximum disk group quantity in a pool	32
Maximum disk drive quantity in a disk group (include dedicated spares)	64
Maximum RAID EE spare quantity in a disk group	8
Maximum disk drive quantity in a pool (include dedicated spares)	256
Maximum pool quantity per system	64
Maximum dedicated spare quantity in a pool	8
Maximum addressable capacity of a disk group	64TB
Maximum addressable capacity of a thin provisioning pool	256TB
Maximum addressable capacity of total thin provisioning pools (include auto tiering pools)	1,024TB
Provisioning granularity	1GB

9.2.2. Space Reclamation

Previously allocated, but currently unused volume space can be reclaimed in disk pools after all data within a granularity have been deleted from volumes by hosts. Data must be permanently deleted to be considered as unused space. The unused space is returned to the pool.

Similar to the manual operation of reclaiming volume space is the auto-reclamation process, which is the continual process of automatically reclaiming spaces that are "not in use" or "zeroed-out" and returning them to the pool without user intervention. The auto-reclamation process has some benefits over running the manual operation. For more information about the operation, refer to the chapter 9.4.1, [Create a Volume in a Thin Provisioning Pool](#) section.

9.2.3. Thin Provisioning Policies

Because thin provisioning is just-in-time capacity or over allocation, thin provisioning policies have been designed to warn in advance. There are 2 levels of threshold percentage and the available values defined as the following table.

Table 9-2 Thin Provisioning Policies and Available Values

No.	Action	Threshold	Default Threshold
1	Reclaim Space	85% ~ 89%	85%
2	Read-only Volume	95% ~ 99%	95%

You can configure a threshold percentage based on pool capacity. Take the default threshold as an example. When the used capacity of the thin provisioning pool reaches 85%, in addition to the system issued an event with warning level, but also began to implement space reclamation. After reaching 95%, the volumes will be set to read-only to avoid data loss.

For more information about the operation, refer to the chapter 9.3.3, [Operations on Thin Provisioning Pools](#) section.



CAUTION:

Please always watch the system logs of thin provisioning pool. If the used capacity of the thin provisioning pool reaches 95%, the system will force to set all volumes in the pool to be read-only to avoid data loss. So the host cannot write data at this time. You have to expand the pool capacity, and then configure the **Volume Type** back to **RAID Volume** to resolve the issue. For more information about the operation, refer to the chapter 8.5.3, [Operations on Volumes](#) section.

9.3. Configure Thin Provisioning Pools

This section will describe the operations of configuring thin provisioning pool.

Pools

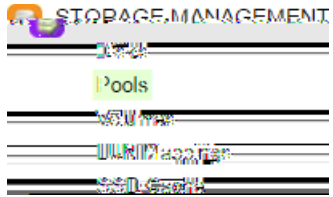

Figure 9-5 Pools Function Submenu

9.3.1. Create a Thin Provisioning Pool

Here is an example of creating a thin provisioning pool with 4 disks configured in RAID 5. At the first time of creating a thin provisioning pool, it contains a disk group and the maximum quantity of disk in a disk group is 64.

1. Select the **Pools** function submenu, click the **Create Pool** button. It will scan available disks first.



TIP:

It may take 20 ~ 30 seconds to scan disks if your system has more than 200 disk drives. Please wait patiently.

Create Pool

General

- Disk Selection
- RAID Configuration
- Disk Properties
- Summary

Pool Type

Please select a pool type.

Thick Provisioning
 Thin Provisioning

Pool Properties

Please enter a pool name and select preferred controller setting.

Pool Name : ⓘ

Preferred Controller : ▾

The I/O resources will be managed by the preferred controller which you specified.

SED Pool

Enable SED Pool

Enabling SED pool will use the secure SEDs to create a pool. Intermixing SEDs and non-SEDs are not supported in a pool.

Next Cancel

Figure 9-6 Create a Thin Provisioning Pool Step 1

2. Select the **Pool Type** as Thin Provisioning.
3. Enter a **Pool Name** for the pool. The maximum length of the pool name is 16 characters. Valid characters are [A~Z | a~z | 0~9 | -_<>].
4. Select a **Preferred Controller** from the drop-down list. The backend I/O resources in this pool will be processed by the preferred controller which you specified. This option is available when dual controllers are installed.
5. Check the **Enable SED Pool** checkbox. Enabling SED pool will use the secure SEDs to create a pool. Intermixing SEDs and non-SEDs are not supported in a pool.
6. Click the **Next** button to continue.

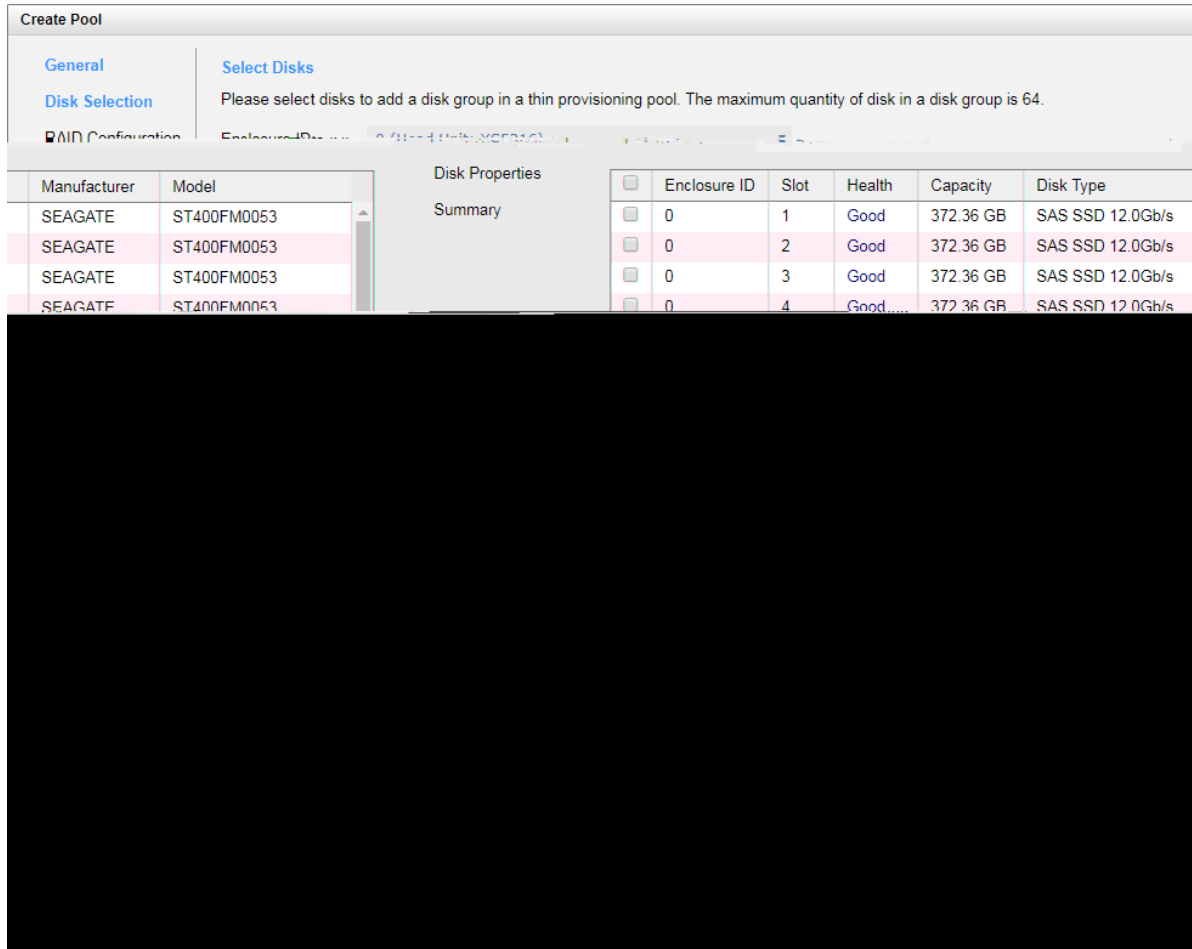

Figure 9-7 Create a Thin Provisioning Pool Step 2

7. Please select disks for pool. The maximum quantity of disk in a disk group is 64. Select an **Enclosure ID** from the drop-down list to select disks from expansion enclosures.
8. Click the **Next** button to continue.

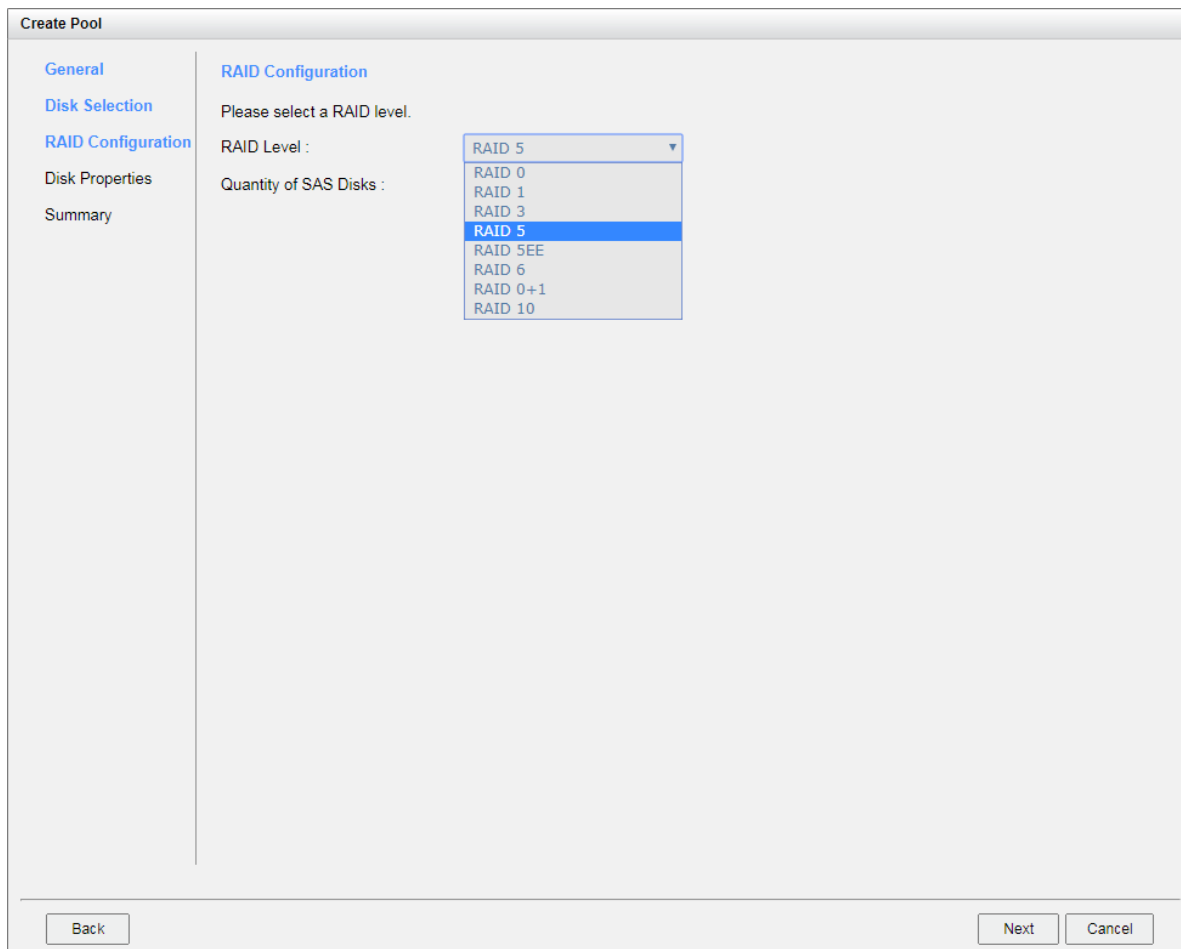

Figure 9-8 Create a Thin Provisioning Pool Step 3

9. Select a **RAID Level** from the drop-down list which lists available RAID level only according to the disk selection. And also select a **Quantity of Subgroups** if the combination RAID level is selected.
10. Click the **Next** button to continue.

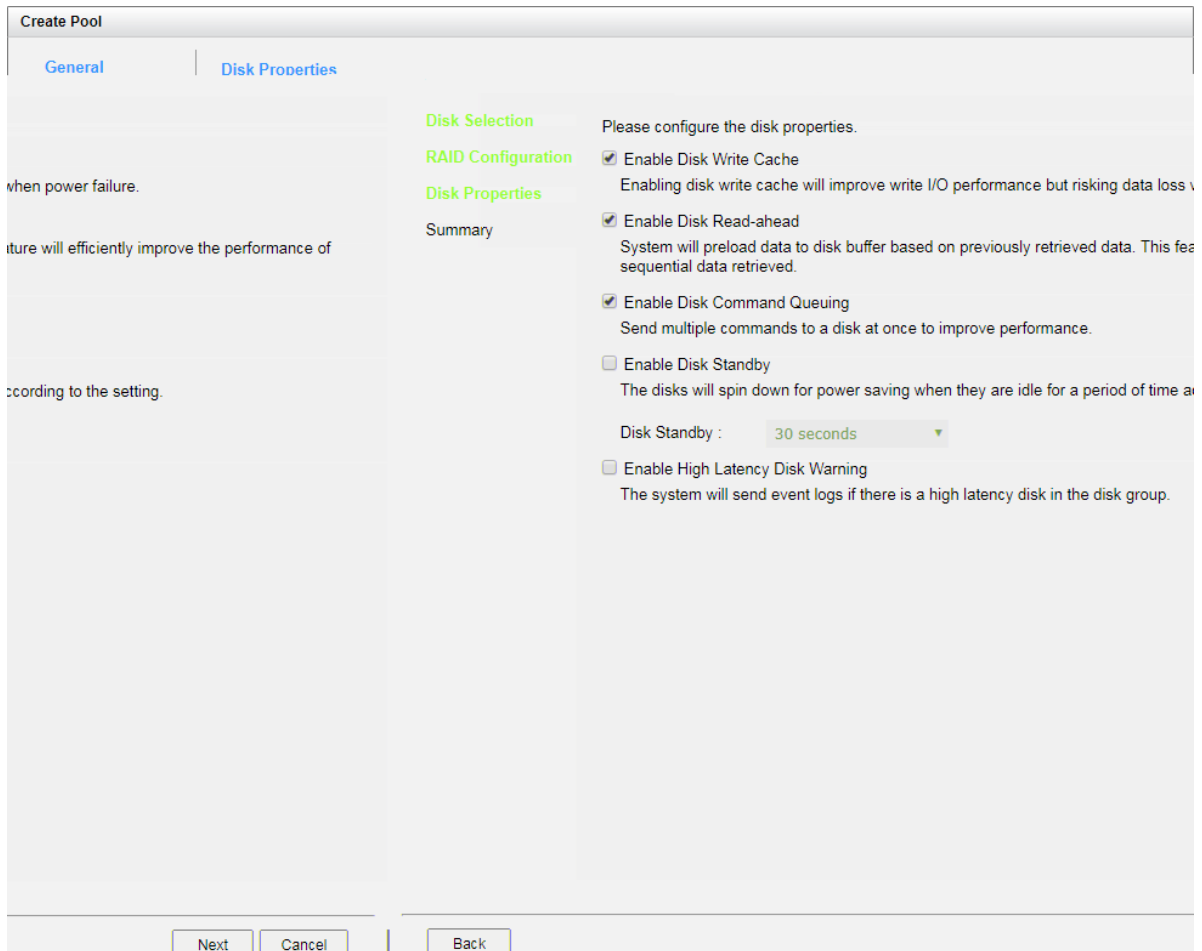

Figure 9-9 Create a Thin Provisioning Pool Step 4

11. Disk properties can also be configured optionally in this step:

Enable Disk Write Cache: Check to enable the write cache option of disks. Enabling disk write cache will improve write I/O performance but have a risk of losing data when power failure.

Enable Disk Read-ahead: Check to enable the read-ahead function of disks. System will preload data to disk buffer based on previously retrieved data. This feature will efficiently improve the performance of sequential data retrieved.

Enable Disk Command Queuing: Check to enable the command queue function of disks. Send multiple commands to a disk at once to improve performance.

Enable Disk Standby: Check to enable the auto spin down function of disks. The disks will be spun down for power saving when they are idle for the period of time specified.

Enable High Latency Disk Warning: Check to enable the high latency disk warning function in a disk group. When a disk drive is abnormal with high latency, the system

will send event logs to notify IT administrators in advance to avoid affecting overall performance.

12. Click the **Next** button to continue.

Create Pool

General

- Disk Selection
- RAID Configuration
- Disk Properties
- Summary

Pool Properties

Pool Type : Thin Provisioning

Pool Name : Pool-2

Preferred Controller : Controller 1

RAID Configuration

RAID Level : RAID 5

Quantity of SAS Disks : 4

Disk Properties

Disk Write Cache : Enabled

Disk Read-ahead : Enabled

Disk Command Queuing : Enabled

Disk Standby : Disabled

High Latency Disk Warning : Disabled

Back Finish Cancel

Figure 9-10 Create a Thin Provisioning Pool Step 5

13. After confirmation of info on the summary page, click the **Finish** button to create a pool.

	Pool Name	Status	Health	Total	Free	Available	Thin Provisioning	Encryption	Volumes	Current Controller
▼	Pool-2	Online	Good	3.27 TB	3.27 TB	3.27 TB	Enabled	Disabled	0	Controller 1

Create Pool

Figure 9-11 A Thin Provisioning Pool is Created

14. A pool has been created. If necessary, click the **Create Pool** button again to create others.

9.3.2. List Thin Provisioning Pools

Click a pool; it will display the related disk groups. Similarly, click a disk group; it will display the related disk drives. The pool properties can be configured by clicking the functions button ▼ to the left side of the specific pool.

	Pool Name	Status	Health	Total	Free	Available	Thin Provisioning	Encryption	Volumes	Current Controller
▼	Pool-2	Online	Good	3.27 TB	3.27 TB	3.27 TB	Enabled	Disabled	0	Controller 1

Disk Groups

	No.	Status	Health	Total	Free	RAID	Disks Used	RAID EE Spares
▼	1	Online	Good	3.27 TB	3.27 TB	RAID 5	4	N/A

Disks

Enclosure ID	Slot	Status	Health	Capacity	Disk Type	Manufacturer	Model
0	9	Online	Good	1.09 TB	SAS HDD 12.0Gb/s	SEAGATE	ST1200MM0088
0	10	Online	Good	1.09 TB	SAS HDD 12.0Gb/s	SEAGATE	ST1200MM0088
0	11	Online	Good	1.09 TB	SAS HDD 12.0Gb/s	SEAGATE	ST1200MM0088
0	12	Online	Good	1.09 TB	SAS HDD 12.0Gb/s	SEAGATE	ST1200MM0088

Create Pool

Figure 9-12 List Thin Provisioning Pools

This table shows the column descriptions.

Table 9-3 Pool Column Descriptions

Column Name	Description
Pool Name	The pool name.
Status	The status of the pool: <ul style="list-style-type: none"> Online: The pool is online. Offline: The pool is offline. Rebuilding: The pool is being rebuilt. Migrating: The pool is being migrated. Relocating: The pool is being relocated. EE Rebuilding: The pool is being RAID EE rebuilt.
Health	The health of the pool:

	<ul style="list-style-type: none"> • Good: The pool is good. • Failed: The pool has failed. • Degraded: The pool is not healthy and not completed. The reason could be lack of disk(s) or have failed disk.
Total	Total capacity of the pool.
Free	Free capacity of the pool.
Available	Available capacity of the pool.
Thin Provisioning	The status of Thin provisioning: <ul style="list-style-type: none"> • Disabled. • Enabled.
Encryption	The Data Secure Mode: <ul style="list-style-type: none"> • Disabled: The pool is not encrypted. • Enabled: The pool is encrypted.
Volumes	The quantity of volumes in the pool.
Current Controller (This option is only visible when dual controllers are installed.)	The current running controller of the pool.

Table 9-4 Disk Group Column Descriptions

Column Name	Description
No.	The number of the disk group.
Status	The status of the disk group: <ul style="list-style-type: none"> • Online: The disk group is online. • Offline: The disk group is offline. • Rebuilding: The disk group is being rebuilt. • Migrating: The disk group is being migrated. • Relocating: The disk group is being relocated. • EE Rebuilding: The disk group is being RAID EE rebuilt.
Health	The health of the disk group: <ul style="list-style-type: none"> • Good: The disk group is good. • Failed: The disk group has failed. • Degraded: The pool is unhealthy and incomplete. The cause may be a disk loss or failure.
Total	Total capacity of the disk group.

Free	Free capacity of the disk group.
RAID	The RAID level of the disk group.
Disks Used	The quantity of disk drives in the disk group.
RAID EE Spare	The quantity of RAID EE spare disk drives in the disk group. Traditional RAID level is display as N/A.

Table 9-5 Disk Column Descriptions

Column Name	Description
Enclosure ID	The enclosure ID.
Slot	The position of the disk drive.
Status	<p>The status of the disk drive:</p> <ul style="list-style-type: none"> • Online: The disk drive is online. • Missing: The disk drive is missing in the pool. • Rebuilding: The disk drive is being rebuilt. • Transitioning: The disk drive is being migrated or is replaced by another disk when rebuilding occurs. • Scrubbing: The disk drive is being scrubbed. • Check Done: The disk drive has been checked the disk health. • Copying Back: The disk drive is being copied back.
Health	<p>The health of the disk drive:</p> <ul style="list-style-type: none"> • Good: The disk drive is good. • Failed: The disk drive has failed. • Error Alert:

Change Thin Provisioning Policy of the Pool

Click ▼ -> **Change Thin Provisioning Policy** in pools to change the policies of the thin provisioning pool. There are 2 levels of threshold percentage and the default values defined. The threshold percentage can be changed when the usage of the pool capacity reaches the threshold. For more information, please refer to the chapter 9.2.3, [Thin Provisioning Policies](#) section.

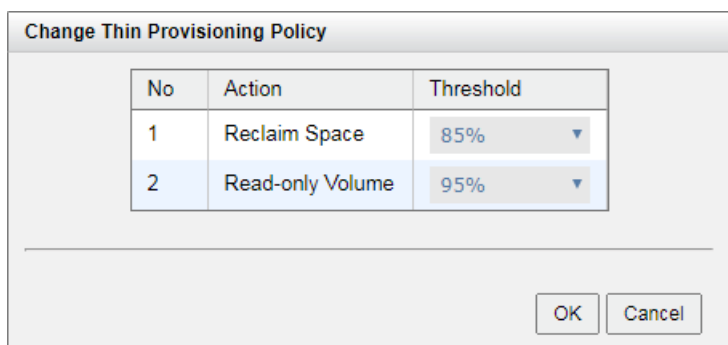

Figure 9-13 Change Thin Provisioning Policy

Table 9-6 Thin Provisioning Policy Column Descriptions

Column Name	Description
No.	Number of item.
Action	Action to take on the system when the usage of the pool reaches the threshold. The options are: <ul style="list-style-type: none"> • Reclaim Space • Read-only Volume
Threshold	The threshold of the pool.

Add a Disk Group into the Pool

Click ▼ -> **Add Disk Group** in one of pools to add another disk group into the pool. For more information, please refer to the chapter 9.3.4, [Add a Disk Group in a Thin Provisioning Pool](#) section.

If the auto tiering license is enabled, you can click ▼ -> **Add Disk Group** in one of pools to transfer from the thin provisioning pool to auto tiering pool. For more information, please refer to the chapter 11.7, [Transfer to Auto Tiering Pool](#) section.

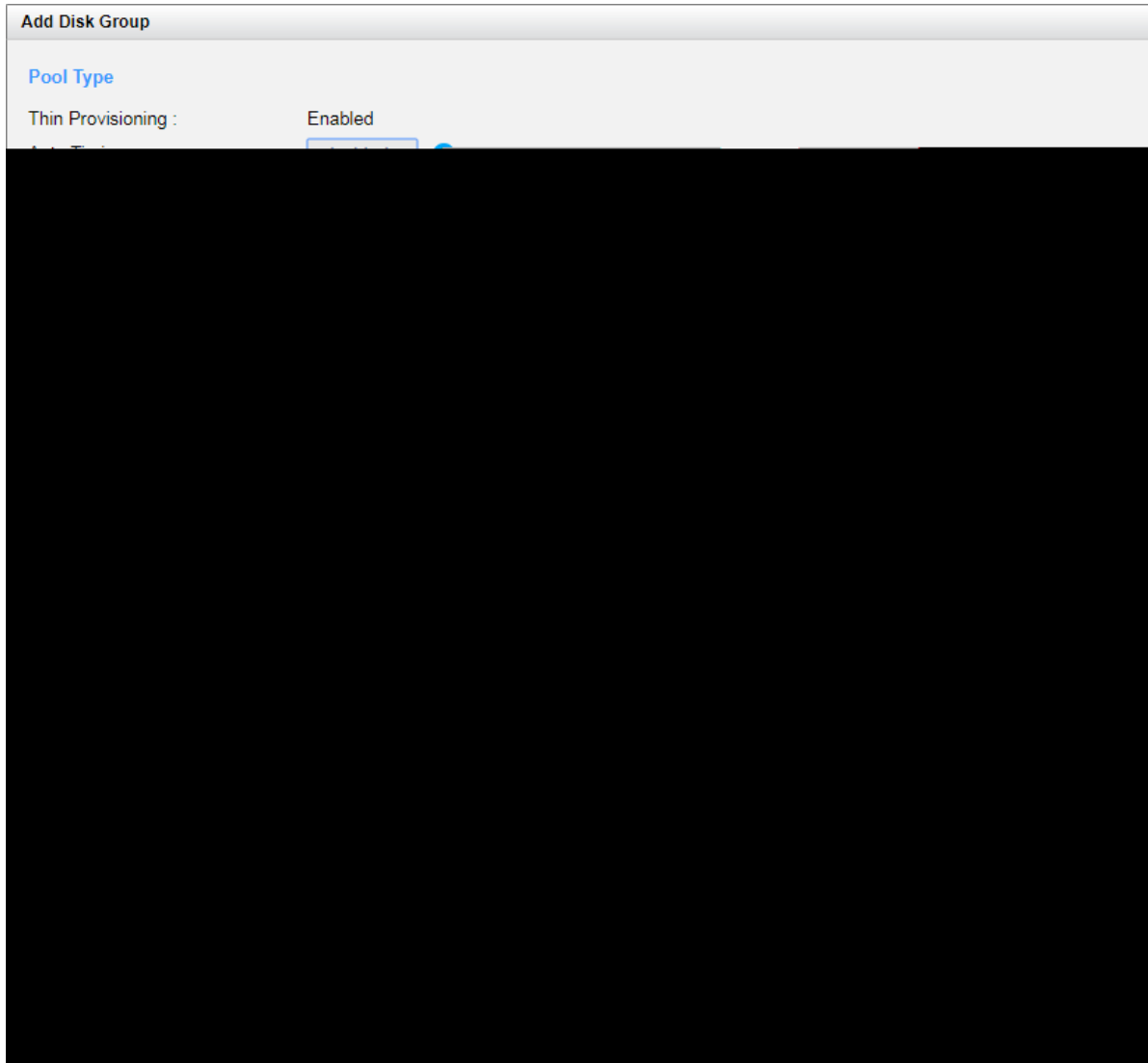

Figure 9-14 Transfer Thin Provisioning Pool to Auto Tiering



CAUTION:

The action of transferring from the thin provisioning pool to auto tiering is irreversible. Carefully consider the consequences before making this change.

Move Disk Group Member Disks

Click ▼ -> **Move Disk Group** in disk group to move the member disks of disk group to other disk drives. Select disks and then click the **OK** button.

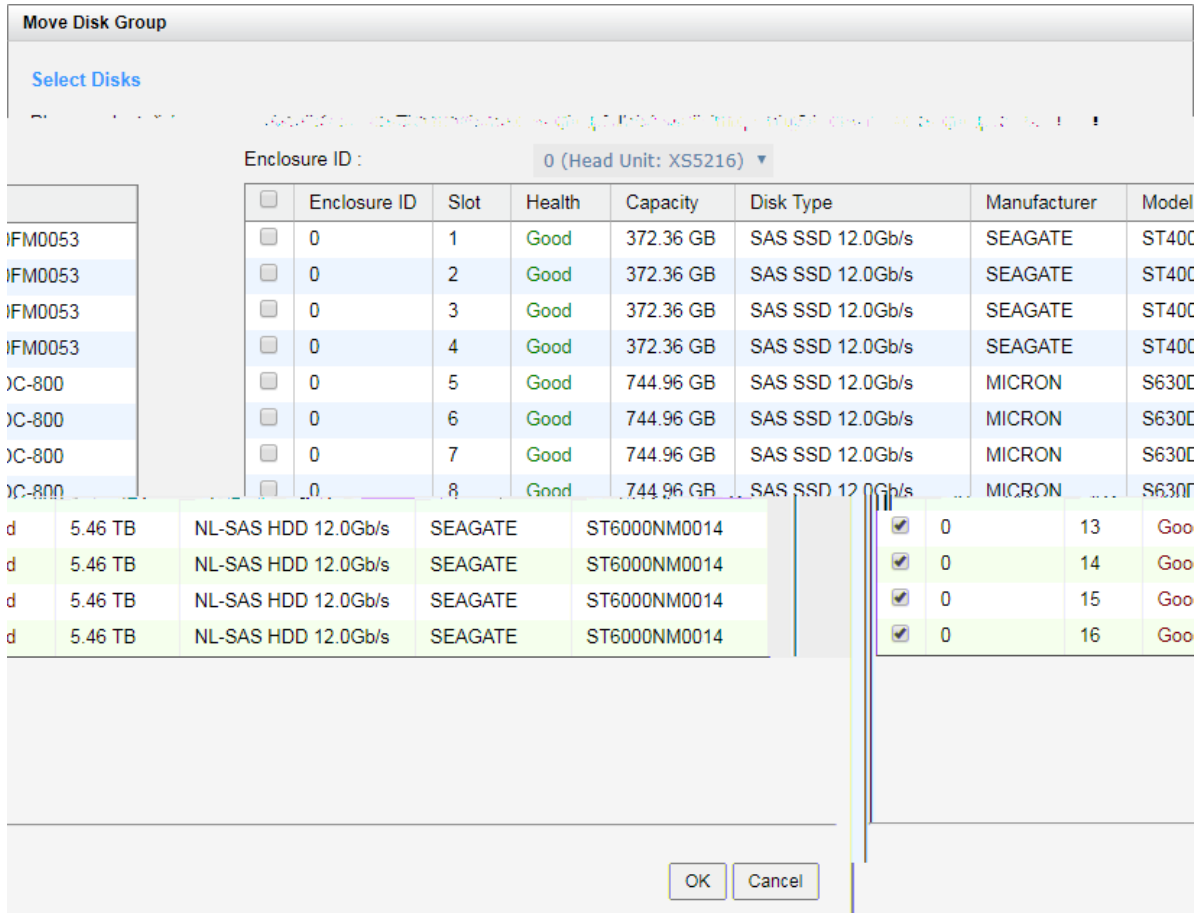

Figure 9-15 Move Disk Group



INFORMATION:

The capacity after moving must be larger than the current capacity.

9.3.4. Add a Disk Group in a Thin Provisioning Pool

The **Add Disk Group** function adds a disk group to a pool to increase the capacity.

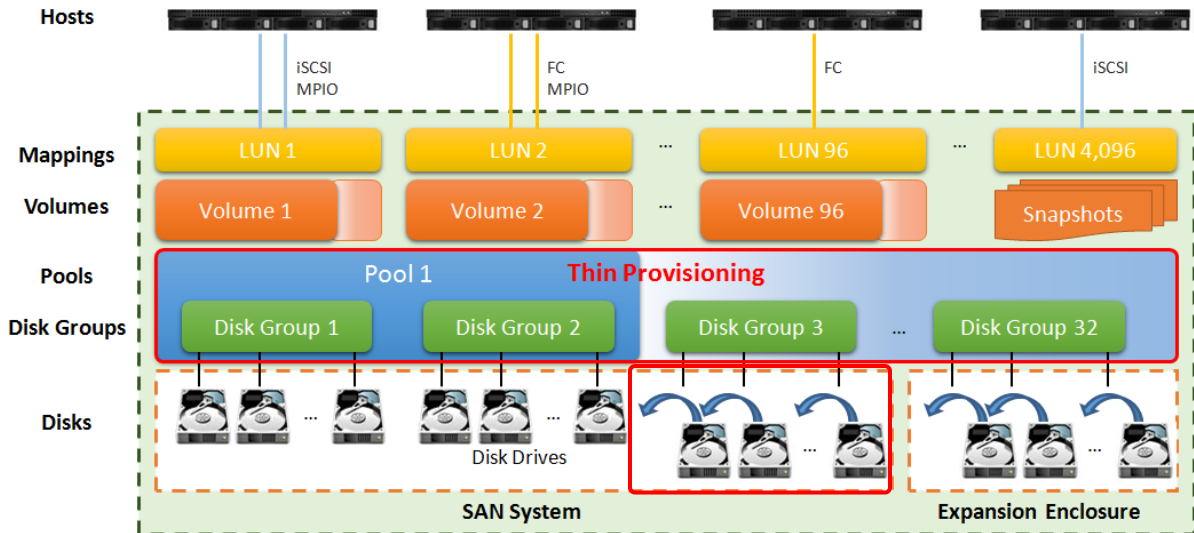

Figure 9-16 Add a Disk Group in a Thin Provisioning Pool

Here is an example of adding a disk group into a thin provisioning pool with 2 disks configured in RAID 1.

1. Select a pool, click ▼ -> **Add Disk Group** to add a disk group in a thin provisioning pool.

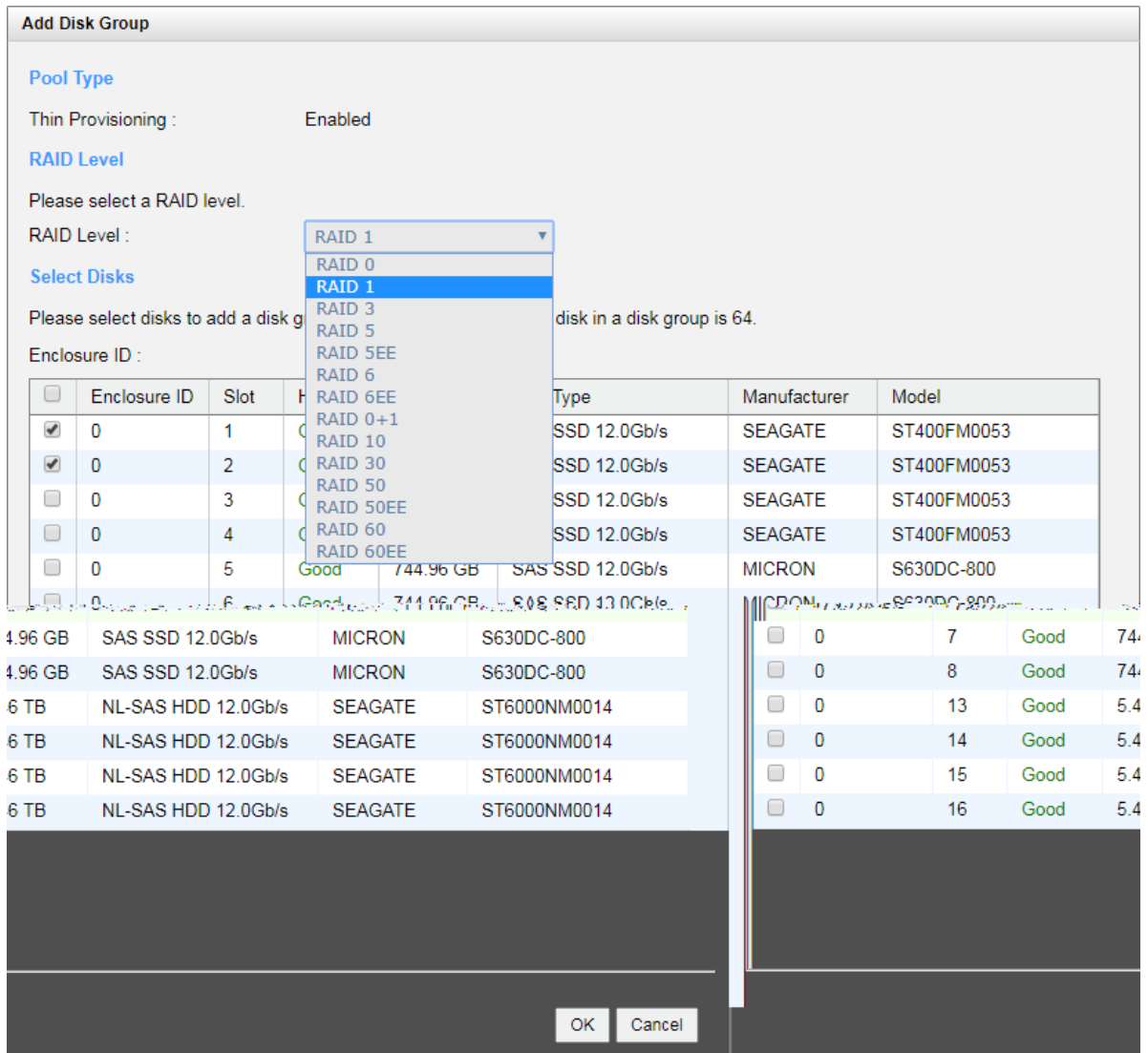

Figure 9-17 Add a Disk Group to a Thin Provisioning Pool

2. Select a **RAID Level** from the drop-down list and also select a **Quantity of Subgroups** if the combination RAID level is selected.
3. Select disks to add into a disk group. The maximum quantity of disk in a disk group is 64. Select an **Enclosure ID** from the drop-down list to select disks from expansion enclosures.
4. Click the **OK** button to add a disk group into the pool.

	Pool Name	Status	Health	Total	Free	Available	Thin Provisioning	Encryption	Volumes	Current Controller
▼	Pool-2	Online	Good	3.64 TB	3.64 TB	3.64 TB	Enabled	Disabled	0	Controller 1

Disk Groups

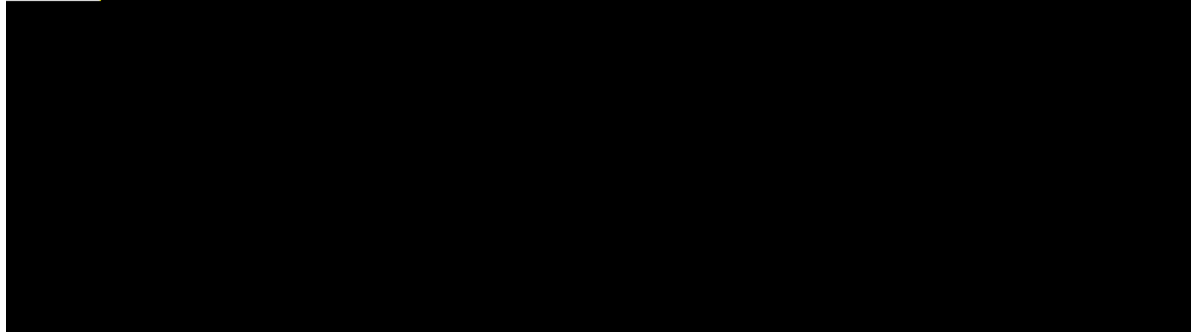

Figure 9-18 A Disk Group is Added

5. A disk group has been added into the pool.



TIP:

If auto tiering license is enabled, the thin provisioning pool without disk group of mixed disk type can be transferred to the auto tiering pool by **Add Disk Group** option. Please refer to the chapter 11.6.2, [Transfer from Thin Provisioning Pool to Auto Tiering](#) section.

9.4. Configure Volumes

This section will describe the operations of configuring volume in a thin provisioning pool.

9.4.1. Create a Volume in a Thin Provisioning Pool

Here is an example of creating a volume of thin provisioning pool.

1. Select the **Volumes** function submenu, click the **Create Volume** button.

Figure 9-19 Create a Volume in Thin Provisioning Pool Step 1

2. Enter a **Volume Name** for the pool. The maximum length of the volume name is 32 characters. Valid characters are [A~Z | a~z | 0~9 | -_<>].
3. Select a **Pool Name** from the drop-down list. It will also display the available capacity of the pool.
4. Enter required **Capacity**. The unit can be selected from the drop-down list.
5. Select **Volume Type**. The options are **RAID Volume** (for general RAID usage) and **Backup Volume** (for the target volume of local clone or remote replication).
6. Click the **Next** button to continue.

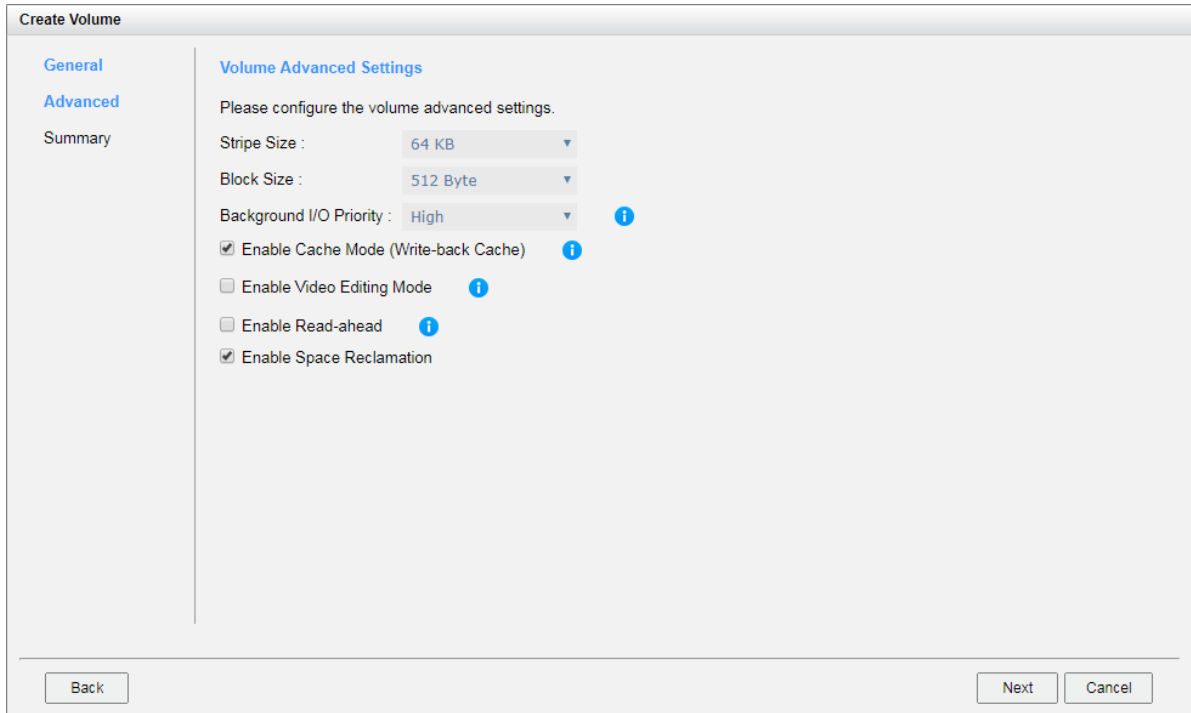

Figure 9-20 Create a Volume in Thin Provisioning Pool Step 2

7. Volume advanced settings can also be configured optionally in this step:

Stripe Size: The options are 64KB to 1,024KB.

Block Size: The options are 512Bytes to 4,096Bytes.

Background I/O Priority: The options are High, Medium, and Low. It will influence volume initialization, rebuild, and migration.

Enable Cache Mode (Write-back Cache): Check to enable cache mode function of volume. Write back optimizes the system speed but comes with the risk where the data may be inconsistent between cache and disks in one short time interval.

Enable Video Editing Mode: Check to enable video editing mode function. It is optimized for video editing usage. Please enable it when your application is in video editing environment. This option provides a more stable performance figure without high and low peaks but slower in average.

Enable Read-ahead: Check to enable the read ahead function of volume. The system will discern what data will be needed next based on what was just retrieved from disk and then preload this data into the disk's buffer. This feature will improve performance when the data being retrieved is sequential.

Enable Space Reclamation: Check to enable the space reclamation function of the volume when the pool is thin provisioning. For more information about space reclamation, please refer to the chapter 9.2.2, [Space Reclamation](#) section.



INFORMATION:

Stripe sizes from 64KB to 1,024KB support more than 8GB of memory for resource allocation. 4GB memory is only support 64KB stripe size.

8. Click the **Next** button to continue.

Figure 9-21 Create a Volume in Thin Provisioning Pool Step 3

- 9. After confirmation at summary page, click the **Finish** button to create a volume.
- 10. The volume has been created. It will be initialized in protection RAID level (e.g., RAID 1, 3, 5, 6, 0+1, 10, 30, 50, and 60).

<< first < prev **1** next > last >>

	Volume Name	Status	Health	Capacity	Volume Type	SSD Cache	Snapshot Space	Snapshots	Clone	Write	Pool Name
▼	Vol-2	Online	Optimal	100.00 GB	RAID Volume	Disabled	0 MB / 0 MB	0	N/A	WB	Pool-2

<< first < prev **1** next > last >>

Create Volume Local Clone Options

Figure 9-22 A Volume in Thin Provisioning Pool is Created

11. A volume has been created. If necessary, click the **Create Volume** button again to create others.



INFORMATION:

SANOS supports instant RAID volume availability. The volume can be used immediately when it is initializing or rebuilding.



TIP:

If the pool contains some disk drives of 4Kn type, it is not available to set 512, 1024, or 2048 block size. When the case happens, it will pop up a warning message and suggest changing the block size to 4096.

9.4.2. List Volumes and Operations on Volumes

Most operations are described in the chapter 8.5, [Configuring Volumes](#) section. For more information about list volume, please refer to the chapter 8.5.2, [List Volumes](#) section. For more information about operations on volumes, please refer to the chapter 8.5.3, [Operations on Volumes](#) section. We describe the operations about thin provisioning in the following.

Change Volume Properties

Click ▼ -> **Change Volume Properties** to change the volume properties of the volume.

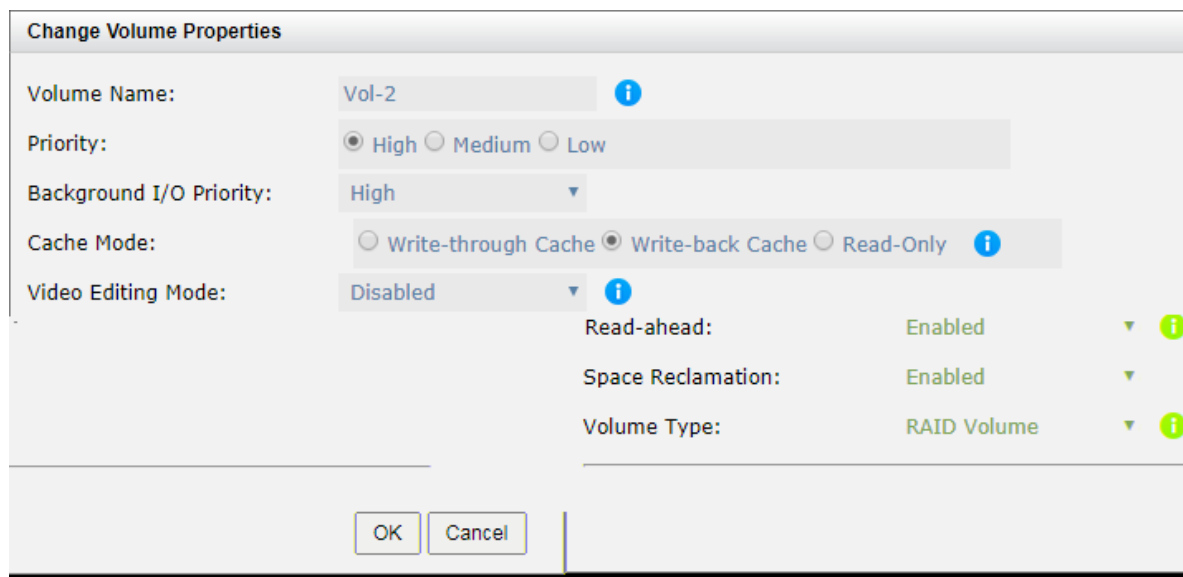

Figure 9-23 Change Volume Properties

Reclaim Space with Thin Provisioning Pool

Click ▼ -> **Space Reclamation** to reclaim space from the volume when the volume is in a thin provisioning pool. For more information about space reclamation, please refer to the chapter 9.2.2, [Space Reclamation](#) section.

9.5. Configure LUN Mappings and Connect by Host Initiator

Next step, you can configure LUN mapping and connect by host initiator. For more information about LUN mapping, please refer to the chapter 8.6, [Configure LUN Mappings](#) section. For more information about host initiator, please refer to the chapter 8.7, [Connect by Host Initiator](#) section.

10. SSD Cache

This chapter describes an overview and operations of SSD cache. Now we provide two cache types, SSD read cache and read-write cache.

**INFORMATION:**

SSD cache 2.0 with read and write cache is available in SANOS firmware 1.1.0.

10.1. Overview

Traditionally, data has been stored on traditional rotating memory, or HDDs (Hard Disk Drives) and SSDs (Solid-State Drives) are mainly used for mission-critical applications that demand high-speed storage systems, however tend to be costly. In recent years, the capacity of HDDs has increased, but their random I/O (Input / Output) has not kept pace. For some applications such as web commerce, clouds, and virtualization that require both high capacity and performance, HDDs, though capacious, simply are not fast enough and SSDs have increased capacity and have declined in cost, making them more attractive for caching in SAN storage networks.

Smart Response Technology (also known as SSD cache technology) leverages the strengths of both HDDs and SSDs, to cost-effectively meet the capacity and performance requirements of enterprise applications. Data is primarily stored on HDDs while SSDs serve as an extended HDD memory cache for many I/O operations. One of the major benefits of using SSD cache is the improved application performance, especially for workloads with frequent I/O activity. The read data of an application that is frequently accessed is copied to the SSD cache; the write data is stored to the SSD cache temporary and then flush to HDDs in bulk. So the application receives an immediate performance boost. QSAN SSD cache enables applications to deliver consistent performance by absorbing bursts of read/write loads at SSD speeds.

Another important benefit is improved TCO (Total Cost of Ownership) of the system. SSD cache copies the hot or frequency of data to SSDs in chunks. By offloading many if not most of the remaining IOPS after SSD cache, the user can fill the remainder of their storage needs with low cost, high capacity HDDs. This ratio of a small amount of SSD paired with a lot of HDD offers the best performance at the lowest cost with optimal power efficiency.

Generally, SSD read cache is particularly effective when:

- Reads are far more common than writes in the production environment, common in live database or web service applications.
- The inferior speeds of HDD reads cause performance bottlenecks.
- The amount of repeatedly accessed data is smaller than the capacity of the SSD cache.

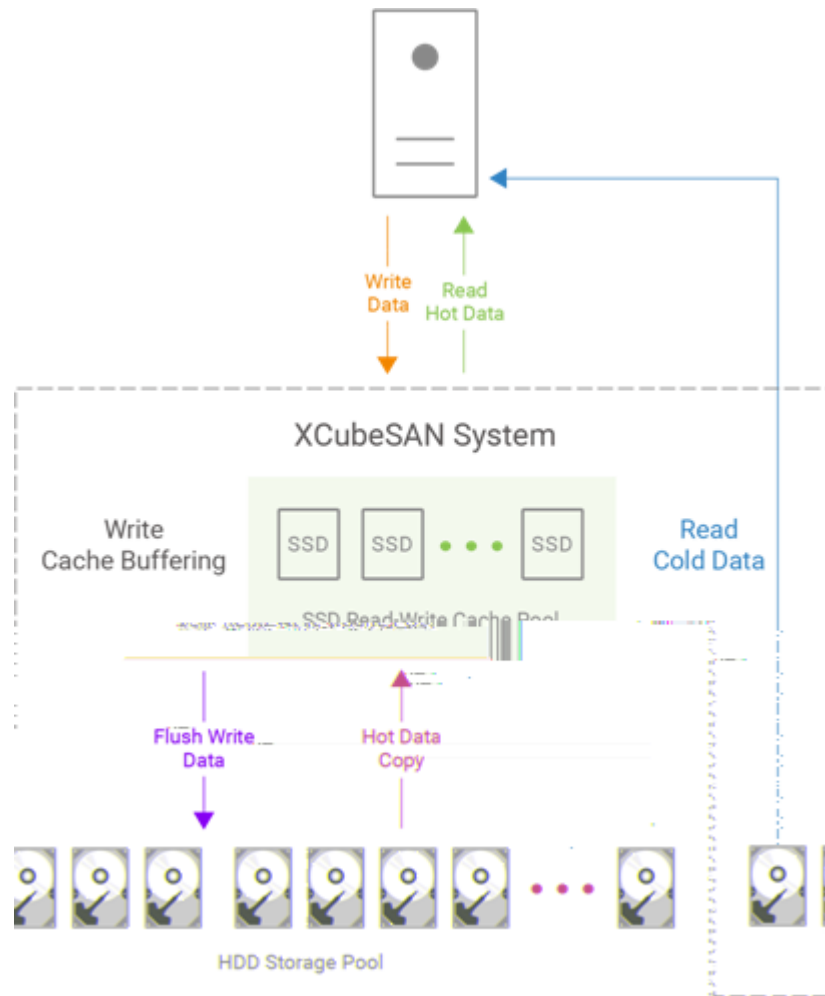

Figure 10-1 SSD Read and Write Cache

SSD read-write cache is particularly effective when:

- Reads and writes mix in the production environment, common in file service applications.
- The inferior speeds of HDD reads and writes cause performance bottlenecks.
- Same as SSD read cache case; the size of repeatedly accessed data is smaller than the capacity of the SSD cache.

- Willing to take a little risk to increase write performance because it's write cache buffering at SSD cache pool. Of course, these write data in SSD cache can be used at the next read.

10.2. Theory of Operation

SSD cache allows an SSD to function as read cache or write buffer for a HDD volume. In SSD read cache, it is a secondary cache that improves performance by keeping frequently accessed data on SSDs where they are read far more quickly than from the HDD volume. When reads or writes are performed, the data from the HDDs are copied into the SSD cache. Although the data is duplicated to SSD cache pool, it does not matter if the read cache pool is corrupted.

In SSD write cache, SSDs are a write buffering storage that improves performance by storing the write data in SSDs temporary where they are write far more quickly than to the HDD volume. And then the write data will be flushed to the HDD volume at the appropriate time. It may take risk of losing data during the period that the write data is stored in SSD cache if the SSD cache pool is corrupted. The write data has not yet written back to the HDD volume. So the read-write cache pool needs data protection to protect the write data.



CAUTION:

Using SSD read-write cache may take risk of losing data if the SSD cache pool is corrupted. User has to monitor the health of the SSD cache pool carefully.

10.2.1. System Memory and SSD Cache Capacity

SSD cache function needs system memory to store metadata. The usable capacity of SSD cache is in proportion to the size of the controller system memory. The following table is the relationship between the system memory per controller and the maximum SSD cache capacity.

Table 10-1 The Relationship between System Memory and SSD Cache Capacity

System Memory per Controller	Maximum SSD Cache Capacity per System
4GB	X (Not Support)
8GB ~ 15GB	2TB
16GB ~ 31GB	4TB
32GB ~ 63GB	8TB
64GB ~ 127GB	16TB
128GB	32TB



CAUTION:

SSD cache function is not supported when the system memory is under 8GB per controller.

10.2.2. SSD Cache Pool Architecture

A SSD cache pool is grouped to provide capacity for SSD cache usage of a dedicated storage pool. The maximum SSD cache pool quantity per system (either dual controller or single controller) is 4. The following is the storage architecture of SSD cache pool.

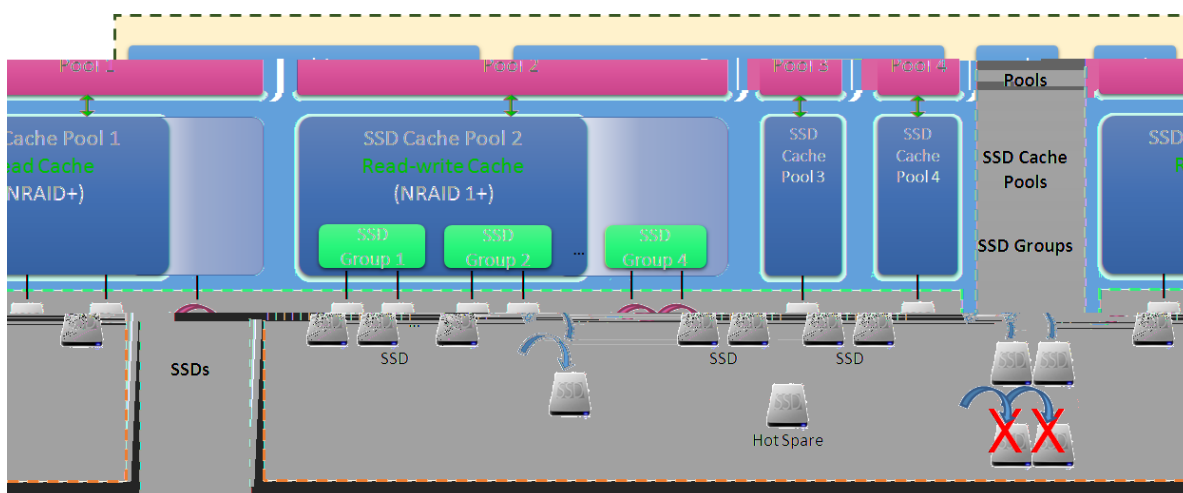

Figure 10-2 Storage Architecture of SSD Cache Pool

Take an example of SSD read cache; one or more SSDs with NRAID+ (which is described in the next section) are grouped into the “SSD Cache Pool 1” and assigned to the “Pool 1” for use. The maximum SSD quantity in an SSD cache pool is 8. When the SSD read cache is

performing, the capacity of the SSD cache can be increased by adding an SSD or decreased by removing an SSD.

Another example of SSD read-write cache; two SSDs with NRAID 1+ (which is also described in the next section) are grouped into an SSD group. One or more SSD groups combine to the “SSD Cache Pool 2” and assigned to the “Pool 2” for use. When the SSD read-write cache is performing, the capacity of the SSD cache can be increased only by adding an SSD group with two SSDs at a time. The SSD read-write cache pool can set SSDs as dedicated hot spares. The maximum dedicated spare SSD quantity in an SSD cache pool is 4. The following table is the summary of the SSD cache parameters.

Table 10-2 SSD Cache Parameters

Item	Value
Maximum SSD cache pool quantity per system (either dual controller or single controller)	4
Maximum SSD quantity in an SSD cache pool	8
Maximum addressable capacity of an SSD cache pool	32TB
Maximum quantity of volume shared in an SSD cache pool	32
Maximum dedicated spare SSD quantity in an SSD cache pool	4



CAUTION:

Note that the capacity allocated to the SSD cache pool is not counted in the regular data storage.

The volumes in pool can be selected to enable SSD cache function. The following is the relationship between SSD cache pool and storage pool.

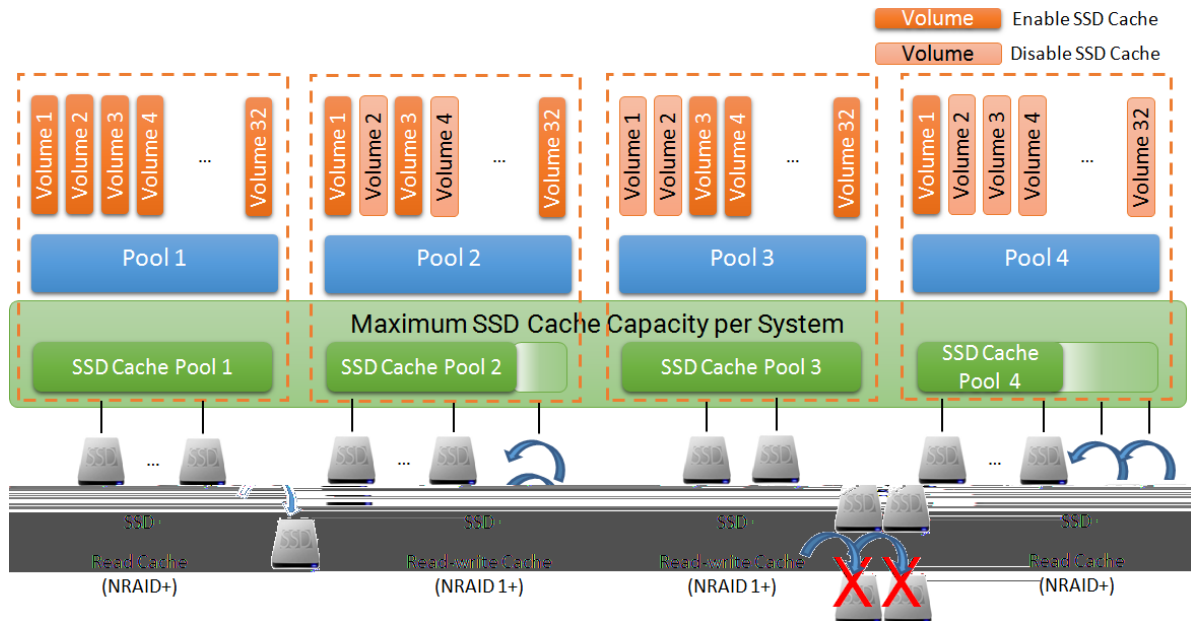

Figure 10-3 The Relationship between SSD Cache Pool and Storage Pool

The volumes enabled SSD cache with hot data will consume the capacity of the SSD cache pool. Users have to consider which volumes are enabled according to the SSD cache resources. When the SSD cache is performing, you can enable or disable the volume. The maximum quantity of volume shared in an SSD cache pool is 32.

10.2.3. RAID Level of SSD Cache Pool

SSD read cache with NRAID+

Generally, SSD read cache uses NRAID (Non-RAID) or RAID 0 without data protection to create the SSD cache storage space. Our SSD read cache technology uses NRAID+ which is parallel NRAID without striping.

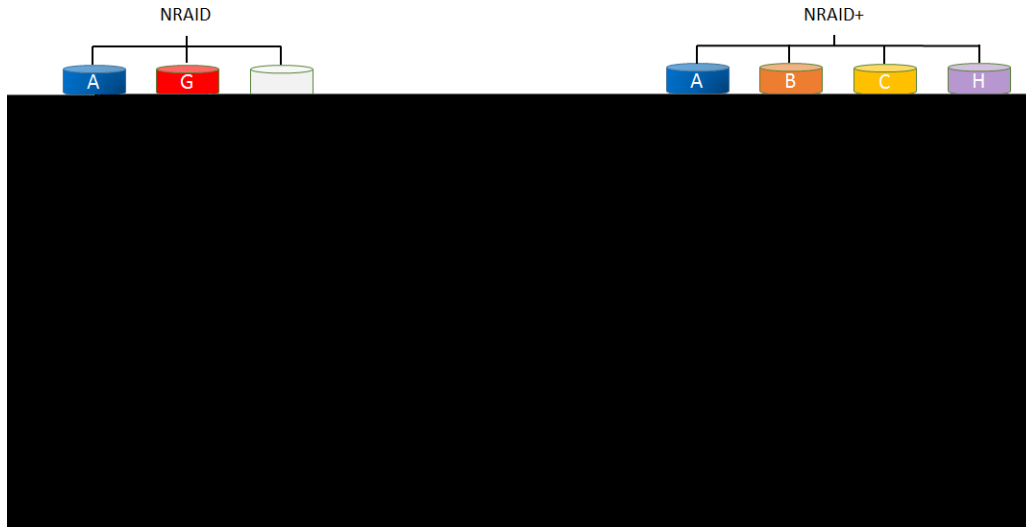

Figure 10-4 SSD Read Cache with NRAID+

NRAID is a method of combining the free space on multiple disk drives to create a spanned capacity. A NRAID is generally a spanned volume only, as it can contain disk drives of various types and various sizes. RAID 0 consists of striping, without mirroring or parity. Adding a disk drive into RAID 0 needs to re-stripe the data. For SSD cache, it will have terrible performance when performing SSD cache and migrating RAID 0 at the same time. Let alone remove a disk drive.

Compare to the NRAID or RAID 0, NRAID+ distributes cache data over all SSDs. This NRAID+ technology combines with the advantages of NRAID and has better random I/O than NRAID. It also has the advantage of easy to add/remove SSDs from the SSD cache pool to increase/decrease the capacity.

Although the SSD read cache is a technique of duplicating data. If the SSD cache pool corrupts, the original data will be safe but stop SSD read cache.

SSD read-write cache with NRAID 1+

SSD read-write cache needs data protection, so it usually uses RAID 1 or RAID 10 level to create the SSD cache storage space. Our SSD read-write cache technology uses NRAID 1+ which is parallel NRAID with mirror.

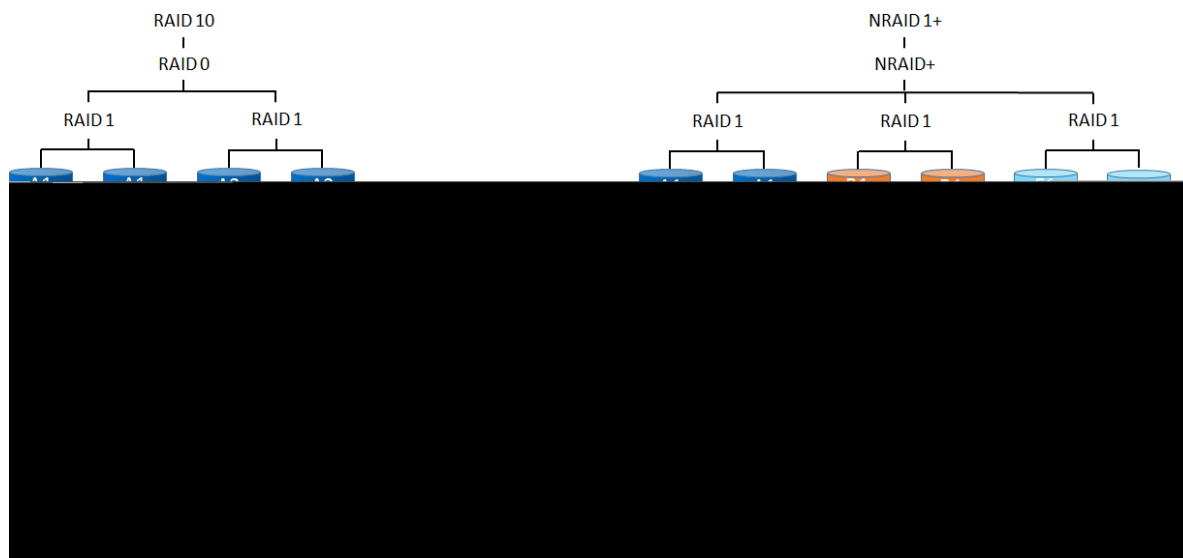

Figure 10-5 SSD Read-write Cache with NRAID 1+

RAID 10 creates a striped set from a series of mirrored drives. The same, adding pair disk drives into RAID 10 needs to re-stripe the data. So it is hard to add SSDs into SSD cache pool.

Compare to the RAID 10, NRAID 1+ distributes cache data over all mirrored SSDs. This NRAID 1+ technology has the data protection and better random I/O than RAID 10. It also has the advantage of easy to add SSDs into the SSD cache pool to increase the capacity. In this case, we disallow the SSDs to be removed from the SSD cache pool because it has the risk of losing write cache data.

If one SSD failure occurs in the SSD cache pool, the status of the SSD cache pool will be changed to degrade. It will stop write cache and start flushing write cache data into HDDs. At this time, read cache data is still working but no more new read cache data will be added into SSD cache pool. The SSD read-write cache pool can set SSDs as dedicated hot spares to prevent SSD cache pool failure. After inserting an SSD as a hot spare, the SSD read-write cache pool will be rebuilt until it is completed. And then it reverts to SSD read-write cache service.

10.2.4. Read/Write Cache Cases

The following describes the cases of read/write cache. In SSD read cache, the processes of read/write data will be disassembled to the following cases.

- Read Data with Cache Miss

- Read Data with Cache Hit
- Write Data in SSD Read Cache

Besides, in SSD read-write cache, the processes of read data are the same as above. But the write data is different. The processes of write data will be described on following case.

- Write Data in SSD Read-write Cache

Each case will be described below.

Read Data with Cache Miss

The following figure shows how the controller handles a host read request when some or all of the data are not in the SSD cache.

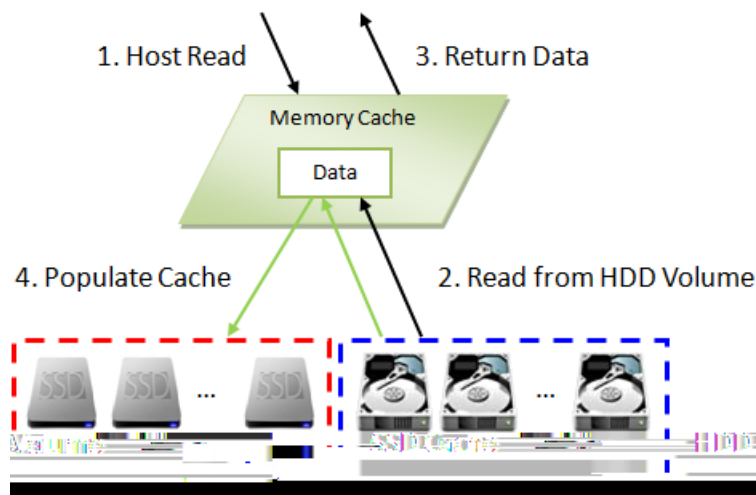

Figure 10-6 Read Data with Cache Miss

These steps are:

1. A host requests to read data. The system will check if the requested data is in memory cache or SSD cache. If not, it is called cache miss.
2. Data is read from the HDD volume because of cache miss.
3. The requested data is returned to the host. And the system will check whether the requested data is hot data.
4. If it is, the SSD cache is populated.



INFORMATION:

The actions that read data from the HDD and then write to the SSD are called populating the cache. For more information, please refer to the chapter 10.2.5, [Populating the Cache](#) in the next section.

Read Data with Cache Hit

The following figure shows how the controller handles a host read request when the data is in the SSD cache.

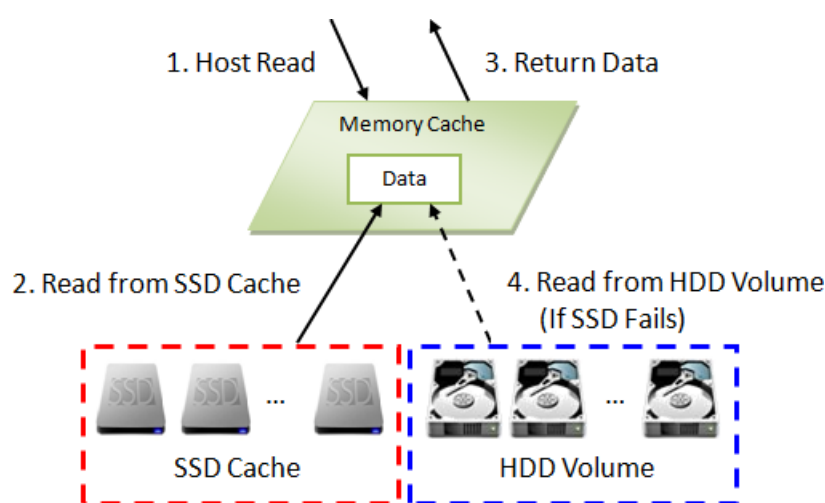

Figure 10-7 Read Data with Cache Hit

These steps are:

1. A host requests a read data. The system finds that the data is in SSD cache, so it is called cache hit.
2. Data is read from the SSD cache.
3. The requested data is returned to the host.
4. If there is an SSD cache error, data is read from the HDD volume.

Write Data in SSD Read Cache

The following figure shows how the controller handles a host write request in SSD read cache. The write data can also be frequently accessed data and populated into SSD cache for next read.

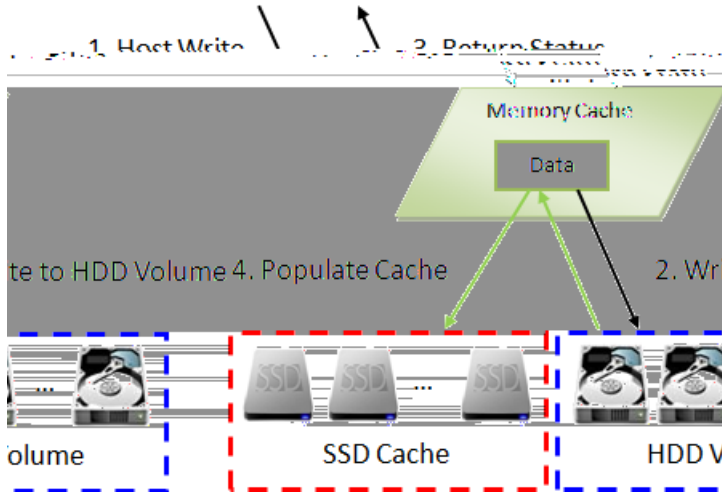

Figure 10-8 Write Data in SSD Read Cache

These steps are:

1. A host requests to write data.
2. Data is written to the HDD volume.
3. The status is returned to the host.
4. The SSD cache is populated if the write threshold is reached.

Write Data in SSD Read-write Cache

The following figure shows how the controller handles a host write request in SSD read-write cache. The write data stays in the SSD cache for a while, and will be flushed to the HDD volume at the appropriate time.

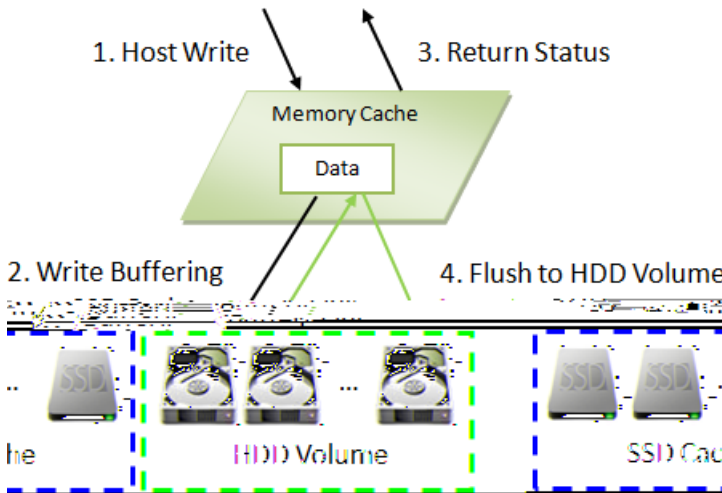

Figure 10-9 Write Data in SSD Read-write Cache

These steps are:

1. A host requests to write data.
2. Data is written to the SSD cache.
3. The status is returned to the host.
4. Data will be flushed to the HDD volume at the appropriate time.

Flush Write Data to HDD Volume

In SSD read-write cache, the write data will be flushed to the HDD volume in the following situations.

- Flush data to the HDD volumes before the SSD cache pool is deleted.
- Flush data to the HDD volumes before the related volume is disabled.
- Flush data when the system is idle.



CAUTION:

It will take times to flush data from SSD cache to HDD volumes. Please do not remove SSDs before complete flushing; otherwise it may take risk of losing data.

In addition, to avoid taking a long time to complete flushing, please make sure the front I/O traffic is not heavy when deleting SSD cache pool.

It won't flush data to the HDD volumes when system goes shutdown or reboots.

10.2.5. Populating the Cache

The actions that read data from the HDD and then write to the SSD are called populating the cache. Typically, this is a background operation that immediately follows a host read or write operation. As the goal of the cache is to store frequently accessed data, not every I/O operation should trigger a cache population, but only ones that pass a certain threshold, implemented as a counter. There are both a populate-on-read threshold, and a populate-on-write threshold.

Populate-on-read Threshold

When the same data block to be read over the threshold, it is called hot data and populated to the SSD cache. The threshold must be greater than or equal to 1 in SSD read cache or SSD read-write cache. The value is forbidden to set 0 because of no action in read cache. The maximum of the threshold is 4. If larger than 4, the frequently accessed data is hard into SSD cache, so there is no obvious effect.

Populate-on-write Threshold

When the same data block to be written over the threshold, it is called hot data and populated to the SSD cache. The threshold must be greater than or equal to 0. If it is set to 0, no action is performed for a write cache. The value must be greater than or equal to 1 in SSD read-write cache. The value is forbidden to set 0 because of no action in write cache. The same as above, the maximum of the threshold is 4. If larger than 4, there is no obvious effect.

Operation Process

Each cache block on a HDD volume has a read and write counter associated. When a host requests to read data located in that cache block, the read count is increased. If the data is not found in the cache and the read count is greater than or equal to the populate-on-read threshold, then a cache-populate operation is performed concurrently with the host read operation. If a cache hit occurs, the data is immediately returned from the SSD cache and a populate operation is not performed. If the read count is smaller than the threshold, a populate operation is not performed.

Write cases are the same scenario as read.

10.2.6. SSD Cache Tuning

The SSD cache can be tuned to maximize its efficiency base on application usage. Cache block size, populate-on-read threshold and populate-on-write-threshold are the main parameters.

Cache Block Size

A large cache block suits applications where frequently accessed data is close to each other, known as a high locality of reference. A large cache block will also fill up the SSD cache quickly - this is known as the warm-up time. After the cache is warmed up, the performance would be quite good for applications with high locality of reference. Such as the file system or web service usage, the frequently accessed data are based on some

concentrated files which are usually in large block size. However large cache blocks will also generate larger I/O overhead, increasing response time, especially for cache misses.

A smaller cache block size suits applications with data that is less localized, meaning the data is accessed more randomly, such as database usage. The SSD cache will fill up slower, but with more cache blocks, there is greater chance of a cache hit, especially for data with less locality of reference. With a smaller cache block size, cache usage is usually less than with a larger cache block size, but overhead is less, so the penalty for cache misses is less severe.

Population Threshold

The population threshold is the quantity of accesses at which point that cache block is copied to the SSD Cache. A higher number ensures that the cache only stores frequently accessed data so there will not be much cache turnover however it also means the cache will take longer to warm up and be fully effective. A lower number means the cache is warmed up quickly, but may cause excessive cache populations. A populate on read threshold of 2 is sufficient for many applications. Populate-on-write is useful when data that is written to is often read soon after. This is often the case in file systems. Other applications, such as database software, does not have this tendency so populate on write may sometimes even be disabled.

Table 10-3 I/O Type Table for SSD Read Cache

I/O Type	Block Size (Sectors)	Populate-on-Read Threshold	Populate-on-Write Threshold
Database	1MB (2,048)	2	0
File System	2MB (4,096)	2	2
Web Service	4MB (8,192)	2	0
Customization	1MB/2MB/4MB	≥ 1 and ≤ 4	≥ 0 and ≤ 4

Table 10-4 I/O Type Table for SSD Read-write Cache

I/O Type	Block Size (Sectors)	Populate-on-Read Threshold	Populate-on-Write Threshold
Database	1MB (2,048)	2	1
File System	2MB (4,096)	2	1
Web Service	4MB (8,192)	2	1
Customization	1MB/2MB/4MB	≥ 1 and ≤ 4	≥ 1 and ≤ 4

As you can see, there are tradeoffs for increasing or decreasing each parameter. Understanding the data locality of the application is essential and it can be useful to do some field testing to see what works best.

10.3. Configure SSD Cache

The **SSD Cache** provides **SSD Cache Pools** and **SSD Cache Statistics** function tabs to configure and monitor SSD cache. This section will describe the operations of configuring SSD cache.

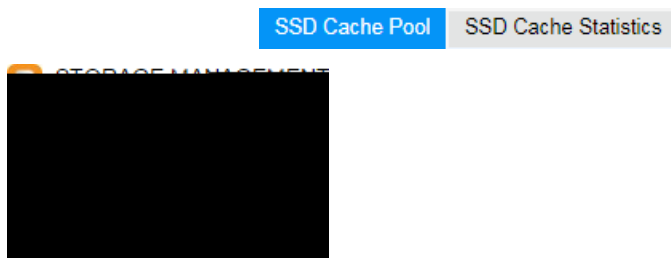

Figure 10-10 SSD Cache Function Submenu

10.3.1. Enable SSD Cache License

The SSD cache function is optional. Before using it, you have to enable SSD cache license. Select the **Update** function tab in the **Maintenance** function submenu, download **Request License** file and send to your local sales to obtain a License Key. After getting the license key, click the **Choose File** button to select it, and then click the **Apply** button to enable. When the license is enabled, please reboot the system. Each license key is unique and dedicated to a specific system. If you have already enabled, this option will be invisible.

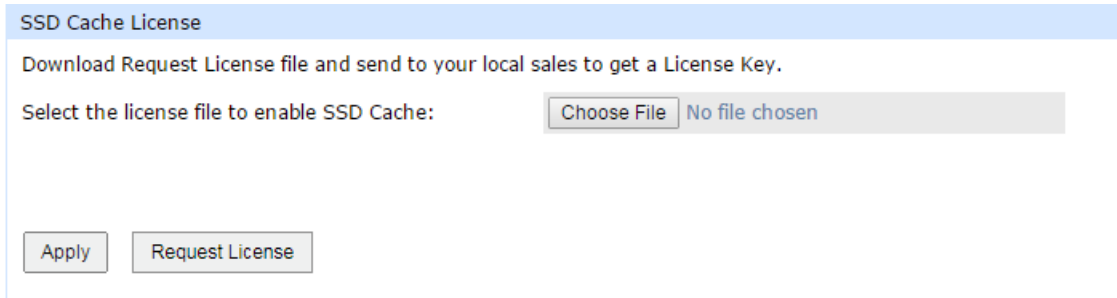

Figure 10-11 Enable SSD Cache License

10.3.2. Create an SSD Cache Pool

Here is an example of creating an SSD cache pool with 2 SSDs configured in SSD read cache.

1. Select the **SSD Cache** function submenu; click the **Create SSD Cache Pool** button. It will scan available SSDs first.

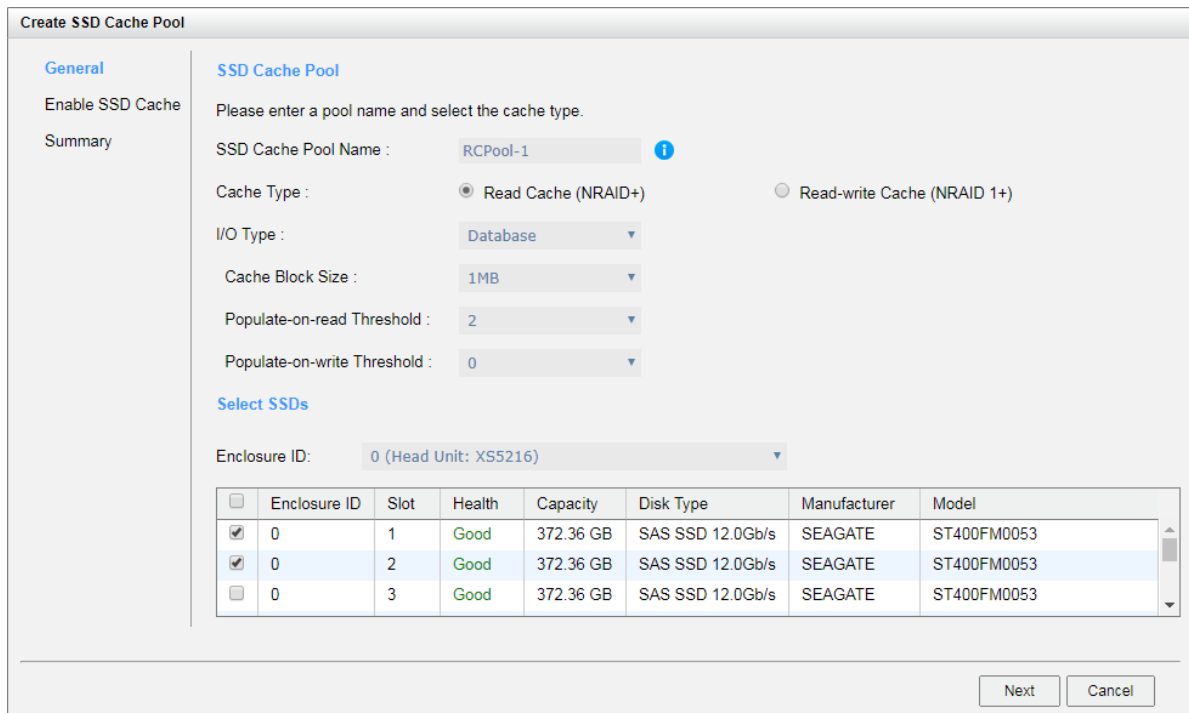

Figure 10-12 Create an SSD Cache Pool Step 1

2. Enter an **SSD Cache Pool Name** for the pool. Maximum length of the pool name is 16 characters. Valid characters are [A~Z | a~z | 0~9 | -_<>].

3. Select the **Cache Type** as Read Cache (NRAID+).
4. Select an **I/O Type** from the drop-down list according to your application.
5. Please select SSDs for SSD cache pool. Maximum quantity of disk is 8. Select an **Enclosure** from the drop-down list to select SSDs from expansion enclosures.
6. Click the **Next** button to continue.

Create SSD Cache Pool

General

Enable SSD Cache

Summary

Select a Pool

Please select a pool to enable SSD cache. The pool can not be change after selection.

Pool Name:

Select Volumes

Within the pool, check volumes to enable SSD cache, uncheck volumes to disable.

<input checked="" type="checkbox"/>	Volume Name	Status	Health	Capacity
<input checked="" type="checkbox"/>	Vol-1	Online	Optimal	100.00 GB
<input checked="" type="checkbox"/>	Vol-2	Online	Optimal	100.00 GB

Back Next Cancel

Figure 10-13 Create an SSD Cache Pool Step 2

7. Select a **Pool Name** from the drop-down list which lists available pools to be assigned to.
8. Within the pool, check **Volumes** to enable SSD cache, uncheck **Volumes** to disable.
9. Click the **Next** button to continue.

Create SSD Cache Pool

General

Enable SSD Cache

Summary

SSD Cache Pool Properties

SSD Cache Pool Name : RCPool-1

Cache Type : Read Cache (NRAID+)

Quantity of SSD : 2

Capacity : 744.72 GB

I/O Type : Database

Enabled Pool and Volumes

Pool Name : Pool-1

Quantity of Enabled Volume : 2

Back Finish Cancel

Figure 10-14 Create an SSD Cache Pool Step 3

10. After confirmation at summary page, click the **Finish** button to create a pool.

	SSD Cache Pool Name	Status	Health	Total	Cache Type	RAID	Pool Name	I/O Type
▼	RCPool-1	Online	Good	744.72 GB	Read Cache	NRAID+	Pool-1	Database

Create SSD Cache Pool

Figure 10-15 An SSD Cache Pool is Created

11. An SSD cache pool has been created.
12. Follow the step 1 to 11 to create another SSD cache pool with Read-write Cache (NRAID 1+) and set the I/O type as File System.

	SSD Cache Pool Name	Status	Health	Total	Cache Type	RAID	Pool Name	I/O Type
▼	RCPool-1	Online	Good	744.72 GB	Read Cache	NRAID+	Pool-1	Database
▼	RWCPool-2	Online	Good	372.36 GB	Read Write Cache	NRAID 1+	Pool-2	File System

Create SSD Cache Pool

Figure 10-16 Another SSD Cache Pool is Created



TIP:

The **Create SSD Cache Pool** button will be grayed out when meet the following conditions.

- There are no available SSDs to create an SSD cache pool.
- There are no available pools which can be assigned to the SSD cache pool including the status of the pool is **Migrating**, **Moving**, **Offline** or the health of the pool is **Failed**.

10.3.3. List SSD Cache Pools

Select one of the SSD cache pools, it will display the related SSDs and enabled volumes. The pool properties can be configured by clicking the functions button ▼ to the left side of the specific pool.

Slot	Status	Health	Capacity	Disk Type	Manufacturer	Model	No.	Enclosure ID
1	Online	Good	372.36 GB	SAS SSD 12.0Gb/s	SEAGATE	ST400FM0053	1	0
2	Online	Good	372.36 GB	SAS SSD 12.0Gb/s	SEAGATE	ST400FM0053	2	0

Volume Name	Status
Vol-2	Online
Vol-1	Online

Figure 10-17 List SSD Cache Pools

This table shows the column descriptions.

Table 10-5 SSD Cache Pool Column Descriptions

Column Name	Description
SSD Cache Pool Name	The SSD cache pool name.
Status	The status of the pool: <ul style="list-style-type: none"> Online: The SSD cache pool is online. Offline: The SSD cache pool is offline. Rebuilding: The SSD cache pool is being rebuilt. Flushing: The SSD cache pool is being flushed.
Health	The health of the pool: <ul style="list-style-type: none"> Good: The SSD cache pool is good. Failed: The SSD cache pool has failed. Degraded: The SSD cache pool is not healthy and not complete. The reason could be missing or failed SSDs.
Total	Total capacity of the SSD cache pool.
Cache Type	The SSD cache type: <ul style="list-style-type: none"> Disabled. Enabled.
RAID	The RAID level of the SSD cache pool:

	<ul style="list-style-type: none"> • NRAID+: SSD read cache. • NRAID 1+: SSD read-write cache.
Pool Name	Which pool the SSD cache pool assigns to.
I/O Type	The I/O type of the SSD cache pool: <ul style="list-style-type: none"> • Database. • File System. • Web Service. • Customization.

Table 10-6 SSDs Column Descriptions

Column Name	Description
No.	The number of the SSD or SSD group: <ul style="list-style-type: none"> • SSD Read Cache: The number of the SSD. • SSD Read-write Cache: The number of the SSD group.
Enclosure ID	The enclosure ID.
Slot	The position of the SSD.
Status	The status of the SSD: <ul style="list-style-type: none"> • Online: The SSD is online. • Missing: The SSD is missing in the pool. • Rebuilding: The SSD is being rebuilt. • Flushing: The SSD is being flushed.
Health	The health of the SSD: <ul style="list-style-type: none"> • Good: The disk drive is good. • Failed: The disk drive has failed. • Error Alert: S.M.A.R.T. error alerts. • Read Errors: The SSD has unrecoverable read errors.
Capacity	The capacity of the SSD.
Disk Type	The type of disk drive: <ul style="list-style-type: none"> • [SAS SSD SATA SSD] • [12.0Gb/s 6.0Gb/s 3.0Gb/s 1.5Gb/s]
Manufacturer	The manufacturer of the SSD.
Model	The model name of the SSD.

Table 10-7 Enabled Volume Column Descriptions

Column Name	Description
Volume Name	The volume is enabled SSD cache.
Status	The status of the volume:

	<ul style="list-style-type: none"> • Online: The volume is online. • Offline: The volume is offline. • Rebuilding: The volume is being rebuilt. • Flushing: The volume is being flushed.
Health	<p>The health of the volume:</p> <ul style="list-style-type: none"> • Optimal: the volume is working well and there is no failed disk in the RG. • Failed: the pool disk of the volume has single or multiple failed disks than its RAID level can recover from data loss. • Degraded: At least one disk from the pool of the volume has failed or plugged out. • Partially optimal: the volume has experienced recoverable read errors. After passing parity check, the health will become Optimal.
Capacity	The capacity of the volume.
Total Cache Used	The capacity of total cache used.
Write Cache Used	The capacity of write cache used.

10.3.4. Operations on SSD Cache Pools

The options are available in this tab:

Add or Remove SSDs

For an SSD read cache, click ▼ -> **Add / Remove SSDs** to add into or remove SSDs from the SSD cache pool. Check SSDs to add into the SSD cache pool, and uncheck SSDs to remove from the SSD cache pool.

Add / Remove SSDs

SSD Cache Pool

SSD Cache Pool Name : RCPool-1
 Cache Type : Read Cache (NRAID+)
 Capacity : 744.72 GB

Select SSDs

Check SSDs to add into the SSD cache pool, and uncheck SSDs to remove from the SSD cache pool.

Enclosure ID: 0 (Head Unit: XS5216) ▼

<input type="checkbox"/>	Enclosure ID	Slot	Health	Capacity	Disk Type	Manufacturer	Model
<input checked="" type="checkbox"/>	0	1	Good	372.36 GB	SAS SSD 12.0Gb/s	SEAGATE	ST400FM0053
<input checked="" type="checkbox"/>	0	2	Good	372.36 GB	SAS SSD 12.0Gb/s	SEAGATE	ST400FM0053
<input checked="" type="checkbox"/>	0	5	Good	744.96 GB	SAS SSD 12.0Gb/s	MICRON	S630DC-800
<input checked="" type="checkbox"/>	0	6	Good	744.96 GB	SAS SSD 12.0Gb/s	MICRON	S630DC-800
<input type="checkbox"/>	0	7	Good	744.96 GB	SAS SSD 12.0Gb/s	MICRON	S630DC-800
<input type="checkbox"/>	0	8	Good	744.96 GB	SAS SSD 12.0Gb/s	MICRON	S630DC-800

Figure 10-18 Add / Remove SSDs from the SSD Cache Pool

For an SSD read-write cache, click ▼ -> **Add SSDs** to add SSDs into the SSD cache pool. Please select two SSDs at a time to add into the SSD cache pool.

Add SSDs

SSD Cache Pool

SSD Cache Pool Name : RWCPool-2
 Cache Type : Read-write Cache (NRAID 1+)
 Capacity : 372.36 GB

Select SSDs

Please select two SSDs at a time to add into the SSD cache pool.

Enclosure ID: 0 (Head Unit: XS5216) ▼

<input checked="" type="checkbox"/>	Enclosure ID	Slot	Health	Capacity	Disk Type	Manufacturer	Model
<input checked="" type="checkbox"/>	0	7	Good	744.96 GB	SAS SSD 12.0Gb/s	MICRON	S630DC-800
<input checked="" type="checkbox"/>	0	8	Good	744.96 GB	SAS SSD 12.0Gb/s	MICRON	S630DC-800

Figure 10-19 Add SSDs into the SSD Cache Pool

Delete an SSD Cache Pool

Click ▼ -> **Delete** to delete the SSD cache pool. If deleting an SSD read-write cache pool, it will take times to flush data from SSDs to HDDs. The SSD cache pool will be deleted after flushed, otherwise the data may be corrupt.

More Information of the SSD Cache Pool

Click ▼ -> **More Information** to show the detail information of the SSD cache pool.

10.4. Monitor SSD Cache Statistics

This section will describe the monitoring of SSD cache statistics.

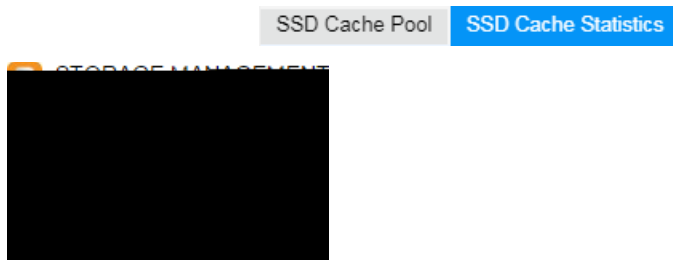

Figure 10-20 SSD Cache Function Submenu

Select the **SSD Cache Statistics** function tab in the **SSD Cache** function submenu to monitor the SSD cache statistics. Here is an example of monitoring the volume of the SSD read-write cache pool.

1. Select an **SSD Cache Pool Name** and select an **Enabled Volumes** which you want to monitor.

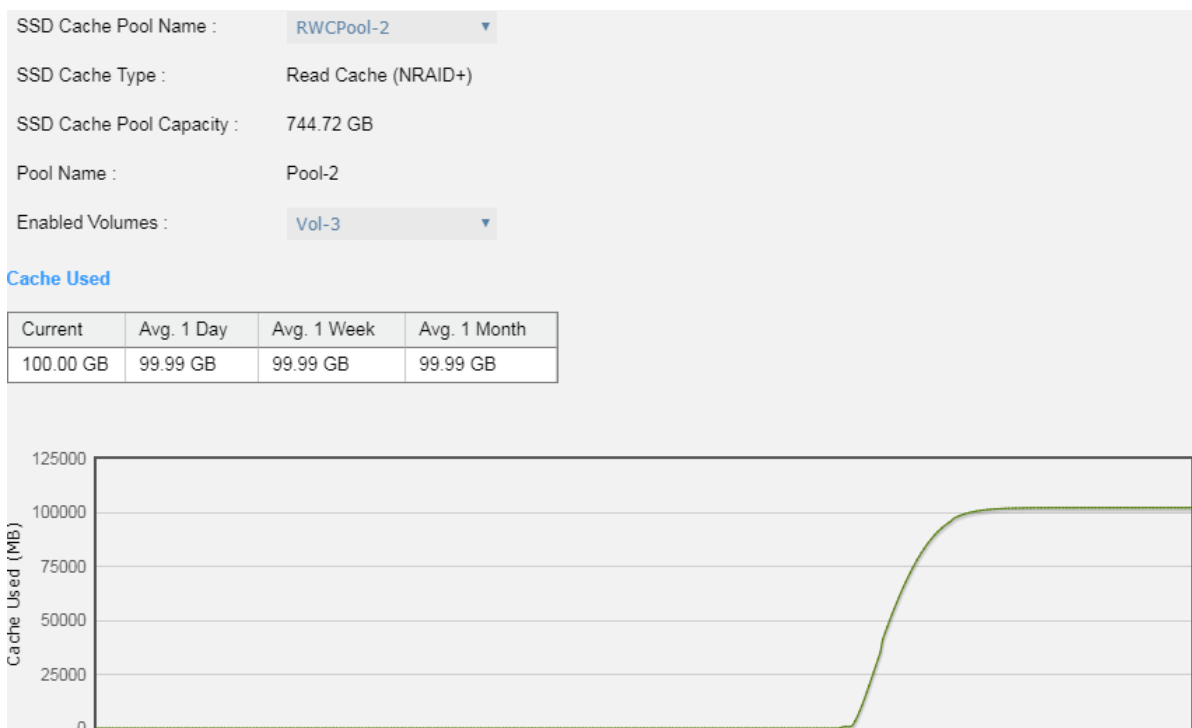



Figure 10-21 SSD Cache Statistics

2. The SSD cache statistics include **Cache Used**, **Cache Hits**, and **Cache Hit Ratio**. Each items have current value, average 1 day value, average 1 week value, and average 1 month value. The diagram displays the current value with 30 seconds refresh and total 4 hours.

Table 10-8 SSD Cache Statistics Descriptions

Column Name	Description
Cache Used	How much capacity of the SSD cache pool is used by the volume? Unit is MB, GB, or TB.
Cache Hits	How many cache hits occurred by the volume? Unit is the number of times
Cache Hit Ratio	How many cache hit ratio occurred by the volume? Unit is percentage.

10.5. SSD Cache Notices

The following are some notices about SSD cache.

- To support SSD cache 2.0, the resources will be redistributed. So executing COLD REBOOT is necessary after upgrade from firmware 1.0.x to 1.1.0.
- The SSD cache is optional; the SSD cache license can be extended to SSD cache 2.0 with read and write cache.
- The data structure of the SSD cache 2.0 is re-designed from the previous SSD cache. After upgrade to firmware 1.1.0 with SSD cache 2.0, you have to configure SSD cache again if you have already enabled SSD cache in firmware 1.0.x.

11. Auto Tiering

This chapter describes an overview and operations of auto tiering.

**INFORMATION:**

Auto tiering 2.0 with flexible RAID and disk configurations is available in SANOS firmware 1.2.0.

11.1. Overview

From the perspective of storage features, the performance of SSD is high, but the cost is also high per GB. Relatively speaking, the cost of traditional hard drive is low, so as performance is relatively poor. If we follow the 80/20 rule to configure storage systems, all-SSD configuration is unreasonable for all but the most intensive applications. In fact, SSD will be needed in only a small part for most typical applications, regardless of whether or not a critical application, thus giving SSD resources for general storage needs is hugely cost-prohibitive. Although traditional hard disk performance is enough for general applications which I/O requirements are not high, the traditional all-hard-drive configuration is also gradually been inadequate.

On the other hand, the data itself has a lifecycle. Since the data in the course of its life cycle, it has experienced different levels of activity. In common usage, when creating the data, it is usually used. As the age of the data increases, it is accessed less often.

The Solution

Therefore, to balance performance and cost factors, adapting hybrid storage architecture with a mixture of SSD and traditional HDD seems to be the most reasonable approach for modern IT environments. Generally, SSD-based storage capacity in 10 to 15% of the total storage capacity should be enough to fulfill the requirements of critical high I/O applications. An automated tiering pool is a simple and elegant solution for dynamically matching storage requirements with changes in the frequency of data access.

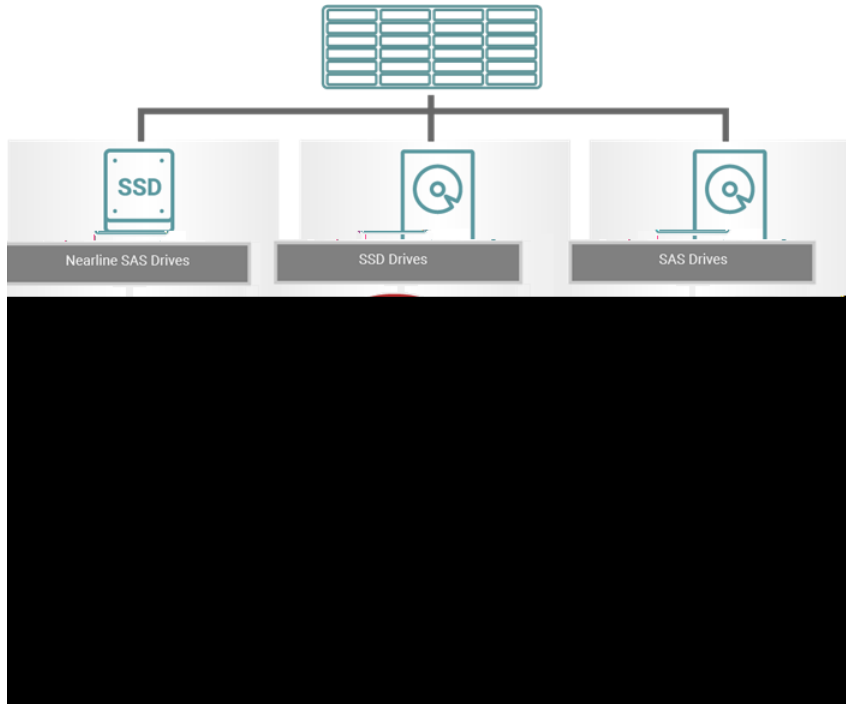

Figure 11-1 Auto Tiering Pool

11.1.1. Tier Categories

As the name suggestion, auto tiering must have two tiers at least. Automated tiering pool segregated disk drives into three categories for dual controllers and four for single controller.

- Tier 1: SSD drives for extreme performance tier
- Tier 2: SAS drives (15K or 10K RPM SAS HDD) for performance tier
- Tier 3: Nearline SAS drives (7.2K or lower RPM SAS HDD) for capacity tier
- Tier 4: SATA drives for capacity tier (for single controller only, not recommended)

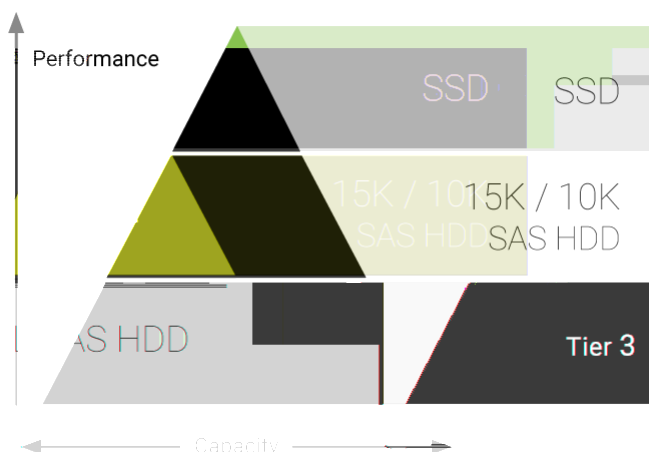

Figure 11-2 3 Levels of Tiered Storage

Tier 1 / SSD Tier / Extreme Performance Tier

Use the SSD tier when response time and performance are the most important criteria for storage. This tier uses flash technology that does not contain moving parts. This revolutionary technology eliminates the rotation latencies and can improve performance and save energy significantly.

Compared to traditional spinning drives, SSD drives have higher cost per gigabyte, but lower per IO cost. For the best practice, use the SSD drive to get data that requires fast response time and high IOPS. Auto tiering enables you to optimize the use of these high-performance resources because it automatically relocates "hot" data to the SSD tier.

Tier 2 / SAS HDD Tier / Performance Tier

Use the SAS HDD tier to achieve a combination of performance and capacity. The SAS HDD tier provides high levels of performance, reliability, and capacity. SAS HDD stores data on a series of fast rotating disks based on mechanical hard disk drive technology.

This tier includes 15K and 10K RPM spinning drives, which are valuable because it provides a high level performance with consistent response time, high throughput and good bandwidth at moderate price.

Tier 3 / NL-SAS HDD Tier / Capacity Tier

Use the NL-SAS HDD tier to reduce the cost per GB of data. This tier consists of 7.2K or lower RPM SAS HDD which is designed to achieve the maximum capacity at an appropriate performance level. While NL-SAS HDDs have slower speeds than SAS HDDs, NL-SAS HDDs

can significantly reduce power consumption and extend capacity in more expensive and higher performance storage tiers.

In a typical system, most of the application data has very little I/O activity. Because NL-SAS HDDs cost less per GB, they are the most appropriate media type for the "cold" data. NL-SAS HDDs consume less power than SAS HDDs and provide total cost of ownership improvement that take into purchase cost.

11.1.2. Flexible RAID and Disk Configurations

Auto Tiering 2.0 supports flexible RAID and disk configurations. You can create each tier (disk group) with different RAID level and different quantity of disk. For example, SSD tier uses 4 disks with RAID 10 for extreme performance, SAS tier uses 6 disks with RAID 6, and NL-SAS tier uses 8 disks with RAID 5 for capacity. This feature is very important for IT administrator to arrange storage plan flexibly.

The screenshot shows a 'RAID Configuration' window with the following settings:

- SSD Tier:** RAID Level: RAID 10, Quantity of Subgroups: 2, Quantity of SSD Disks: 4
- SAS Tier:** RAID Level: RAID 6, Quantity of SAS Disks: 6
- NL-SAS Tier:** RAID Level: RAID 5, Quantity of NL-SAS Disks: 8

Figure 11-3 Flexible RAID and Disk Configurations

11.2. Theory of Operation

Auto tiering is the automated progression or demotion of data across different tiers (types) of storage devices and media. The movement of data takes place in an automated way with the help of software and is assigned to the ideal storage media according to performance and capacity requirements. It also includes the ability to define rules and policies that

dictate if and when data can be moved between the tiers, and in many cases provides the ability to pin data to tiers permanently or for specific periods of time.

11.2.1. Auto Tiering Architecture

A newly created auto tiering pool is based on thin provisioning technology. Each tier works based on one or more disk groups. The following is the storage architecture of an auto tiering pool.

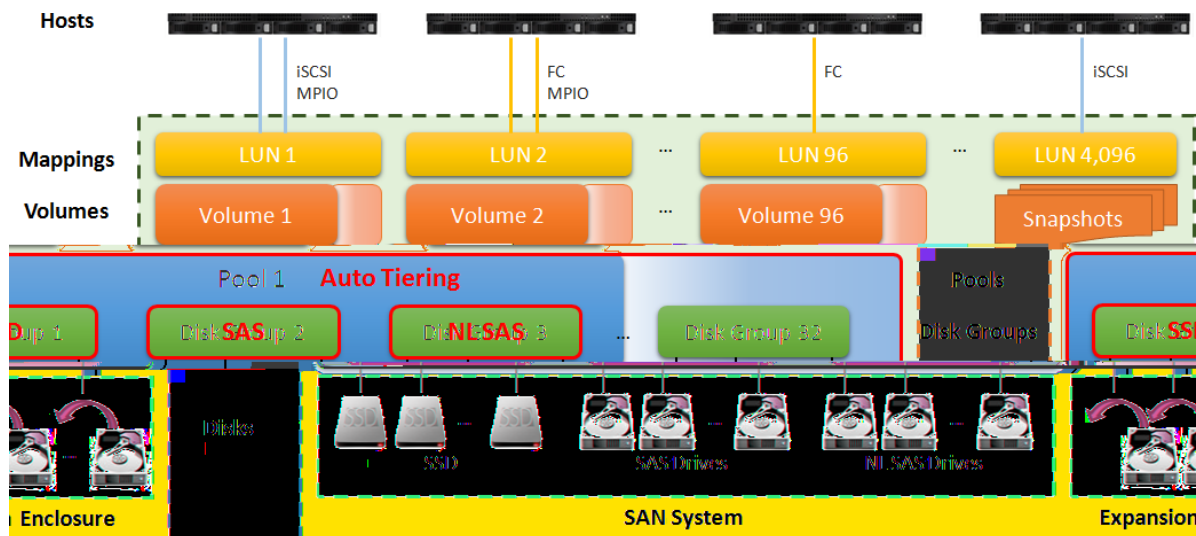

Figure 11-4 Storage Architecture of Auto Tiering Pool

To increase the capacity of an auto tiering pool, any tier (disk group) which contains either one tier of SSDs, SAS HDDs, or NL-SAS HDDs can be added to the pool any time. An auto tiering pool can have up to 32 disk groups with each disk group contains up to 64 disk drives. And the maximum disk drive quantity in a pool is 256. The maximum addressable capacity of each disk group is 64TB. So the maximum capacity in a system is 256TB. For more information about pool operation, please refer to the chapter 11.3, [Configuring Auto Tiering Pools](#) section.

Table 11-1 Auto Tiering Pool Parameters

Item	Value
Maximum disk group quantity in a pool	32
Maximum disk drive quantity in a disk group	64
Maximum RAID EE spare quantity in a disk group	8
Maximum disk drive quantity in a pool (include dedicated spares)	256
Maximum pool quantity per system	64
Maximum dedicated spare quantity in a pool	8
Maximum tiers (include SSD, SAS HDD, NL-SAS HDD)	3
Maximum addressable capacity of a disk group	64TB
Maximum addressable capacity of an auto tiering pool	256TB
Maximum addressable capacity of total auto tiering pools (include thin provisioning pools)	1,024TB
Provisioning granularity	1GB

By design, the auto tiering feature allows selecting policies that define how data are moved between different tiers, and in many cases provides the ability to pin data to tiers permanently or for specific periods of time.

Auto tiering storage is the assignment of different categories of data to different disk types. It operates based on relocating the most active data up to the highest available tier and the least active data down to the lowest tier. Auto tiering works based on an allocation unit (granularity) of 1GB and relocates data by moving the entire unit to the appropriate tier, depending on the tiering policy selected for that particular volume.

In order to ensure sufficient space in the higher tiers, 10% of the space is reserved in each higher tier to prepare for the data allocation for those tiering policies which would allocate initial space in highest available tiers. By reclaiming this 10% headroom, the least active units within each tier move to lower tiers. The whole mechanism of auto tiering contains three steps, statistic collection by accessed counts, ranking hotness data by the statistic collection, and then relocation data via ranking.

11.2.2. Intelligent Auto Tiering Mechanism

Auto tiering storage management system manages the data relocation and monitors the data hotness ratio using half-life coefficient and advanced ranking algorithm. It operates on three major functions.

Statistics Collection

The volume space is divided into units of equal size in which the hotness is collected and analyzed per hour. Activity level of a sub LUN is determined by counting the quantity of read and write access on the sub LUN. Logical volume manager maintains a cumulative I/O count and weights each I/O by how recently it arrived. The new coming I/O is given a full weight. After approximately 24 hours, the weight of this IO is nearly cut in half and continues to decrease. The reduction weight is processing per hour by our precision algorithm. This statistics collection occurs continuously in the background for auto tiering pool.

Ranking

This analysis produces a rank ordering of each sub LUN within the pool. Note that the policies of volumes would affect how sub LUNs are ranked.

After analysis, the system would generate following information for each tier:

- The amount of data to be moved up
- The amount of data to be moved down
- The amount of data to be moved into a tier.



INFORMATION:

The hotness analysis process which includes statistics collection and ranking may take minutes to complete.

Relocation

According to the hotness analysis, relocation is processed during the user-defined relocation window, which is the number of minutes given to the relocation process. When the window closes, the relocation process would stop relocating data. The other parameter is relocation rate which controls speed of the relocation process. Valid value of relocation rate is Fast, Medium, and Slow.

Auto tiering promotes sub LUNs according to the candidate list that it created in the analysis stage. During relocation, it prioritizes relocating sub LUNs to higher tiers. At the

same time, sub LUNs are only relocated to higher tiers if the space they occupy is required for a higher priority. Using the mechanism, auto tiering makes sure that the higher performing drives are always used.

During I/O, as data is written to a pool, auto tiering attempts to move it to the higher tiers if space is available and the tiering policy allows for it. As we describe before, the relocation process will keep 10% of the free space in all tiers. This space is reserved for any new allocations of higher priority sub LUNs before the next relocation. Lower tiers are used for capacity when needed. The entire relocation process is complete automatically based on the user-defined relocation schedule, or manually if user triggers by himself. The following figure provides an illustration of how auto tiering can improve sub LUN placement in a pool.

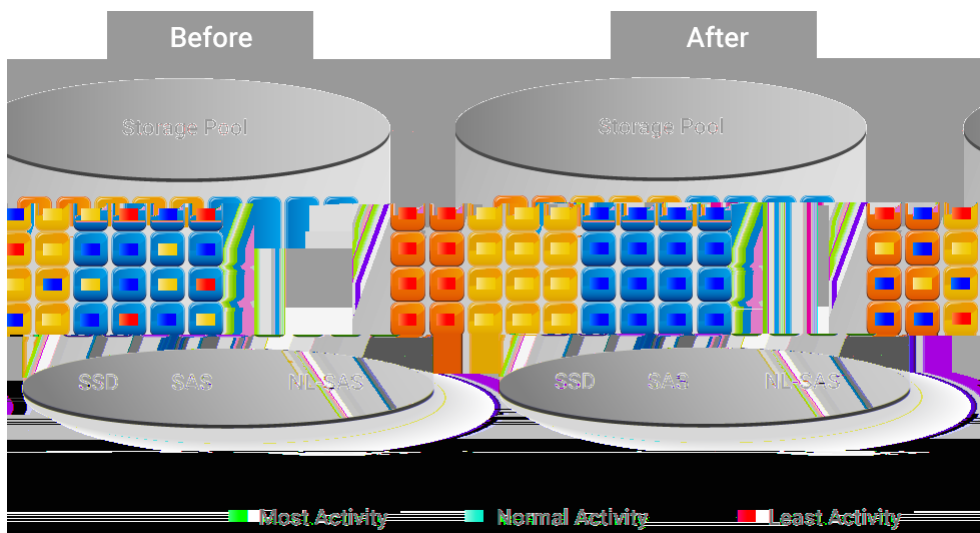

Figure 11-5 Auto Tiering Relocation

11.2.3. Tiering Policies

For a best performance in various environments, auto tiering has a completely automated feature that implements a set of tiering policies. Tiering policies determine how new allocations and ongoing relocations should apply within a volume for those requirements. Auto tiering uses an algorithm to make data relocation decisions based on the activity level of each unit. It ranks the order of data relocation across all volumes within each separate pool. The system uses this information in combination with the tiering policy per volume to create a candidate list for data movement. The following volume policies are available:

Auto Tiering (Default)

It allows moving a small percentage of the “hot” data to higher tiers while maintaining the rest of the data in the lower tiers. This policy automatically relocates data to the most appropriate tier based on the activity level of each data. Sub LUNs are relocated based on the highest performance disk drives available and its hotness. Although this setting relocates data based on the performance statistics of the volume, the volume sets with “Highest available Tier” take precedence. Initial space is allocated in the tier which is healthier and has more free capacity than other tiers, then relocated according to hotness of the data. This is the recommended policy and it is the default policy for each newly created volume.

Start Highest then Auto Tiering

This takes advantage of the both “Highest Available Tier” and “Auto Tiering” policies. “Start Highest then Auto Tiering” sets the preferred tier for initial data allocation to the highest performing disks with available space, and then it relocates the volume’s data based on the performance statistics and the auto-tiering algorithm. With this tiering policy, less active data is moved to lower tiers, making room for more active data in the higher tiers. Initial space is allocated in highest available tier first, then relocated according to hotness of the data.

Highest Available Tier

Use this policy when quick response times are a priority. This tier is effective for volumes which require high levels of performance whenever they are accessed. The policy starts with the “hottest” first and places them in the highest available tier until the tier’s capacity or performance capability limit is hit. Then it places the sub LUNs into the second higher tier. Initial space is allocated in highest available tier. Auto tiering would prioritize sub LUNs with highest available tier selected above all other settings.

Lowest Tier

Use this policy when cost effectiveness is the highest priority. With this policy, data is initially placed on the lowest available tier with capacity. Select this policy for volumes that are not performance sensitive or response-time sensitive. Regardless of their activity level, all sub LUN of these volumes will remain on the lowest storage tier available in their pool. Data of volumes with “Lowest tier” policy would always reside in the lowest tier. Changing policy of a volume with data in higher tiers to “Lowest tier” would cause all its data in higher tier to be relocated down to the lowest tier.

No Data Movement

If a volume is configured with this policy, no sub LUN provisioned to the volumes is relocated across tiers. Data remains in its current position, but can still be relocated within the tier. The system still collects statistics on these sub LUNs after the tiering policy is changed. Initial space is allocated in the tier which is healthier and has more free capacity than other tiers. No relocation would be performed in a volume which selects “No data movement” tiering policy.

The following table summarizes the tiering policies.

Table 11-2 Summary of Tiering Policies

Tiering Policy	Description
Auto Tiering	Sets the initial data placement to the optimized tier (disk group) and then relocates the data based on the statistics such that data is relocated among tiers according to the I/O activity.
Start Highest then Auto Tiering	First sets the preferred tier for the initial data placement to the highest tiers with available space, then relocates the data based on the statistics and the auto tiering algorithm.
Highest Available Tier	Sets the preferred tier for the initial data placement to the highest tiers with available space, and so as the succeeding data relocation.
Lowest Tier	Sets the preferred tier for the initial data placement to the lowest tiers with available space, and so as the succeeding data relocation.
No Data Movement	Sets the preferred tier for the initial data to the optimized tier, and retain the data without movement.

11.3. Configure Auto Tiering Pools

This section will describe the operations of configuring auto tiering pool.

Pools Auto Tiering

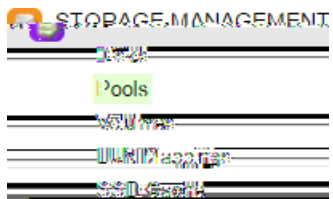

Figure 11-6 Pools Function Submenu

11.3.1. Enable Auto Tiering License

The auto tiering function is optional. Before using it, you have to enable auto tiering license. Select the **Update** function tab in the **Maintenance** function submenu, download **Request License** file and send to your local sales to obtain a License Key. After getting the license key, click the **Choose File** button to select it, and then click the **Apply** button to enable. When the license is enabled, please reboot the system. Each license key is unique and dedicated to a specific system. If you have already enabled, this option will be invisible.

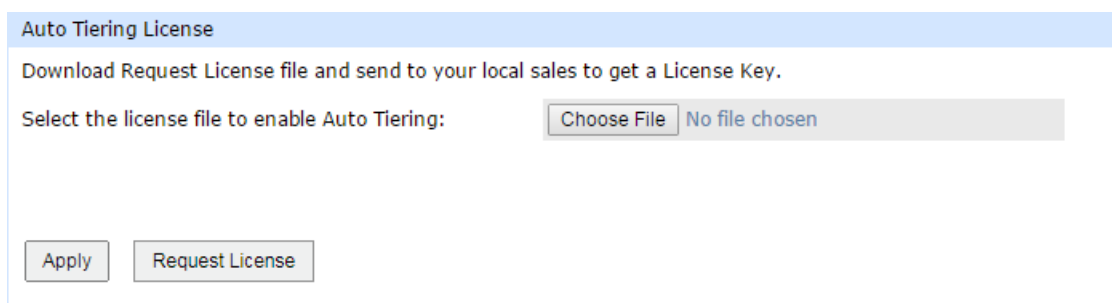

Figure 11-7 Enable Auto Tiering License

11.3.2. Create an Auto Tiering Pool

Here is an example of creating an auto tiering pool with 3 tiers, each tier has 3 disks configured in RAID 5. At the first time of creating an auto tiering pool, it may contain at least 2 tiers (disk groups) and the maximum quantity of disk in a tier (disk group) is 64.

1. Select the **Pools** function submenu, click the **Create Pool** button. It will scan available disks first.



TIP:

It may take 20 ~ 30 seconds to scan disks if your system has more than 200 disk drives. Please wait patiently.

Create Pool

General

- Disk Selection
- RAID Configuration
- Disk Properties
- Summary

Pool Type

Please select a pool type.

- Thick Provisioning
- Thin Provisioning
- Auto Tiering (Thin Provisioning Enabled)

Pool Properties

Please enter a pool name and select preferred controller setting.

Pool Name : ⓘ

Preferred Controller : ▾

The I/O resources will be managed by the preferred controller which you specified.

Enable SED

Enabling SED pool will use the secure SEDs to create a pool. Intermixing SEDs and non-SEDs are not supported in a pool.

Next Cancel

Figure 11-8 Create an Auto Tiering Pool Step 1

2. Select the **Pool Type** as Auto Tiering (Thin Provisioning Enabled). This option is available when auto-tiering license is enabled.
3. Enter a **Pool Name** for the pool. The maximum length of the pool name is 16 characters. Valid characters are [A~Z | a~z | 0~9 | -_<>].
4. Select a **Preferred Controller** from the drop-down list. The backend I/O resources in this pool will be processed by the preferred controller which you specified. This option is available when dual controllers are installed.
5. Check the **Enable SED Pool** checkbox. Enabling SED pool will use the secure SEDs to create a pool. Intermixing SEDs and non-SEDs are not supported in a pool.

6. Click the **Next** button to continue.

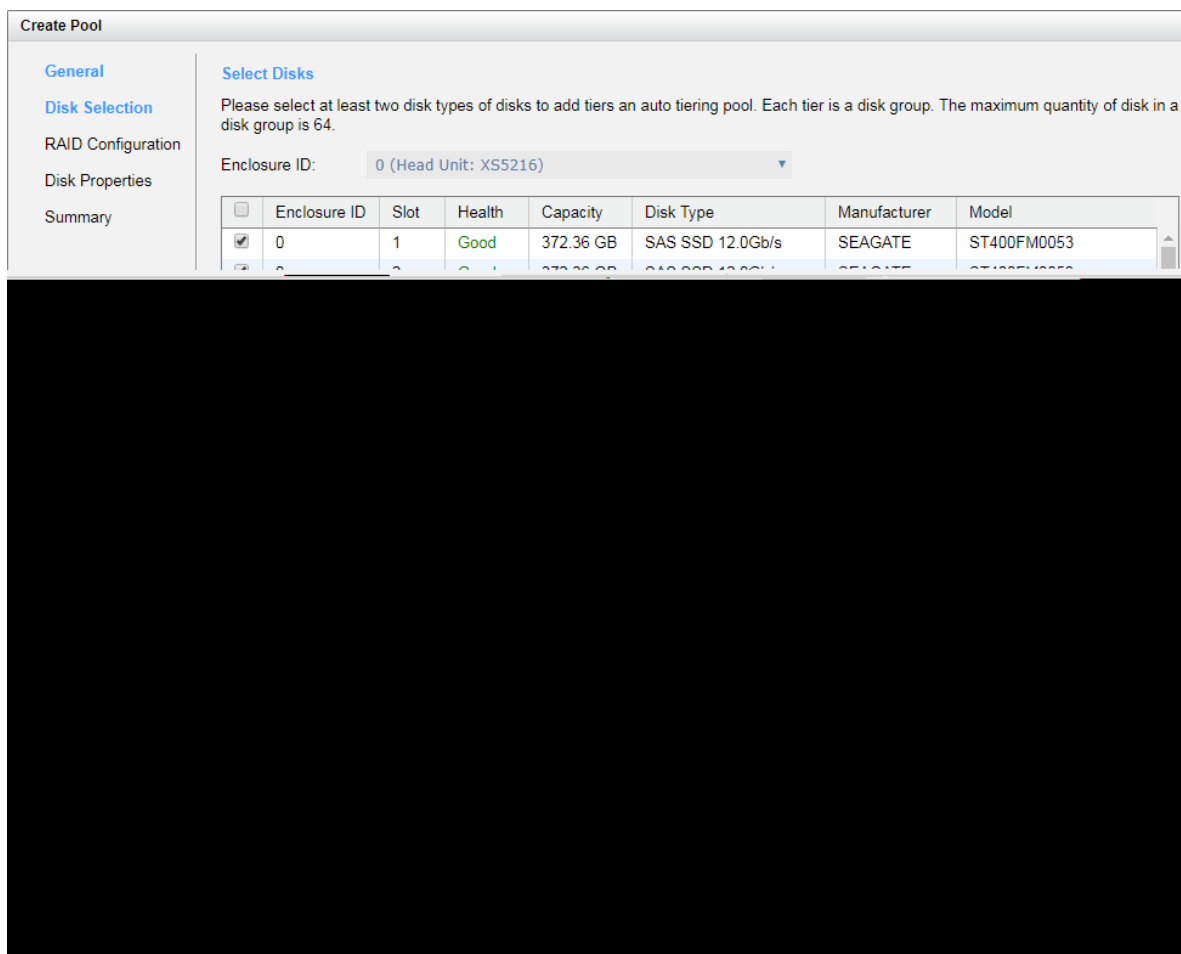

Figure 11-9 Create an Auto Tiering Pool Step 2

7. Please select disks for pool and select at least two disk types of disks to add tiers an auto tiering pool. Each tier is a disk group. The maximum quantity of disk in a disk group is 64. Select an **Enclosure ID** from the drop-down list to select disks from expansion enclosures.
8. Click the **Next** button to continue.

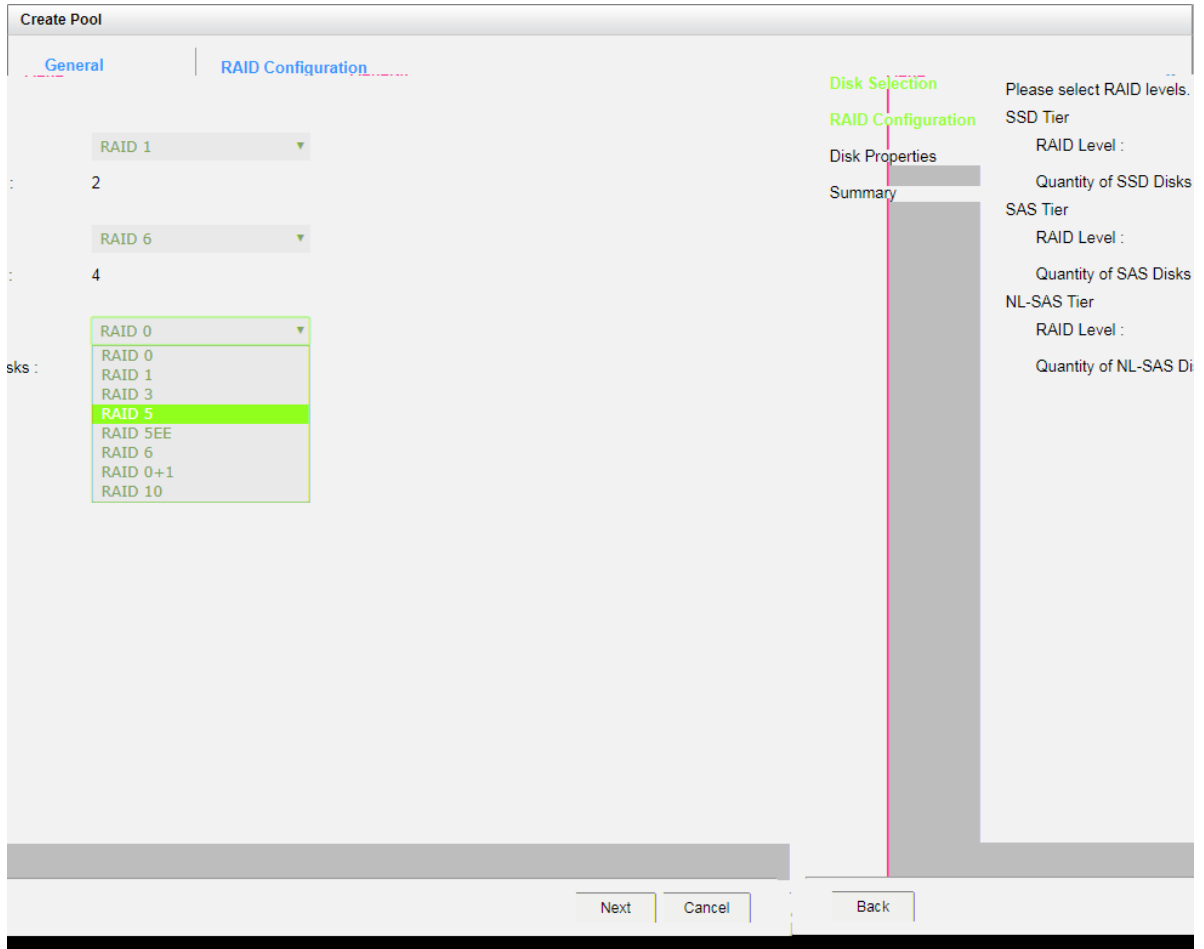

Figure 11-10 Create an Auto Tiering Pool Step 3

9. Select a **RAID Level** from the drop-down list which lists available RAID level only according to the disk selection for each tier. And also select a **Quantity of Subgroups** if the combination RAID level is selected.
10. Click the **Next** button to continue.

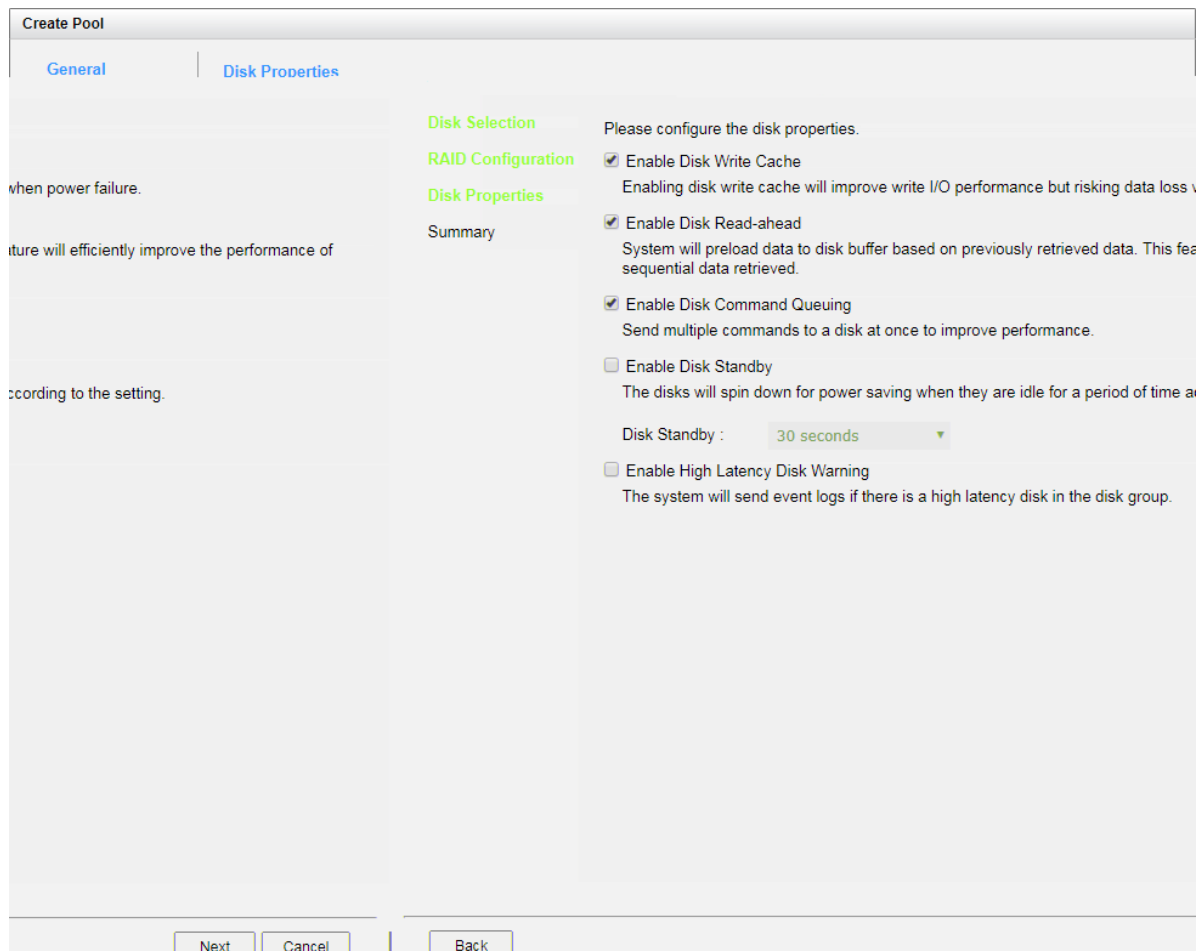

Figure 11-11 Create an Auto Tiering Pool Step 4

11. Disk properties can also be configured optionally in this step:

Enable Disk Write Cache: Check to enable the write cache option of disks. Enabling disk write cache will improve write I/O performance but have a risk of losing data when power failure.

Enable Disk Read-ahead: Check to enable the read-ahead function of disks. System will preload data to disk buffer based on previously retrieved data. This feature will efficiently improve the performance of sequential data retrieved.

Enable Disk Command Queuing: Check to enable the command queue function of disks. Send multiple commands to a disk at once to improve performance.

Enable Disk Standby: Check to enable the auto spin down function of disks. The disks will be spun down for power saving when they are idle for the period of time specified.

Enable High Latency Disk Warning: Check to enable the high latency disk warning function in a disk group. When a disk drive is abnormal with high latency, the system

will send event logs to notify IT administrators in advance to avoid affecting overall performance.

12. Click the **Next** button to continue.

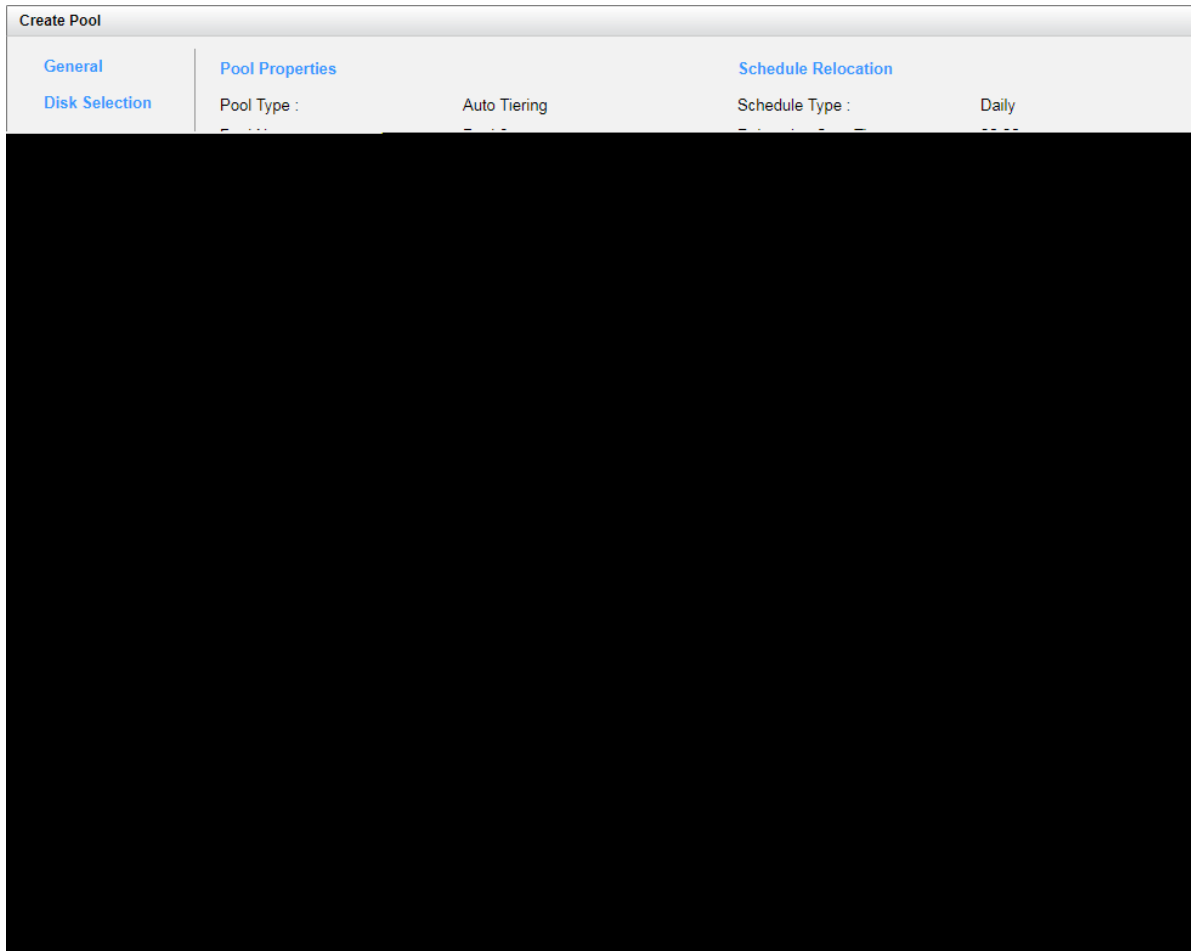

Figure 11-12 Create an Auto Tiering Pool Wizard Step 5

13. By default, we set relocation schedule at 00:00 daily, relocation period set to 00:00 which means let relocation process run until it finishes, and relocation rate to fast.

14. After confirmation at summary page, click the **Finish** button to create a pool.

	Pool Name	Status	Health	Total	Free	Available	Thin Provisioning	Auto Tiering	Volumes	Current Controller
▼	Pool-3	Online	Good	18.92 TB	18.92 TB	18.92 TB	Enabled	Enabled	0	Controller 1

Create Pool

Figure 11-13 An Auto Tiering Pool is Created

15. The pool has been created. If necessary, click the **Create Pool** button again to create others.



TIP:

Auto Tiering 2.0 supports flexible RAID and disk configurations. You can create each tier (disk group) with different RAID level and different quantity of disk. For example, SSD tier uses 4 disks with RAID 10 for extreme performance, SAS tier uses 6 disks with RAID 6, and NL-SAS tier uses 8 disks with RAID 5 for capacity.



CAUTION:

Because the auto tiering pool is based on thin provisioning technology, please always watch the system logs of thin provisioning pool. If the used capacity of the thin provisioning pool reaches 95% (default thin provisioning policy), the system will deactivate the pool to avoid data loss. So the host can't access the pool at this time. You have to expand the pool capacity, and then activate the pool to resolve the issue.

11.3.3. List Auto Tiering Pools

Pool View

Click a pool; it will display the related disk groups. Similarly, click a disk group; it will display the related disk drives. The pool properties can be configured by clicking the functions button ▼ to the left side of the specific pool.

Pool Name	Status	Health	Total	Free	Available	Thin Provisioning	Auto Tiering	Encryption	Volumes	Current Controller
Disk Groups										
No.	Status	Health	Total	Free	Tier Level	RAID	Disks Used	RAID EE Spares		
1	Online	Good	16.37 TB	16.37 TB	NL-SAS	RAID 5	4	N/A		
2	Online	Good	2.18 TB	2.18 TB	SAS	RAID 6	4	N/A		
3	Online	Good	371.00 GB	371.00 GB	SSD	RAID 1	2	N/A		
Disks										
Enclosure ID	Slot	Status	Health	Capacity	Disk Type	Manufacturer	Model			
0	1	Online	Good	372.36 GB	SAS SSD 12.0Gb/s	SEAGATE	ST400FM0053			
0	2	Online	Good	372.36 GB	SAS SSD 12.0Gb/s	SEAGATE	ST400FM0053			

Figure 11-14 List Auto Tiering Pools

This table shows the column descriptions.

Table 11-3 Pool Column Descriptions

Column Name	Description
Pool Name	The pool name.
Status	The status of the pool: <ul style="list-style-type: none"> • Online: The pool is online. • Offline: The pool is offline. • Rebuilding: The pool is being rebuilt. • Migrating: The pool is being migrated. • Relocating: The pool is being relocated. • EE Rebuilding: The pool is being RAID EE rebuilt.
Health	The health of the pool: <ul style="list-style-type: none"> • Good: The pool is good. • Failed: The pool has failed. • Degraded: The pool is unhealthy and incomplete. The cause may be a disk loss or failure.
Total	Total capacity of the pool.
Free	Free capacity of the pool.
Available	Available capacity of the pool.
Thin Provisioning	The status of Thin provisioning: <ul style="list-style-type: none"> • Disabled. • Enabled.
Auto Tiering	The status of Auto Tiering: <ul style="list-style-type: none"> • Disabled. • Enabled.

	<ul style="list-style-type: none"> • Not Supported: The pool contains the disk groups with mixed disk type.
Encryption	The Data Secure Mode: <ul style="list-style-type: none"> • Disabled: The pool is not encrypted. • Enabled: The pool is encrypted.
Volumes	The quantity of volumes in the pool.
Current Controller <i>(This option is only visible when dual controllers are installed.)</i>	The current running controller of the pool.

Table 11-4 Disk Group Column Descriptions

Column Name	Description
No	The number of disk group.
Status	The status of the disk group: <ul style="list-style-type: none"> • Online: The disk group is online. • Offline: The disk group is offline. • Rebuilding: The disk group is being rebuilt. • Migrating: The disk group is being migrated. • Relocating: The disk group is being relocated. • EE Rebuilding: The disk group is being RAID EE rebuilt.
Health	The health of the disk group: <ul style="list-style-type: none"> • Good: The disk group is good. • Failed: The disk group has failed. • Degraded: The disk group is not healthy and not completed. The reason could be lack of disk(s) or have failed disk.
Total	Total capacity of the disk group.
Free	Free capacity of the disk group.
RAID	The RAID level of the disk group.
Disks Used	The quantity of disk drives in the disk group.
RAID EE Spare	The quantity of RAID EE spare disk drives in the disk group. Traditional RAID level is display as N/A.

Table 11-5 Disk Column Descriptions

Column Name	Description
Enclosure ID	The enclosure ID.
Slot	The position of the disk drive.
Status	<p>The status of the disk drive:</p> <ul style="list-style-type: none"> • Online: The disk drive is online. • Missing: The disk drive is missing in the pool. • Rebuilding: The disk drive is being rebuilt. • Transitioning: The disk drive is being migrated or is replaced by another disk when rebuilding occurs. • Scrubbing: The disk drive is being scrubbed. • Check Done: The disk drive has been checked the disk health. • Copying Back: The disk drive is being copied back.
Health	<p>The health of the disk drive:</p> <ul style="list-style-type: none"> • Good: The disk drive is good. • Failed: The disk drive has failed. • Error Alert: S.M.A.R.T. error alerts. • Read Errors:

	Pool Name	Status	Health	Total	Free	Available	Volumes	Disks	Current Controller
▼	Pool-3	Online	Good	19.28 TB	18.25 TB	18.25 TB	5	12	Controller 1

Pool Tiering Status:

Tier Level	Tier Capacity (GB)	Tier Used (GB)	Move Up (GB)	Move Down (GB)	Move In (GB)	Tier Status
SSD	742	669	0	0	0	
SAS	2230	383	0	0	0	
NL-SAS	16765	2	0	0	0	

Figure 11-15 Auto Tiering Pools and Status

This table shows the column descriptions.

Table 11-6 Pool Tiering Status Column Descriptions

Column Name	Description
Tier Level	Tier categories, there are SSD, SAS, Nearline SAS, and SATA. The system will hide the tiers without any disk groups.
Tier Capacity	Total capacity of the tier.
Tier Used	Used capacity of the tier.
Move Up	The capacity prepares to move up to higher tier.
Move Down	The capacity prepares to move down to lower tier.
Move In	The capacity prepares to move in from other tiers.
Tier Status	Bar chart to show the tier status: <ul style="list-style-type: none"> • Light Blue: Used capacity. • Orange: The data will move in. • Gray: Unallocated.

11.3.4. Operations on Auto Tiering Pools

Most operations are described in the Configuring Storage Pools section. For more information, please refer to the chapter 8.4.3, [Operations on Thick Provisioning Pools](#) section and the chapter 9.3.3, [Operations on Thin Provisioning Pools](#) section. We describe the operations about auto tiering in the following.

Schedule Relocation

Click ▼ -> **Schedule Relocation** to setup the relocation schedule in auto tiering pool. If the **Relocation Period** sets as 00:00, it will let relocation process run until it finishes.

Schedule Relocation

Pool Name : Pool-3

Frequency : Daily
 Weekly
 Repeat Every 12 Hours

Relocation Start Time (hh:mm) : 00:00

Relocation Period (hh:mm) : 00 : 00 (Set as 00:00 to let relocation process run until it finishes.)

Relocation Rate : Fast

OK Cancel

Figure 11-16 Relocation Schedule

Relocate Now

Click ▼ -> **Relocate Now** to perform relocation right now in an auto tiering pool. Similarly, if **Relocation Period** sets as 00:00, it will let relocation process run until it finishes.

Relocate Now

Pool Name : Pool-3

Relocation Period (hh:mm) : 00 : 00 (Set as 00:00 to let relocation process run until it finishes.)

Relocation Rate : Fast

OK Cancel

Figure 11-17 Relocate Now

Stop Relocation

Click ▼ -> **Stop Relocation** to stop relocation when there is a relocation process in an auto tiering pool. The task that is being relocated will stop until it completes.

11.3.5. Add a Tier (Disk Group) in an Auto Tiering Pool

The **Add Disk Group** function adds a disk group to a pool to increase the capacity.

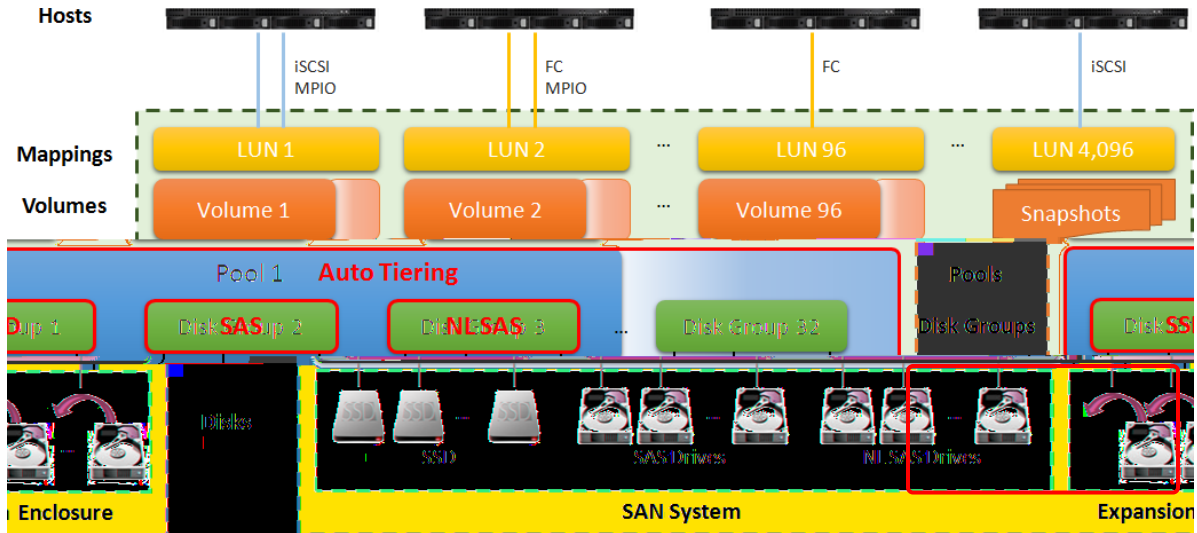

Figure 11-18 Add a Disk Group in an Auto Tiering Pool

Here is an example of adding a disk group in this provisioning pool.

1. Select a pool, click ▼ -> **Add Disk Group** to add a disk group in the auto tiering pool.

Add Disk Group

Pool Type

Thin Provisioning : Enabled
 Auto Tiering : Enabled

RAID Level

Please select a RAID level.

RAID Level : RAID 10 ▼
 Quantity of Subgroups : 2 ▼

Select Disks

Please select disks to add a disk group. The maximum quantity of disk in a disk group is 64.

Enclosure ID : 0 (Head Unit: XS5216) ▼

<input type="checkbox"/>	Enclosure ID	Slot	Health	Capacity	Disk Type	Manufacturer	Model
<input type="checkbox"/>	0	3	Good	372.36 GB	SAS SSD 12.0Gb/s	SEAGATE	ST400FM0053
<input type="checkbox"/>	0	4	Good	372.36 GB	SAS SSD 12.0Gb/s	SEAGATE	ST400FM0053

Figure 11-19 Add Disk Group

2. Select a **RAID Level** from the drop-down list and also select a **Quantity of Subgroups** if the combination RAID level is selected.
3. Please select disks to add a disk group. The maximum quantity of disk in a disk group is 64. Select an **Enclosure** from the drop-down list to select disks from the expansion enclosures.
4. Click the **OK** button to add a disk group.

11.3.6. Hot Spares in an Auto Tiering Pool

In an auto tiering pool, hot spare drives can only replace the drives of the same disk type. For example, a SSD tier can only be assigned SSD type drives as hot spare drives.

Enclosure ID: 0 (Head Unit: XS5216) ▾

<< first < prev 1 next > last >>

	Slot	Status	Health	Encryption	SED / ISE Status	Capacity	Disk Type	Usage	Pool Name	Manufacturer	Model
▼	1	Online	Good	None	N/A	372.36 GB	SAS SSD 12.0Gb/s	RAID	Pool-3	SEAGATE	ST400FM0053
▼	2	Online	Good	None	N/A	372.36 GB	SAS SSD 12.0Gb/s	RAID	Pool-3	SEAGATE	ST400FM0053
▼	3	Online	Good	None	N/A	372.36 GB	SAS SSD 12.0Gb/s	Dedicated Spare	Pool-3	SEAGATE	ST400FM0053
▼	4	Online	Good	None	N/A	372.36 GB	SAS SSD 12.0Gb/s	Free		SEAGATE	ST400FM0053
▼	5	Online	Good	None	N/A	744.96 GB	SAS SSD 12.0Gb/s	RAID	Pool-3	MICRON	S630DC-800
▼	6	Online	Good	None	N/A	744.96 GB	SAS SSD 12.0Gb/s	RAID	Pool-3	MICRON	S630DC-800
▼	7	Online	Good	None	N/A	744.96 GB	SAS SSD 12.0Gb/s	RAID	Pool-3	MICRON	S630DC-800
▼	8	Online	Good	None	N/A	744.96 GB	SAS SSD 12.0Gb/s	RAID	Pool-3	MICRON	S630DC-800
▼	9	Online	Good	None	N/A	1.09 TB	SAS HDD 12.0Gb/s	RAID	Pool-3	SEAGATE	ST1200MM0088
▼	10	Online	Good	None	N/A	1.09 TB	SAS HDD 12.0Gb/s	RAID	Pool-3	SEAGATE	ST1200MM0088
▼	11	Online	Good	None	N/A	1.09 TB	SAS HDD 12.0Gb/s	RAID	Pool-3	SEAGATE	ST1200MM0088
▼	12	Online	Good	None	N/A	1.09 TB	SAS HDD 12.0Gb/s	RAID	Pool-3	SEAGATE	ST1200MM0088
▼	13	Online	Good	None	N/A	5.46 TB	NL-SAS HDD 12.0Gb/s	RAID	Pool-3	SEAGATE	ST6000NM0014
▼	14	Online	Good	None	N/A	5.46 TB	NL-SAS HDD 12.0Gb/s	RAID	Pool-3	SEAGATE	ST6000NM0014
▼	15	Online	Good	None	N/A	5.46 TB	NL-SAS HDD 12.0Gb/s	RAID	Pool-3	SEAGATE	ST6000NM0014
▼	16	Online	Good	None	N/A	5.46 TB	NL-SAS HDD 12.0Gb/s	RAID	Pool-3	SEAGATE	ST6000NM0014

<< first < prev 1 next > last >>

Figure 11-20 Hot Spares in Auto Tiering Pool

11.4. Configure Volumes

This section will describe the operations of configuring volume in auto tiering pool.

11.4.1. Create a Volume in an Auto Tiering Pool

Here is an example of creating a volume in an auto tiering pool.

1. Select the **Volumes** function submenu, click the **Create Volume** button.

The screenshot shows a 'Create Volume' window with a sidebar on the left containing 'General', 'Advanced', and 'Summary'. The main area is titled 'Volume General Settings' and contains the following fields:

- Volume Name :** A text input field containing 'Vol-3' with an information icon to its right.
- Pool Name :** A dropdown menu showing 'Pool-3' with a downward arrow, and '(Available : 262144 GB)' to its right.
- Capacity :** A text input field containing '100' and a unit dropdown menu showing 'GB' with a downward arrow.
- Volume Type :** A dropdown menu showing 'RAID Volume' with a downward arrow.

Below the 'Volume Type' dropdown, there is a note: 'Select RAID Volume for general RAID usage or Backup Volume for backup usage such as the target volume of local clone or remote replication.'

At the bottom right of the window, there are two buttons: 'Next' and 'Cancel'.

Figure 11-21 Create a Volume of Auto Tiering Pool Step 1

2. Enter a **Volume Name** for the pool. The maximum length of the volume name is 32 characters. Valid characters are [A~Z | a~z | 0~9 | -_<>].
3. Select a **Pool Name** from the drop-down list. It will also display the available capacity of the pool.
4. Enter required **Capacity**. The unit can be selected from the drop-down list.
5. Select **Volume Type**. The options are **RAID Volume** (for general RAID usage) and **Backup Volume** (for the target volume of local clone or remote replication).
6. Click the **Next** button to continue.

Figure 11-22 Create a Volume of Auto Tiering Pool Step 2

7. Volume advanced settings can also be configured optionally in this step:

Stripe Size: The options are 64KB to 1,024KB.

Block Size: The options are 512Bytes to 4,096Bytes.

Background I/O Priority: The options are High, Medium, and Low. It will influence volume initialization, rebuild, and migration.

Tiering Policy: The options are Auto Tiering, Start Highest then Auto Tiering, High Available Tier, Lowest Tier, and No Data Movement. Please refer to the chapter 11.2.3, [Tiering Policies](#) section for detail.

Enable Cache Mode (Write-back Cache): Check to enable cache mode function of volume. Write back optimizes the system speed but comes with the risk where the data may be inconsistent between cache and disks in one short time interval.

Enable Video Editing Mode: Check to enable video editing mode function. It is optimized for video editing usage. Please enable it when your application is in video editing environment. Throes with th gh, Me46BT influence

Enable Space Reclamation: Check to enable the space reclamation function of the volume when the pool is auto tiering.



INFORMATION:

Stripe sizes from 64KB to 1,024KB support more than 8GB of memory for resource allocation. 4GB memory is only support 64KB stripe size.

8. Click the **Next** button to continue.

Create Volume

<p>General</p> <p>Advanced</p> <p>Summary</p>	<p>Configure Volume General Settings</p> <p>Volume Name : Vol-3</p> <p>Pool Name : Pool-3</p> <p>Capacity : 100 GB</p> <p>Volume Type : RAID Volume</p> <p>Configure Volume Advanced Settings</p> <p>Stripe Size : 64 KB</p> <p>Block Size : 512 Byte</p> <p>Background I/O Priority : High</p> <p>Tiering Policy : Auto Tiering</p>
---	--

Figure 11-23 Create a Volume of Auto Tiering Pool Step 3

9. After confirmation at summary page, click **Finish** button to create a volume.
10. The volume has been created. It will be initialized in protection RAID level (e.g., RAID 1, 3, 5, 6, 0+1, 10, 30, 50, and 60).

<< first < prev 1 next > last >>

	Volume Name	Status	Health	Capacity	Volume Type	SSD Cache	Snapshot Space	Snapshots	Clone	Write	Pool Name
▼	Vol-3	Online	Optimal	100.00 GB	RAID Volume	Disabled	0 MB / 0 MB	0	N/A	WB	Pool-3

<< first < prev 1 next > last >>

Create Volume Local Clone Options

Figure 11-24 A Volume in Auto Tiering Pool is Created

11. A volume has been created. If necessary, click the **Create Volume** button to create another.



INFORMATION:

SANOS supports instant RAID volume availability. The volume can be used immediately when it is initializing or rebuilding.



TIP:

If the pool contains some disk drives of 4Kn type, it is not available to set 512, 1024, or 2048 block size. When the case happens, it will pop up a warning message and suggest changing the block size to 4096.

11.4.2. List Volumes and Operations on Volumes

Most operations are described in the chapter 8.5, [Configuring Volumes](#) section. For more information about list volume, please refer to the chapter 8.5.2, [List Volumes](#) section. For more information about operations on volumes, please refer to the chapter 8.5.3, [Operations on Volumes](#) section. We describe auto tiering operations below.

Change Volume Properties

Click ▼ -> **Change Volume Properties** to change the volume properties of the volume.

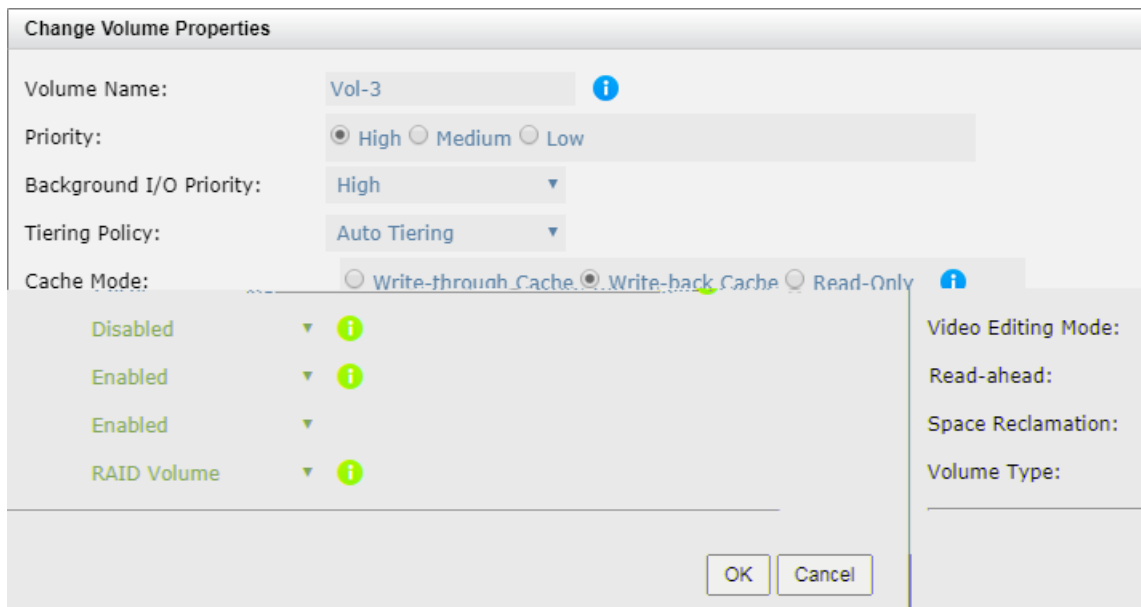

Figure 11-25 Change Volume Properties

Reclaim Space with Thin Provisioning Pool

Click ▼ -> **Space Reclamation** to reclaim space from the volume when the volume is in an auto tiering pool. For more information about space reclamation, please refer to the chapter 9.2.2, [Space Reclamation](#) section.

11.5. Configure LUN Mappings and Connect by Host Initiator

Next step you can configure LUN mapping and connect by host initiator. For more information about LUN mapping, please refer to the chapter 8.6, [Configure LUN Mappings](#) section for detail. For more information about host initiator, please refer to the chapter 8.7, [Connect by Host Initiator](#) section for detail.

11.6. Transfer to Auto Tiering Pool

This section describes thick provisioning pool or thin provisioning pool transfer to auto tiering one. If auto tiering license is enabled, the thick or thin provisioning pool without disk group of mixed disk type can be transferred to the auto tiering pool by **Add Disk Group** option.

Also note that the thick provisioning pool is preconfigured the space, after transferring to the auto tiering, the original disk group in the thick provisioning pool will be the lowest tier. When auto tiering mechanism is running, the hot data are copied to higher tier, but still occupy the space of the original block. If the data is cold, it will return to the original block space. So the total capacity of the pool does not change even adding the capacity of higher tiers.

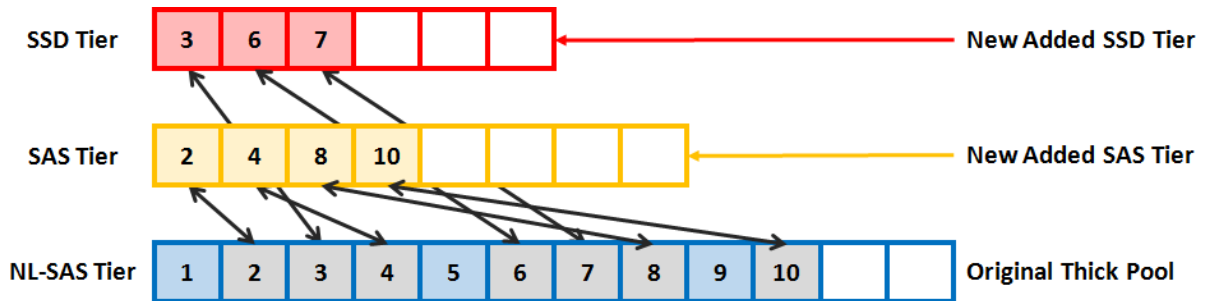

Figure 11-26 Block Map of Thick Provisioning Pool Transferring to Auto Tiering

Thin provisioning is dynamic allocation of space, if the hot data is moved up to the higher tier; it will release the original block space. So the total capacity is the sum of all tiers.

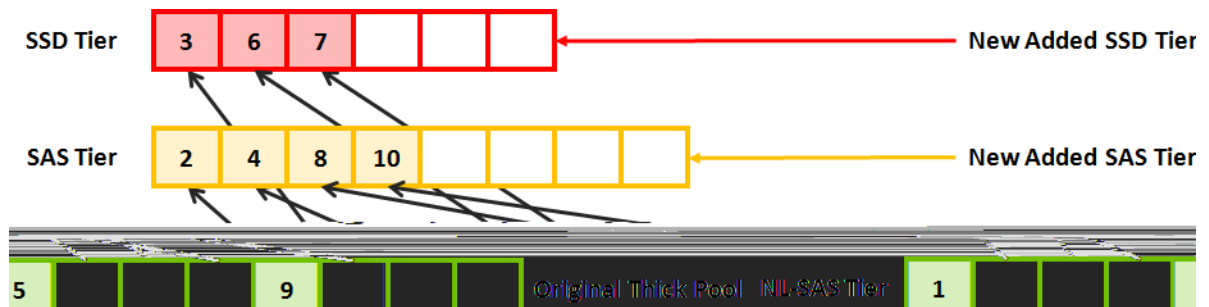

Figure 11-27 Block Map of Thin Provisioning Pool Transferring to Auto Tiering



CAUTION:

The action of transferring to auto tiering is irreversible. Consider all possible consequences before making this change.

11.6.1. Transfer from Thick Provisioning Pool to Auto Tiering

First of all, make sure the auto tiering license is enabled. For more information about enabling license operation, please refer to the chapter 11.3.1, [Enable Auto Tiering License](#) section. And then use **Add Disk Group** function to add another tier (disk group). Here is an example of transfer thick provisioning pool to auto tiering one.

1. Create a thick provisioning pool with SAS disk drives. **Auto Tiering** status is **Disabled**.

	Pool Name	Status	Health	Total	Free	Available	Thin Provisioning	Auto Tiering	Encryption	Volumes	Current Controller
▼	Pool-1	Online	Good	3.27 TB	3.27 TB	3.27 TB	Disabled	Disabled	Disabled	0	Controller 1
▼	Pool-2	Online	Good	16.37 TB	16.37 TB	16.37 TB	Enabled	Disabled	Disabled	0	Controller 1

Disk Groups								
	No.	Status	Health	Total	Free	RAID	Disks Used	RAID 2.0 Spare
▼	1	Online	Good	3.27 TB	3.27 TB	RAID 5	4	N/A

Disks							
Enclosure ID	Slot	Status	Health	Capacity	Disk Type	Manufacturer	Model
0	9	Online	Good	1.09 TB	SAS HDD 12.0Gb/s	SEAGATE	ST1200MM0088
0	10	Online	Good	1.09 TB	SAS HDD 12.0Gb/s	SEAGATE	ST1200MM0088
0	11	Online	Good	1.09 TB	SAS HDD 12.0Gb/s	SEAGATE	ST1200MM0088
0	12	Online	Good	1.09 TB	SAS HDD 12.0Gb/s	SEAGATE	ST1200MM0088

Figure 11-28 Transfer Thick Provisioning Pool to Auto Tiering Step 1

2. Click ▼ -> **Add Disk Group** to transfer from a thick provisioning pool to an auto tiering pool. Select **Enabled** from the Auto Tiering drop-down list. The tier (disk group) must be added one at a time. Select the **RAID Level** and **Select Disks**, and then click the **OK** button.

Add Disk Group

Pool Type

Thin Provisioning : Disabled

Auto Tiering : Disabled ▼ ⓘ

RAID Level

Please select a RAID level.

RAID Level : RAID 1 ▼

Select Disks

Please select disks to add a disk group. The maximum quantity of disk in a disk group is 64.

Enclosure ID : 0 (Head Unit: XS5216) ▼

<input type="checkbox"/>	Enclosure ID	Slot	Health	Capacity	Disk Type	Manufacturer	Model
<input checked="" type="checkbox"/>	0	1	Good	372.36 GB	SAS SSD 12.0Gb/s	SEAGATE	ST400FM0053
<input checked="" type="checkbox"/>	0	2	Good	372.36 GB	SAS SSD 12.0Gb/s	SEAGATE	ST400FM0053
<input type="checkbox"/>	0	3	Good	372.36 GB	SAS SSD 12.0Gb/s	SEAGATE	ST400FM0053
<input type="checkbox"/>	0	4	Good	372.36 GB	SAS SSD 12.0Gb/s	SEAGATE	ST400FM0053
<input type="checkbox"/>	0	5	Good	744.96 GB	SAS SSD 12.0Gb/s	MICRON	S630DC-800
<input type="checkbox"/>	0	6	Good	744.96 GB	SAS SSD 12.0Gb/s	MICRON	S630DC-800
<input type="checkbox"/>	0	7	Good	744.96 GB	SAS SSD 12.0Gb/s	MICRON	S630DC-800
<input type="checkbox"/>	0	8	Good	744.96 GB	SAS SSD 12.0Gb/s	MICRON	S630DC-800

Figure 11-29 Transfer Thick Provisioning Pool to Auto Tiering Step 2

3. Use the same procedure to add another tier if necessary.

	Pool Name	Status	Health	Total	Free	Available	Thin Provisioning	Auto Tiering	Encryption	Volumes	Current Controller
▼	Pool-1	Online	Good	3.27 TB	3.27 TB	3.27 TB	Disabled	Enabled	Disabled	0	Controller 1
▼	Pool-2	Online	Good	16.37 TB	16.37 TB	16.37 TB	Enabled	Disabled	Disabled	0	Controller 1

Disk Groups

	No.	Status	Health	Total	Free	Tier Level	RAID	Disks Used	RAID 2.0 Spare
▼	1	Online	Good	3.27 TB	3.27 TB	SAS	RAID 5	4	N/A
▼	2	Online	Good	372.00 GB	372.00 GB	SSD	RAID 1	2	N/A

Disks

Enclosure ID	Slot	Status	Health	Capacity	Disk Type	Manufacturer	Model
0	1	Online	Good	372.36 GB	SAS SSD 12.0Gb/s	SEAGATE	ST400FM0053
0	2	Online	Good	372.36 GB	SAS SSD 12.0Gb/s	SEAGATE	ST400FM0053

Create Pool

Figure 11-30 Transfer Thick Provisioning Pool to Auto Tiering Step 3

- Auto Tiering** status is **Enabled**. The thick provisioning pool has been transferred to auto tiering.



CAUTION:

The total capacity of the pool does not change even adding the capacity of higher tiers.

The action of transferring from the thick provisioning pool to auto tiering is irreversible. Please consider carefully all possible consequences before taking this step.

11.6.2. Transfer from Thin Provisioning Pool to Auto Tiering

First of all, make sure the auto tiering license is enabled. For more information about enabling license operation, please refer to the chapter 11.3.1, [Enable Auto Tiering License](#) section. And then use **Add Disk Group** function to add another tier (disk group). Here is an example of transfer thin provisioning pool to auto tiering one.

- Create a thin provisioning pool with NL-SAS disk drives. **Auto Tiering** status is **Disabled**.

TB	3.27 TB	Disabled	Enabled	Disabled	0	Controller 1	▼	Pool-1	Online	Good	3.27 TB	3.27 TB
TB	16.37 TB	Enabled	Disabled	Disabled	0	Controller 1	▼	Pool 2	Online	Good	16.37 TB	16.37 TB

RAID	Disks Used	RAID 2.0 Spare
RAID 5	4	N/A

Disk Type	Manufacturer	Model
-SAS HDD 12.0Gb/s	SEAGATE	ST6000NM0014
-SAS HDD 12.0Gb/s	SEAGATE	ST6000NM0014
-SAS HDD 12.0Gb/s	SEAGATE	ST6000NM0014
-SAS HDD 12.0Gb/s	SEAGATE	ST6000NM0014

Disk Groups						
	No.	Status	Health	Total	Free	
▼	1	Online	Good	16.37 TB	16.37 TB	

Disks						
Enclosure ID	Slot	Status	Health	Capacity	Dis	
0	13	Online	Good	5.46 TB	NL	
0	14	Online	Good	5.46 TB	NL	
0	15	Online	Good	5.46 TB	NL	
0	16	Online	Good	5.46 TB	NL	

Create Pool

Figure 11-31 Transfer Thin Provisioning Pool to Auto Tiering Step 1

- Click ▼ -> **Add Disk Group** to transfer from a thin provisioning pool to an auto tiering pool. Select **Enabled** from the Auto Tiering drop-down list. The tier (disk group) must be added one at a time. Select the **RAID Level** and **Select Disks**, and then click the **OK** button.

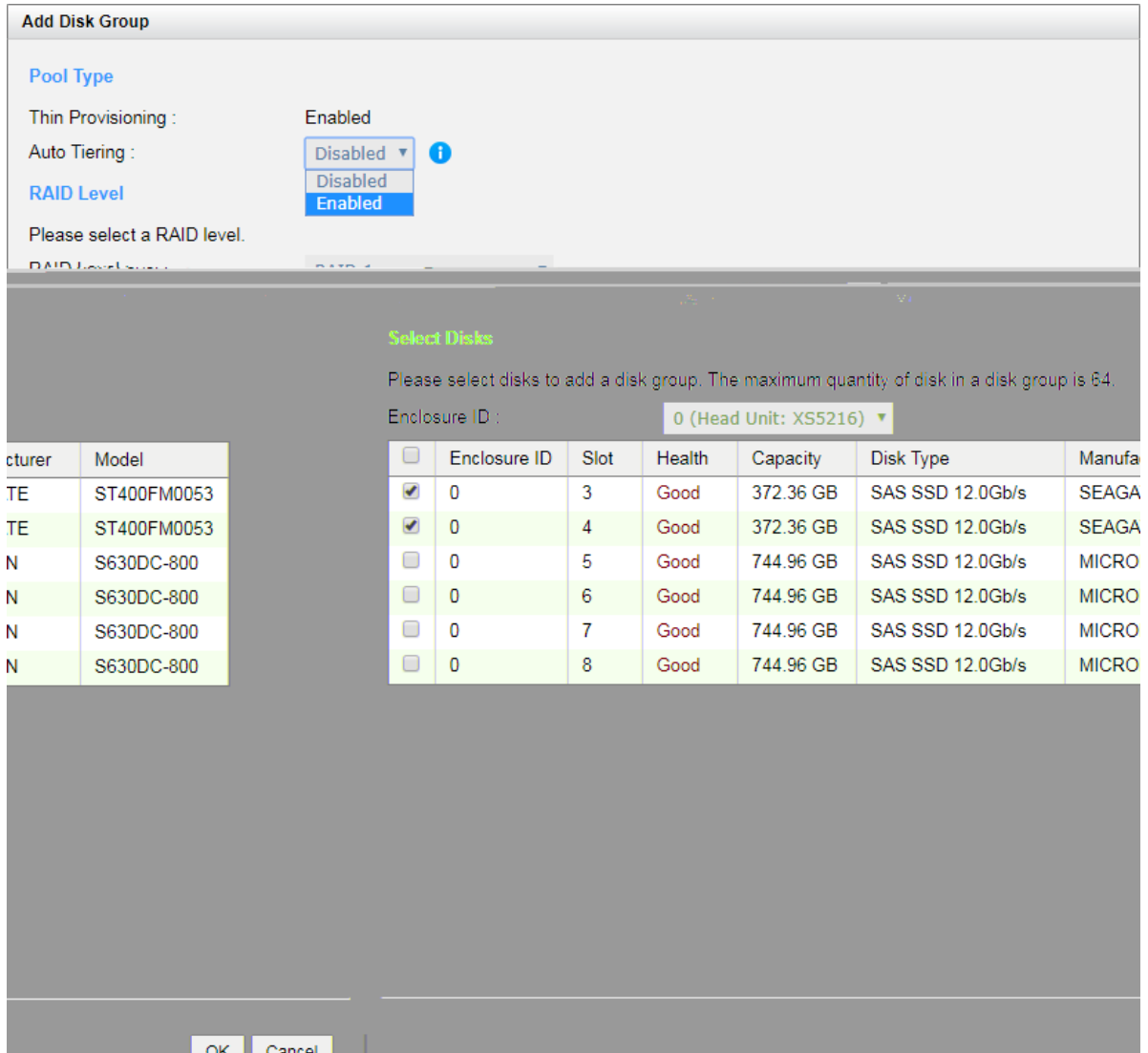

Figure 11-32 Transfer Thin Provisioning Pool to Auto Tiering Step 2

3. Use the same procedure to add another tier if necessary.

Pool Name	Status	Health	Total	Free	Available	Thin Provisioning	Auto Tiering	Encryption	Volumes	Current Controller
Pool-1	Online	Good	3.27 TB	3.27 TB	3.27 TB	Disabled	Enabled	Disabled	0	Controller 1

Disk Groups

No.	Status	Health	Total	Free	Tier Level	RAID	Disks Used	RAID 2.0 Spare
1	Online	Good	16.37 TB	16.37 TB	NL-SAS	RAID 5	4	N/A
2	Online	Good	371.00 GB	371.00 GB	SSD	RAID 1	2	N/A

Disks

Enclosure ID	Slot	Status	Health	Capacity	Disk Type	Manufacturer	Model
0	3	Online	Good	372.36 GB	SAS SSD 12.0Gb/s	SEAGATE	ST400FM0053
0	4	Online	Good	372.36 GB	SAS SSD 12.0Gb/s	SEAGATE	ST400FM0053

Create Pool

Figure 11-33 Transfer Thin Provisioning Pool to Auto Tiering Step 3

- Auto Tiering** status is **Enabled**. The thin provisioning pool has been transferred to auto tiering.



INFORMATION:

The total capacity of the pool is the sum of all tiers.



CAUTION:

The action of transferring from the thin provisioning pool to auto tiering is irreversible. Please consider carefully all possible consequences before taking this step.

11.7. SSD Cache vs. Auto Tiering

The SSD cache and auto tiering solutions can work together, and complement each other. A key difference between tiering and cache is that tiering moves data to SSD instead of simply caching it. Tiering can also move data both from slower storage to faster storage and vice versa. But SSD cache is essentially a one-way transaction. When the cache is done with the data it was accelerating it simply nullifies it instead of copying it back to HDD. The important difference between moves and copies is that a cache does not need to have the redundancy that tiering does. Tiering stores the only copy of data for potentially a considerable period of time so it needs to have full data redundancy like RAID or mirroring.

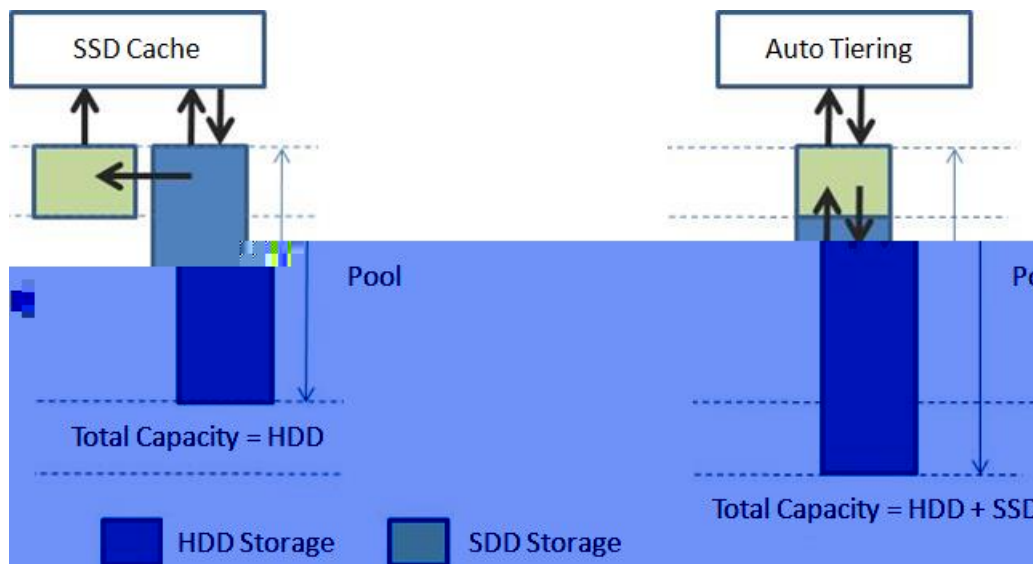

Figure 11-34 SSD Cache vs. Auto Tiering

Total storage capacity in auto tiering is a sum of all individual tier capacities whereas in cache, the cache capacity does not add to the overall slower storage capacity. This is one of the key differences. In addition, SSD cache affects rapidly than auto tiering because auto tiering will be affected by relocation of the data in a period of time. So SSD cache warm-up timeframe is usually minutes/hours whereas tiering warm-up is usually in days.

SSD cache is used for highly frequent data access environment and is effective in a short term such as virtualization or video editing applications. However, auto tiering is used for predictable I/O workloads and is effective in a long term. It's suitable for web, file, or email server applications.

Table 11-7 SSD Cache vs. Auto Tiering

	SSD Cache	Auto Tiering
Total Capacity	HDD	HDD + SSD
When SSD is Damaged	Pool Works Fine	Pool Fails
Performance	Effective in Short Term	Effective in Long Term

12. Data Backup

This chapter describes an overview and operations of data backup options in SANOS. SANOS provides built-in data backup services for protecting data from most unpredictable accidents including:

- Volume snapshot which is described in the [Managing Snapshots](#) section.
- Local volume cloning which is described in the [Manage Local Clones](#) section.
- Remote replication to have data duplicated to the remote sites, the function is described in the [Managing Remote Replications](#) section.

The **DATA BACKUP** function menu provides submenus of **Snapshots** and **Replications**. Clone function is built in the **Volumes** function tab of the **Volumes** function submenu.

12.1. Managing Snapshots

A volume snapshot is based on copy-on-write technology. It's a block-based and differential backup mechanism. Snapshot functionality is designed to be highly efficient, it keeps a point in time record of block-level, incremental data changes of the target LUN volume. Snapshot can help recover a LUN volume to a previous state quickly to meet enterprise SLA (Service Level Agreement) requirements of RPO (Recovery Point Objectives) and RTO (Recovery Time Objective).

Snapshot is the easiest and most effective measure to protect against ransomware attacks, virus attacks, accidental file deletion, accidental file modification, or unstable system hardware caused by a bad I/O cable connection, unstable power supply... etc.

12.1.1. Theory of Operation

Snapshot-on-the-box captures the instant state of data in the target volume in a logical sense. The underlying logic is copy-on-write, moving out the data which would be written to certain location where a write action occurs since the time of data capture. The certain location, named as "Snapshot Volume", is essentially a new volume which can be attached to a LUN provisioned to a host as a disk like other ordinary volumes in the system.

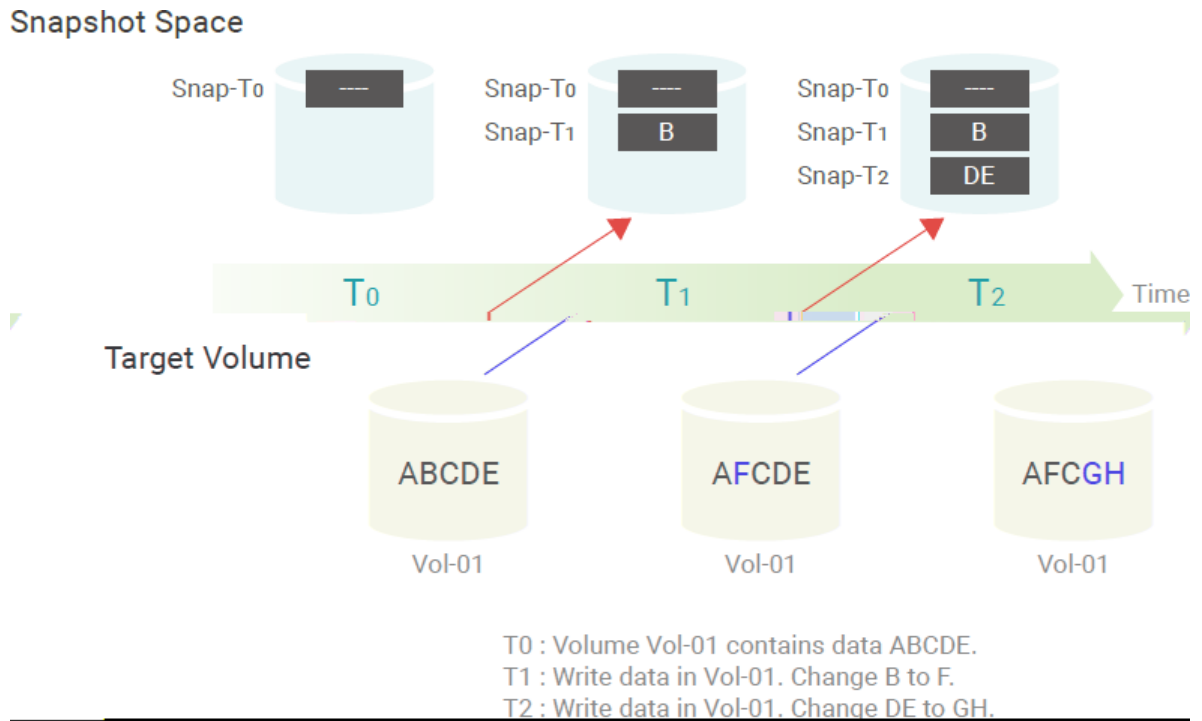

Figure 12-1 Copy-on-Write Technology

Snapshot Rollback

Rollback restores the data back to the state of any time which was previously captured in case for any unfortunate reason it might be. Snapshot volume is allocated within the same pool in which the snapshot is taken, we suggest reserving 20% of the pool capacity or more for snapshot space.

Writable Snapshot

Apart from the rollback function, snapshot allows direct access to the snapshot content with read or read/write permissions. There are two benefits: One is that it will not consume the free capacity of the storage pool. The other one is that it will not affect the content of the target volume. Before attaching a LUN to the snapshot, the snapshot needs to be exposed to be prepared for accessing. An example of these benefits would be, programmers or developers can easily test a previous version of their compiled codes simply by mounting an older snapshot version onto a LUN instead of rolling back the snapshot and overwriting the existing source codes.

Integration with Windows VSS (Volume Shadow Copy Services)

Snapshot is fully compatible with Windows VSS (Volume Shadow Copy Services). VSS is a host memory flush mechanism for creating consistent point in time copies of data known as “shadow copies”. A Windows agent utility is provided to bridge and synchronize the information between the SAN system and Windows operating system. After implementation, you can trigger a snapshot directly from the Windows operating system without any data consistency issues.

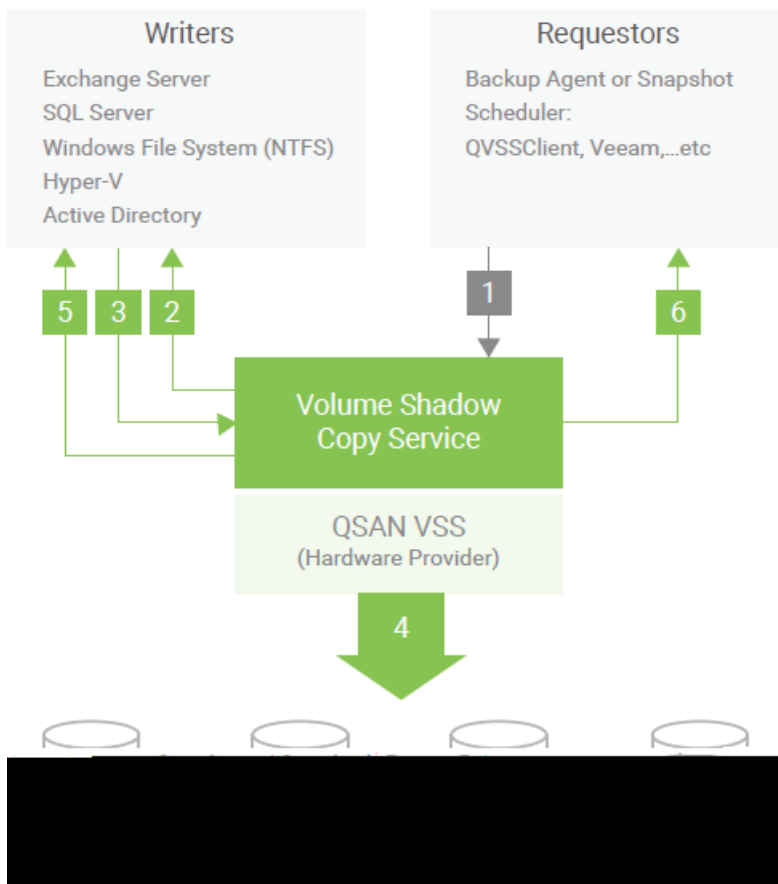

Figure 12-2 Volume Shadow Copy Services Workflow

Select **Snapshots** function submenu to setup snapshot space, take snapshots, list snapshots, setup snapshot schedule, and delete snapshots.

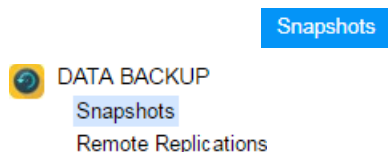

Figure 12-3 Snapshot Function Submenu

The maximum snapshot quantity per volume is 64, and the maximum volume quantity for snapshot is also 64. So a system can have 4,096 snapshots.

Table 12-1 Snapshot Parameters

Item	Value
Maximum snapshot quantity per volume	64
Maximum volume quantity for snapshot	64
Maximum snapshot quantity per system	4,096 (= 64 x 64)

12.1.2. Configure Snapshot

Set Snapshot Space

Before taking a snapshot, SANOS must reserve some storage space for saving variant data. Here’s an example of setting snapshot space.

1. There are two methods to set snapshot space. Select the **Snapshots** function submenu, click the **Set Snapshot Space** button. Or select the **Volumes** function submenu, selects a volume, then click ▼ -> **Set Snapshot Space**.

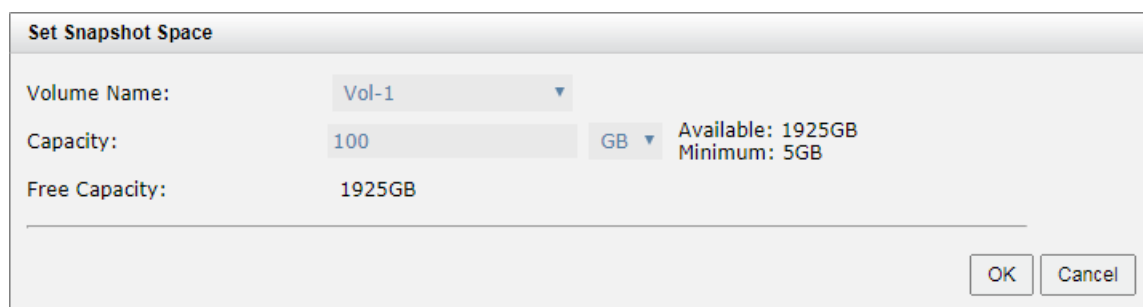

Figure 12-4 Set Snapshot Space

2. Enter a **Capacity** which is reserved for the snapshot space, and then click the **OK** button. The minimum capacity is suggested to set 20% of the volume. Now there are two

capacities in **Snapshot Space** column in the **Volumes** function tab. The first capacity is current used snapshot space, and the second capacity is reserved total snapshot space.

Take a Snapshot

Here's an example of taking a snapshot of the volume.

1. There are two methods to take snapshot. Select the **Snapshots** function submenu, click **Take Snapshot** button. Or select the **Volumes** function submenu, selects a volume, then click ▼ -> **Take Snapshot**.

The screenshot shows a dialog box titled "Take Snapshot". It contains two input fields: "Volume Name" with a dropdown menu showing "Vol-1" and "Snapshot Name" with a text input field containing "Snap-Vol-1". An information icon (i) is located to the right of the "Snapshot Name" field. At the bottom right, there are two buttons: "OK" and "Cancel".

Figure 12-5 Take Snapshot

2. Enter a **Snapshot Name**. The maximum length of the snapshot name is 32 characters. Valid characters are [A~Z | a~z | 0~9 | -_<>].
3. Click the **OK** button. The snapshot is taken.

List Snapshots

Select the **Snapshots** function submenu, the drop-down lists at the top enable you to switch the volumes.

The screenshot shows a table titled "List Snapshots". At the top, there is a dropdown menu labeled "Show snapshots for volume:" with "Vol-1" selected. Below the menu is a table with the following columns: Snapshot Name, Status, Health, Used, Exposure, Permission, LUN, and Time Created. The table contains one row for "Snap-Vol-1".

	Snapshot Name	Status	Health	Used	Exposure	Permission	LUN	Time Created
▼	Snap-Vol-1	N/A	Good	0 MB	No	N/A	None	Wed Jul 12 13:24:46 2017

Figure 12-6 List Snapshots

This table shows the column descriptions.

Table 12-2 Snapshot Column Descriptions

Column Name	Description
Snapshot Name	The snapshot name.
Status	The status of the snapshot: <ul style="list-style-type: none"> • N/A: The snapshot is normal. • Replicated: The snapshot is for clone or replication usage. • Undeletable: The snapshot is undeletable. • Aborted: The snapshot is over space and abort.
Health	The health of the snapshot: <ul style="list-style-type: none"> • Good: The snapshot is good. • Failed: The snapshot has failed.
Used	The amount of the snapshot space that has been used.
Exposure	The snapshot is exposed or not.
Permission	The permission of the snapshot: <ul style="list-style-type: none"> • N/A: Unknown when the snapshot is unexposed. • Read-write: The snapshot can be read / write. • Read-only: The snapshot is read only.
LUN	The LUN status of the snapshot: <ul style="list-style-type: none"> • None: The snapshot is not mapped any LUN. • Mapped: The snapshot is mapped a LUN.
Time Created	The created time of the snapshot.

Select the **Volumes** function submenu, selects a volume, then click ▼ -> **List Snapshots**.

Snapshot Name	Status	Health	Used	Exposure	Permission	LUN	Time Created
Snap-Vol-1	N/A	Good	0 MB	No	N/A	None	Wed Jul 12 13:24:46 2017

Figure 12-7 List Snapshots

Expose Snapshot

Here's an example of exposing a snapshot.

1. Select the **Snapshots** function submenu, click ▼ -> **Expose Snapshot** to set writable snapshot capacity to expose the snapshot.

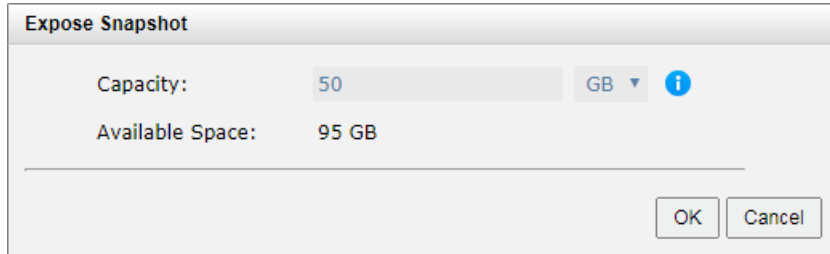

Figure 12-8 Set Writable Snapshot Capacity to Expose Snapshot

2. Enter a **Capacity** which is reserved for the snapshot. If the size is 0, the exposed snapshot will be read only. Otherwise, the exposed snapshot can be read / written, and the size will be the maximum capacity for writing.
3. Click the **OK** button.
4. Click ▼ -> **Map LUN** to map a LUN to the snapshot. Please refer to the chapter 8.6, [Configure LUN Mappings](#) section for detail.
5. Done. The Snapshot can be used as a volume.



TIP:

If the capacity of exposed snapshot is set to 0, the snapshot is read only. If it is not 0, the snapshot can be writable and it becomes writable snapshot.

Unexpose Snapshot

Here's an example of unexposing a snapshot.

1. Select the **Snapshots** function submenu, click ▼ -> **Unexpose Snapshot** to unexposed snapshot
2. Click **OK** button.

Configure LUN Mappings

1. Select the **Snapshots** function submenu, click ▼ -> **Map LUN** to map a LUN to the snapshot. Please refer to the chapter 8.6, [Configure LUN Mappings](#) section for detail.
2. Click ▼ -> **List LUNs** to list all LUNs of the snapshot.

3. Click ▼ -> **Unmap LUNs** to unmap LUNs from the snapshot.

Delete One Snapshot

Select **Snapshots** function submenu, click ▼ -> **Delete** to delete the snapshot. All snapshots after deleted one will be deleted.



CAUTION:

If a snapshot has been deleted, the other snapshots which are earlier than it will also be deleted. The space occupied by these snapshots will be released after deleting.

Delete All Snapshots

To cleanup all the snapshots, please follow these steps.

1. There are two methods to cleanup snapshots. Select the **Snapshots** function submenu, click **Delete Snapshots** button. Or select the **Volumes** function submenu, select a volume. And then click ▼ -> **Delete Snapshots**.
2. Click the **OK** to apply. It will delete all snapshots of the volume and release the snapshot space.

12.1.3. Configure Rollback Snapshot

Rollback Snapshot

The data in snapshot can rollback to the original volume. Please follow the procedures.

1. Select the **Snapshots** function submenu, select a snapshot. And then click ▼ -> **Rollback Snapshot** to rollback the snapshot to the volume.
2. Click the **OK** to apply.



CAUTION:

Before executing rollback, it is better that the disk is unmounted on the host computer for flushing data from cache.

When a snapshot has been rolled-back, the related snapshots which are earlier than it will also be removed. But the rest snapshots will be kept after rollback.

12.1.4. Configure Schedule Snapshots

The snapshots can be taken by schedule such as hourly or daily. Please follow the procedures.

1. There are two methods to set schedule snapshots. Select the **Snapshots** function submenu, click the **Schedule Snapshots** button. Or select the **Volumes** function submenu, selects a volume. And then click ▼ -> **Schedule Snapshots**.

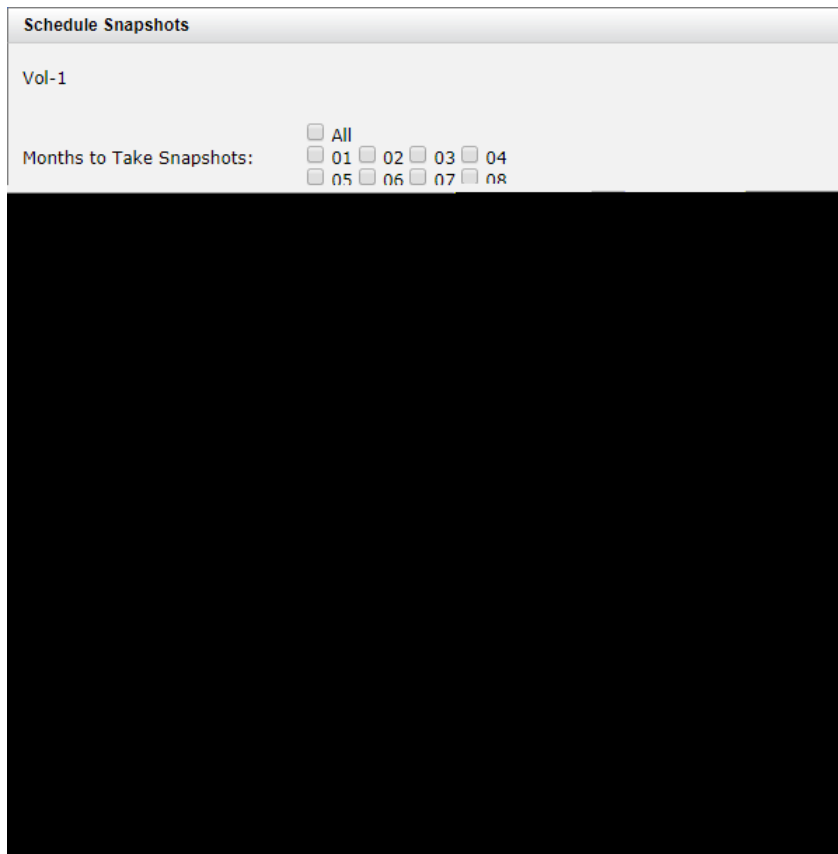

Figure 12-9 Schedule Snapshots

2. Check the schedules you want to set. They can be set by monthly, weekly, daily, or hourly. Check the **Auto Mapping** box to map a LUN automatically when the snapshot is taken. And the LUN is allowed to access by the **Allowed Hosts** column.
3. Click the **OK** to apply.

**INFORMATION:**

Daily snapshot will be taken at 00:00 daily.

Weekly snapshot will be taken every Sunday at 00:00.

Monthly snapshot will be taken every first day of the month at 00:00.

12.1.5. Snapshot Notices

Snapshot function applies copy-on-write technique on volume and provides a quick and efficient backup methodology. When taking a snapshot, it does not copy any data at first time until a request of data modification comes in. The snapshot copies the original data to snapshot space and then overwrites the original data with new changes. With this technique, snapshot only copies the changed data instead of copying whole data. It will save a lot of disk space.

Data Consistent Snapshot

Before using snapshot, users should understand why sometimes the data becomes corrupted after rollback of snapshot. Please refer to the following diagram.

When the data is modified from the host computer, the data will pass through file system and memory of the host (write cache). Then the host will flush the data from memory to physical disks, no matter the disk is local disk (IDE or SATA), DAS (SCSI or SAS), or SAN (fibre or iSCSI). From the viewpoint of the storage device, it cannot control the behavior of the host side. It sometimes happens that when a snapshot is taken, some data is still in memory and did not flush to disk. Then the snapshot may have an incomplete image of the original data. The problem does not belong to the storage device. To avoid this data inconsistency issue between a snapshot and original data, the user has to make the operating system flushes the data from memory of the host (write cache) into disk before taking snapshot.

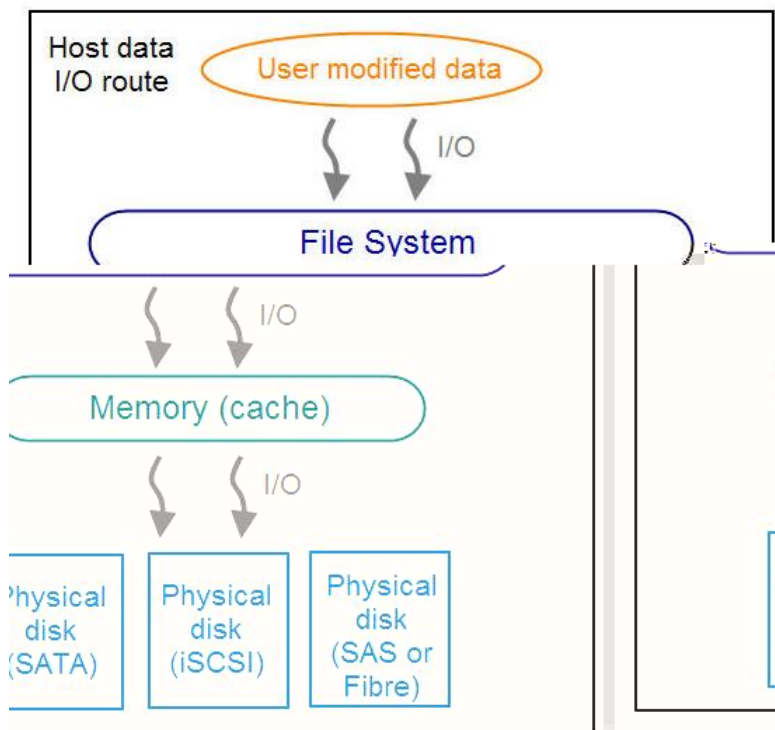

Figure 12-10 Host data I/O Route

On Linux and UNIX platforms, a command named **sync** can be used to make the operating system flush data from write cache to disk. For the Windows platform, Microsoft also provides a tool – **sync**, which does exactly the same thing as the **sync** command in Linux/UNIX. It will tell the OS to flush the data on demand. For more information about **sync** tool, please refer to <http://technet.microsoft.com/en-us/sysinternals/bb897438.aspx>

Besides the **sync** tool, Microsoft developed **VSS** (volume shadow copy service) to prevent this issue. VSS is a mechanism for creating consistent “point-in-time” copies of data known as shadow copies. It is a coordinator between backup software, application (SQL or Exchange...) and storage systems to make sure snapshots can occur without the problem of data-irregularities. For more information about the VSS, please refer to <http://technet.microsoft.com/en-us/library/cc785914.aspx>. QSAN storage systems fully support Microsoft VSS.

**CAUTION:**

Snapshot function can only take the image of data which has been written into the corresponding volume, for the cached data that resides in the server's cache, that doesn't yet be flushed into the storage system, it is unable to protect, which means the taken snapshot might consist of inconsistent data/file/boot image, please make sure to take snapshot at the time point when there is no data I/O incoming to the storage system, to prevent the situation as much as possible. Any functionality that base on snapshot function to perform will have this kind of concern, e.g., local clone and remote replication.

SUGGESTION:

It is recommended to use native remote replication function upon the corresponding Operating System to prevent the situation, e.g., vSphere Replication (VR), so that the cached data can be seamlessly replicated to the target site.

Run Out of Snapshot Space

Before using snapshot, a snapshot space is needed from pool capacity. After a period of working snapshot, what if the snapshot size over the snapshot space of user defined? There are two different situations:

1. If there are two or more snapshots existed, the system will try to remove the oldest snapshots (to release more space for the latest snapshot) until enough space is released.
2. If there is only one snapshot existed, the snapshot will fail. Because the snapshot space is run out.

For example, there are two or more snapshots existed on a volume and the latest snapshot keeps growing. When it comes to the moment that the snapshot space is run out, the system will try to remove the oldest snapshot to release more space for the latest snapshot usage. As the latest snapshot is growing, the system keeps removing the old snapshots. When it comes that the latest snapshot is the only one in system, there is no more snapshot space which can be released for incoming changes, then snapshot will fail.

Maximum Snapshot Quantity per Volume

There are up to 64 snapshots can be created per volume. What if the 65th snapshot has been taken? There are two different situations:

1. If the snapshot is configured as schedule snapshot, the latest one (the 65th snapshot) will replace the oldest one (the first snapshot) and so on.
2. If the snapshot is taken manually, when taking the 65th snapshot will fail and a warning message will be showed on web user interface.

Rollback and Delete Snapshot

When a snapshot has been rolled back, the related snapshots which are later than it will also be removed. But the rest snapshots will be kept after rollback. If a snapshot has been deleted, the other snapshots which are earlier than it will also be deleted. The space occupied by these snapshots will be released after deleting.

12.2. Managing Local Clones

Local clone is used to make a duplicate copy of a volume in the same storage pool as well as in a separate storage pool within the same enclosure. In setting up local clone task, the first clone is a full copy. From now on, the cloning is a differential copy, created using snapshot functionality. Manual and scheduled tasks are available for management flexibility. In the event that the source volume is broken and it fails, IT managers can quickly switch to the cloned volume and resume data services.



Figure 12-11 Local Clone Diagram

12.2.1. Theory of Operation

At the beginning, copy all data from the source volume to target. It is also called full copy. Afterwards, take a snapshot on source volume and then copy delta data to perform the incremental copy.



TIP:

Please be fully aware that the incremental copy needs to use snapshot to compare the data difference. Therefore, having enough snapshot space for the volume is very important.

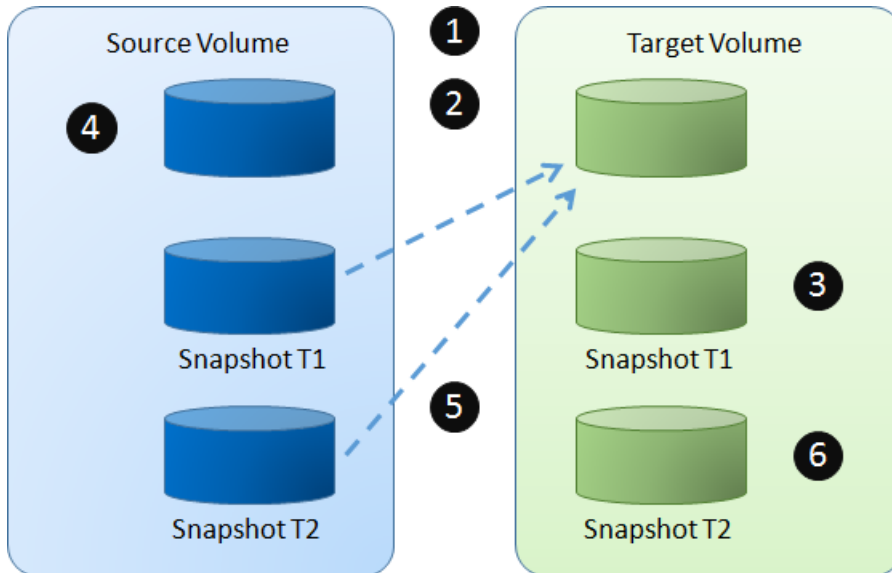

Figure 12-12 Local Clone Steps

In general, local clone operates as follows:

1. Create a local clone task, 2 snapshots are taken on the Source Volume.
2. Data from the Source Snapshot T1 is copied to the Target Volume.
3. The Target Snapshot T1 is refreshed and becomes the common base.
4. Host keeps writing new data to the Source Volume.
5. At next synchronization, the Source Snapshot T2 is refreshed and copies only the changes since the last synchronization.
6. The Target Snapshot T2 is refreshed and becomes the common base.

The local clone operations are under the **Volumes** function tab which provides to setup local clone task, start or stop the tasks, setup local clone schedule, and delete tasks. The maximum clone task quantity per volume is 1, and the maximum clone task quantity per system is 64.

Table 12-3 Local Clone Parameters

Item	Value
Maximum clone task quantity per volume (Maximum clone pairs per source volume)	1
Maximum clone task quantity per system	64

Rollback Local Clone

Rollback local clone operates are in the following:

1. After completing the local clone task, the data can be rolled-back.
2. Exchange the roles of source and target volume, follow the operations on local clone to create a local clone task. Notice that the data in original volume will be destroyed. You have to comprehensive consideration before doing.
3. Or create a new target volume to backup to.

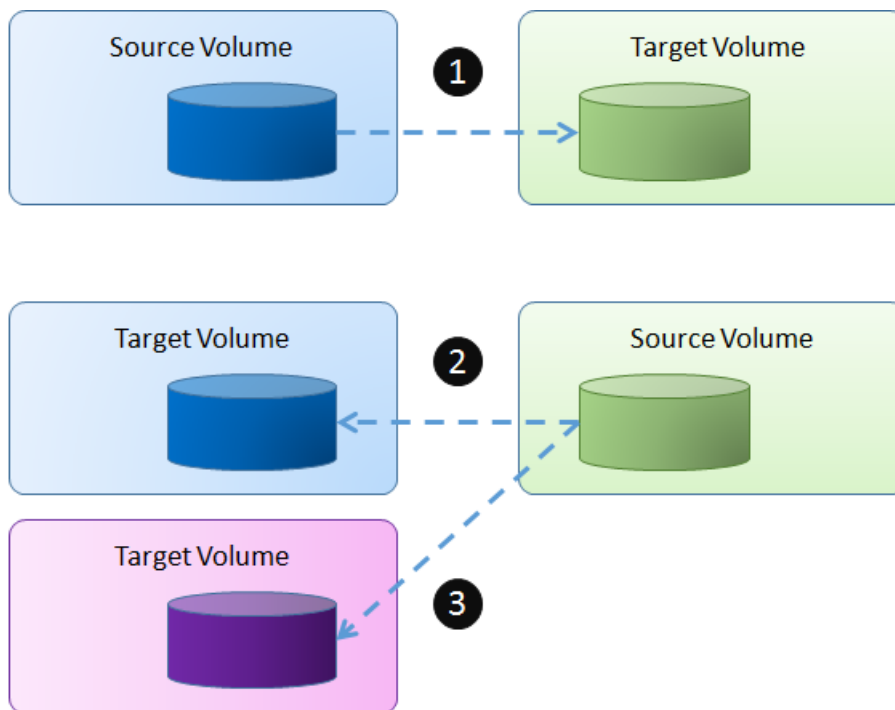

Figure 12-13 Rollback Local Clone

12.2.2. Configure Local Clone

Create a Local Clone Task

Here's an example of creating a local clone from source volume to target one. Assume that we define the name in the example.

- Source Volume Name: Source-Vol-1
- Target Volume: Name: Target-Vol-2

1. Before cloning, it must have a backup target volume. Select the **Volumes** function submenu, click the **Create Volume** button. And then select **Volume Type** to **Backup Volume**. Please refer to the chapter 8.5.1, [Create a Volume](#) section for detail.

Create Volume

General

Volume General Settings

Please enter a volume name and configure the volume general settings.

Volume Name : Target-Vol-2 ⓘ

Pool Name : Pool-1 (Available : 1107 GB)

Capacity : 11 GB

Volume Type : RAID Volume

Select RAID Volume for Backup Volume for backup usage such as the target volume of local clone or remote replication.

RAID Volume

Backup Volume

Next Cancel

Figure 12-14 Create Target Volume

<< first < prev 1 next > last >>

Volume Name	Status	Health	Capacity	Volume Type	SSD Cache	Snapshot Space	Snapshots	Clone	Write	Pool Name		
Target-Vol-2	Disabled	0 MB / 0 MB	0	N/A	WB	Pool-1	▼	Target-Vol-2	Online	Optimal	11.00 GB	Backu

<< first < prev 1 next > last >>

Figure 12-15 List Source and Target Volumes for Local Clone

2. Select the source volume, and then click ▼ -> **Create Local Clone**.
3. Select a target volume, and then click the **OK** button.

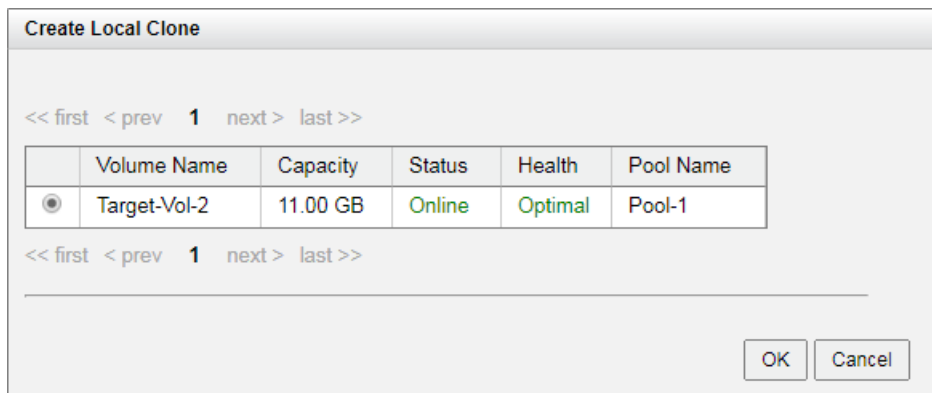

Figure 12-16 Create Local Clone



TIP:

The volume type of the target volume should be set as **Backup Volume**. Please refer to the chapter 8.5.1, [Create a Volume](#) in the Storage Management chapter.

4. At this time, if the source volume has no snapshot space, it will be allocated snapshot space for clone usage automatically. The capacity will depend on the parameter of **Cloning Options**.
5. Done, now ready to start cloning volumes.

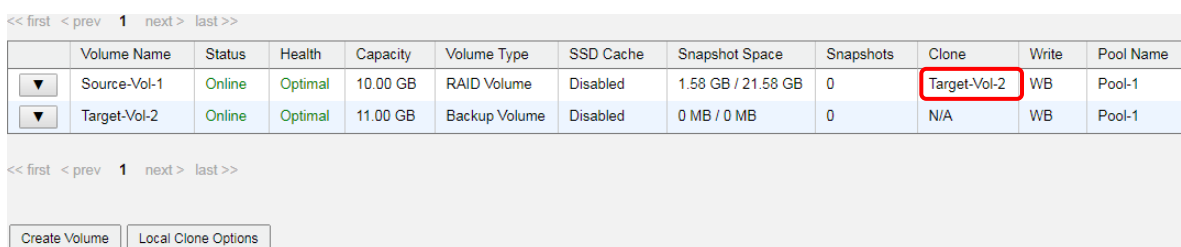

Figure 12-17 List Source and Target Volumes

Start Local Clone Task

To start cloning, please follow the procedures.

1. Select the source volume, and then click ▼ -> **Start Local Clone**.
2. Click the **OK** button. The source volume will take a snapshot, and then start cloning.

Stop Local Clone Task

To stop cloning, please follow the procedures.

1. Select the source volume, and then click ▼ -> **Stop Local Clone**.
2. Click the **OK** button to stop cloning.

Delete Local Clone Task

To clear the clone task, please follow the procedures.

1. Select the source volume, and then click ▼ -> **Delete Local Clone**.
2. Click the **OK** button to clear clone task.

12.2.3. Configure Schedule Local Clone Tasks

The clone task can be set by schedule such as hourly or daily. Please follow the procedures.

1. Select the source volume, and then click ▼ -> **Schedule Local Clone**.

Schedule Local Clone

Set Local Clone Schedule: Source-Vol-1

Months in the Year: All
 01 02 03 04
 05 06 07 08
 09 10 11 12

Weeks in the Month: All
 1 2 3 4
 5

Days of the Week: All
 Sun Mon Tue Wed
 Thu Fri Sat

Hours in the Day: All
 00 01 02 03
 04 05 06 07
 08 09 10 11
 12 13 14 15
 16 17 18 19
 20 21 22 23

Minutes in the Hour: All
 00 15 30 45

OK Cancel

Figure 12-18 Schedule Local Clone

2. Check the schedules which you want. They can be set by monthly, weekly, daily, or hourly. Click the **OK** button to apply.



INFORMATION:

Daily snapshots will be taken at 00:00 daily.

Weekly snapshot will be taken every Sunday at 00:00.

Monthly snapshot will be taken every first day of the month at 00:00.

12.2.4. Local Cloning Options

Select the **Volumes** function submenu, click the **Local Clone Options** button. Three options are described in the following.

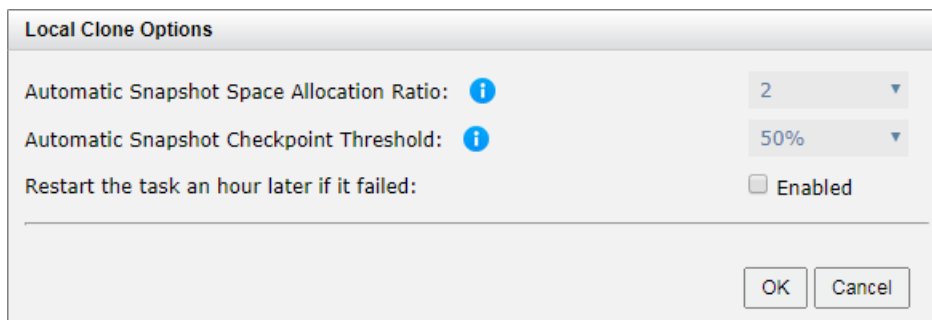

Figure 12-19 Local Cloning Options

- **Automatic Snapshot Space Allocation Ratio:** This setting is the ratio of the source volume and snapshot space. If the ratio is set to 2, when there is no snapshot space assigned for the volume, the system will automatically reserve a free pool space to set as the snapshot space with twice capacity of the volume. The options are 0.5 ~ 3.
- **Automatic Snapshot Checkpoint Threshold:** The setting will be effective after enabling schedule clone. The threshold will monitor the usage amount of the snapshot space. When the used snapshot space achieves the threshold, system will take a snapshot and start clone process automatically. The purpose of threshold could prevent the incremental copy failure immediately when running out of the snapshot space. For example, the default threshold is 50%. The system will check the snapshot space every hour. When the snapshot space is used over 50%, the system will start clone task automatically. And then continue monitoring the snapshot space. When the rest

snapshot space has been used 50%, in other words, the total snapshot space has been used 75%, the system will start clone task again.

- **Restart the task an hour later if failed:** The setting will be effective after enabling a scheduled clone. When running out of snapshot space, the volume clone process will be stopped because there is no more available snapshot space. If this option is checked, the system will clear the snapshots of clone in order to release snapshot space automatically, and the clone task will be restarted after an hour. This task will start a full copy.



CAUTION:

The default snapshot space allocated by the system is two times the capacity of source volume. That is the best value of our suggestion. If user sets snapshot space manually and lower than the default value, understand that if the snapshot space is not enough, the clone task will fail.

12.2.5. Local Clone Notices

While the clone is processing manually, the incremental data of the volume is over the snapshot space. The clone will complete the task, but the clone snapshot will fail. At the next time, when trying to start clone, it will get a warning message “There is not enough of snapshot space for the operation”. The user needs to clean up the snapshot space in order to use the clone feature. Each time the clone snapshot failed, it means that the system loses the reference value of incremental data. So it will need to make a full copy the next time a clone task starts.

12.3. Managing Remote Replications

Remote replication is a block-level, asynchronous, differential remote volume backup function through LAN or WAN. It has many powerful capabilities such as unlimited bandwidth, traffic shaping, and multiple connections per replication task.



Figure 12-20 Remote Replication Diagram

Remote replication uses the iSCSI function to set up a replication connection. It can use the full bandwidth of the assigned network port to allow the best backup speed. However, in order to balance replication traffic and non-replication traffic, the traffic shaping function can help to reserve necessary bandwidth for non-replication I/O.

If the replication task requires more bandwidth, Remote replication allows multiple connections per task by intelligently balancing the backup task across multiple connections to enhance the bandwidth.

Both manual and scheduled replication tasks are supported for flexible management. To handle huge data remote replication, Remote replication allows transforming local cloning task into a remote replication task. You can perform the local clone first for the full copy. Then use disk roaming function to physically transport the disk drives that contain the cloned volume to the remote site. Lastly, use the function of transforming from the local clone task to the remote replication one.



Figure 12-21 Local Clone Transfers to Remote Replication

12.3.1. Remote Replication Topologies

Remote replication supports multiple topologies to suit various disaster recovery configurations. They are one-directional, bi-directional, one-to-many, many-to-one, and

many-to-many. Both the source volume and destination volume in a replication connection are exclusive to the pair. Either one can NOT be served as the source or destination volume of a different replication connection. Each SAN storage system can support up to 32 replication tasks concurrently. Below are the supported topologies.

One-Directional



Figure 12-22 One-Directional Remote Replication

A Source Volume (S) in Site A is replicating to a Target Volume (T) in Site B. This is the most basic remote replication topology.

Bi-Directional



Figure 12-23 Bi-Directional Remote Replication

Each system in a two system topology acts as a replication target for the other's production data. A Source Volume (S1) in Site A is replicating to a Target Volume (T1) in Site B. And a Source Volume (S2) in Site B is replicating to a Target Volume (T2) in Site A.

One-to-Many

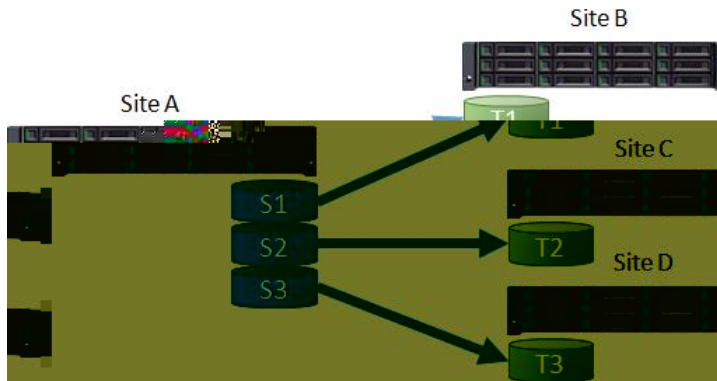

Figure 12-24 One-to-Many Remote Replication

A single source system replicates different storage resources to multiple target systems. A Source Volume (S1) in Site A is replicating to a Target Volume (T1) in Site B. At the same time, a Source Volume (S2) in Site A is replicating to a Target Volume (T2) in Site C. So does S3 in Site A to T3 in Site D.

Many-to-One

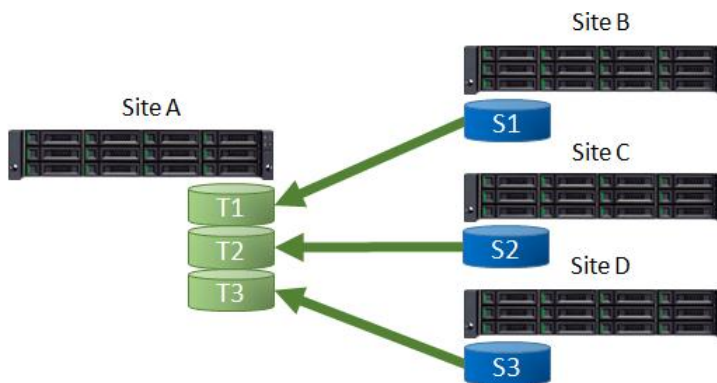

Figure 12-25 Many-to One Remote Replication

Multiple source systems replicate to a single target system. A Source Volume (S1) in Site B is replicating to a Target Volume (T1) in Site A. At the same time, a Source Volume (S2) in Site C is replicating to a Target Volume (T2) in Site A. So does S3 in Site D to T3 in Site A.

Many-to-Many

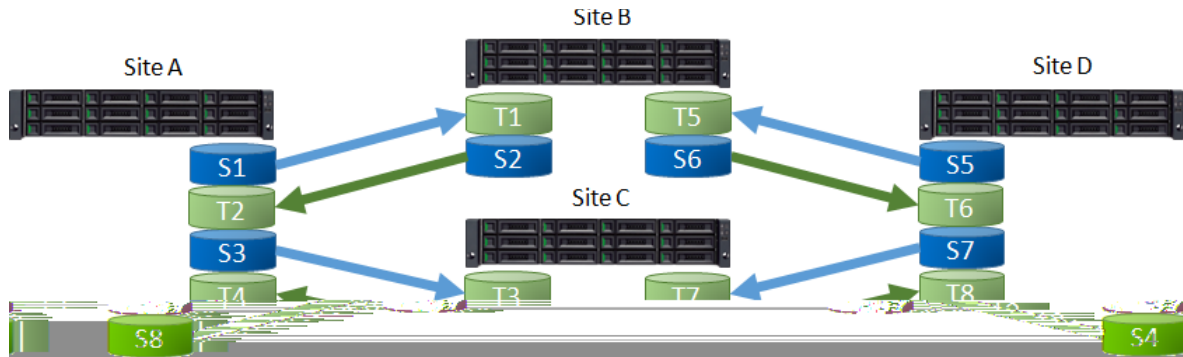

Figure 12-26 Many-to Many Remote Replication

Combination with bi-Directional, one-to-many, and many-to-one, remote replication also supports Many-to-Many topology. Multiple source systems replicate to multiple target systems. A Source Volume (S1) in Site A is replicating to a Target Volume (T1) in Site B. At the same time, a Source Volume (S2) in Site B is replicating to a Target Volume (T2) in Site A. And does S3 to T3, S4 to T4, ..., S8 to T8.



TIP:

Note that all supported topologies have a 1-to-1 configuration for each individual replication session in the topology.

The maximum replication task quantity per system is 32. It means that 32 systems are the maximum quantity of any many-to-one or one-to-many replication configuration.

12.3.2. Theory of Operation

At the beginning, replication will copy all data from the source volume to the target. It is also called a full copy. Afterwards, use snapshot technology to perform the incremental copy.



TIP:

Please be fully aware that the incremental copy needs to use snapshot to compare the data difference. Therefore, sufficient snapshot space for the volume is very important.

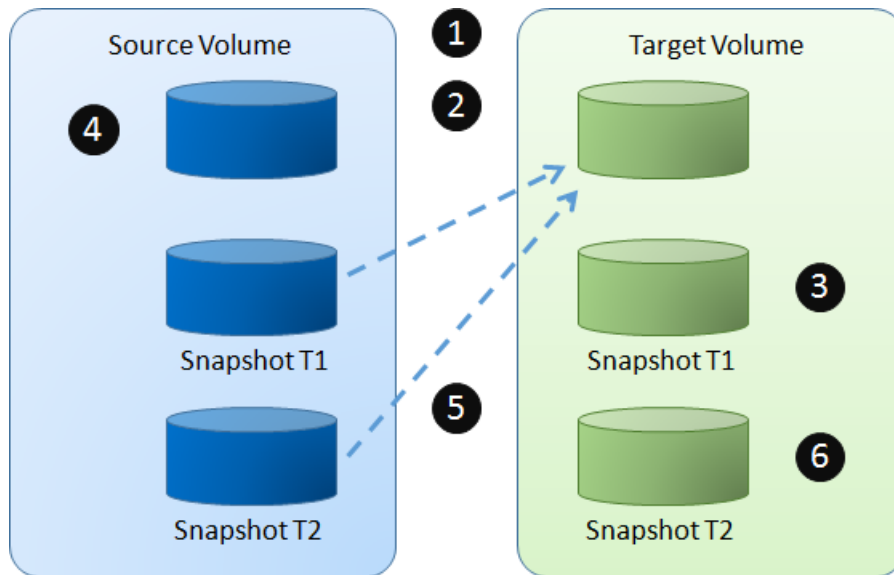

Figure 12-27 Remote Replication Steps

In general, remote replication operates in the following way.

1. Create a remote replication task, as the time going, two snapshots are taken on the Source Volume.
2. Data from the Source Snapshot T1 is copied to the Target Volume.
3. The Target Snapshot T1 is refreshed and becomes the common base.
4. Host keeps writing new data to the Source Volume.
5. At next synchronization, the Source Snapshot T2 is refreshed and copies only the changes since last synchronization.
6. The Target Snapshot T2 is refreshed and becomes the common base.

Select the **Remote Replications** function submenu to setup remote replication task, start, or stop tasks, setup remote replication schedule, delete tasks, and also setup traffic shaping.

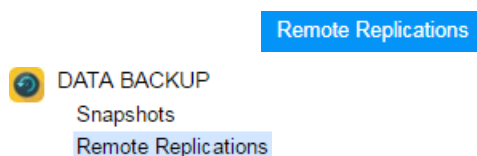

Figure 12-28 Snapshot Function Submenu

The maximum replication task quantity per volume is 1, and the maximum replication task quantity per system is 32, and the maximum traffic shaping quantity per system is 8.

Table 12-4 Remote Replication Parameters

Item	Value
Maximum remote replication task quantity per volume (Maximum remote replication pairs per source volume)	1
Maximum remote replication task quantity per system	32
Maximum traffic shaping quantity per system	8
Maximum iSCSI multi-path quantity in a remote replication task	2
Maximum iSCSI multiple connection quantity per remote replication task path	4

12.3.3. Configure Remote Replication

Create a Remote Replication Task

Here's an example of creating a remote replication task from source volume to target one. Assume that we define the name and the IP addresses in the example.



Figure 12-29 Example of Creating a Remote Replication Task

Site A Source Unit Configuration:

- Controller 1, Onboard LAN 1 IP Address: 10.10.1.1
- Controller 1, Onboard LAN 2 IP Address: 10.10.1.2
- Controller 2, Onboard LAN 1 IP Address: 10.10.1.3
- Controller 2, Onboard LAN 2 IP Address: 10.10.1.4
- Source Volume Name: Source-Vol-1

Site B Target Unit Configuration:

- Controller 1, Onboard LAN 1 IP Address: 10.10.1.101
- Controller 1, Onboard LAN 2 IP Address: 10.10.1.102
- Controller 2, Onboard LAN 1 IP Address: 10.10.1.103
- Controller 2, Onboard LAN 2 IP Address: 10.10.1.104
- Target Volume: Name: Target-Vol-2

3. Map a LUN of the target volume. Please refer to the chapter 8.6, [Configure LUN Mappings](#) section in the Storage Management chapter.

Operate web UI of Site A source unit:

4. Select the **Remote Replications** function submenu, click the **Create** button.

	Volume Name	Capacity	Status	LUN	Snapshots	Pool Name
<input checked="" type="radio"/>	Source-Vol-1	10.00 GB	Online	None	0	Pool-1

Figure 12-32 Create a Remote Replication Task Step 1

5. Select a source volume, and then click the **Next** button.

Remote Replication - Set Source Port and Target IP Address

Source Port:

Target IP Address:

Figure 12-33 Create a Remote Replication Task Step 2

6. Select the **Source Port** and input the **Target IP Address**, and then click the **Next** button.



TIP:

Leave the setting of the **Source Port** to **Auto** if you don't want to assign a fixed one. The system will try to connect to the target IP address automatically.

Remote Replication - Set Authentication Method and Select a Target Name

Select an Authentication Method

No Authentication Method

CHAP

CHAP Username:

CHAP Password:

Select a Target Name

	No.	Target Name
<input checked="" type="radio"/>	1	iqn.2004-08.0

Next Cancel Back

Figure 12-34 Create a Remote Replication Task Step 3

7. Select an **Authentication Method** and input the **CHAP Username** and **CHAP Password** if needed. Select a **Target Name**, and then click the **Next** button.



TIP:

This CHAP account is the iSCSI authentication of the Site B target unit. For more information about CHAP, please refer to the chapter 7.3.4, [Configure iSCSI CHAP Accounts](#) section in the Host Configuration chapter.

Select **No Authentication Method** if there is no CHAP enabling in the Site B target unit.

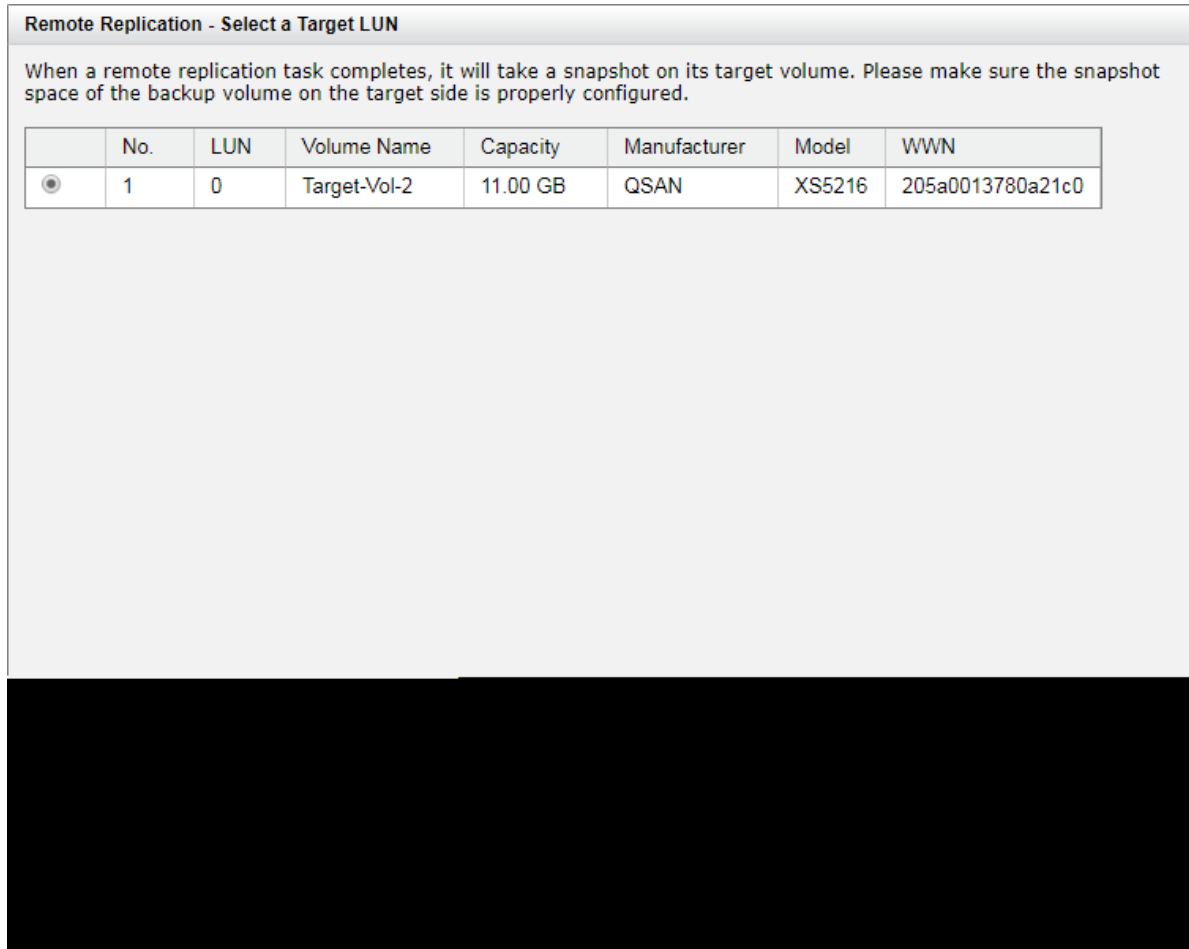

Figure 12-35 Create a Remote Replication Task Step 4

8. Select a Target LUN in Site B target unit. Finally, click the **Finish** button.

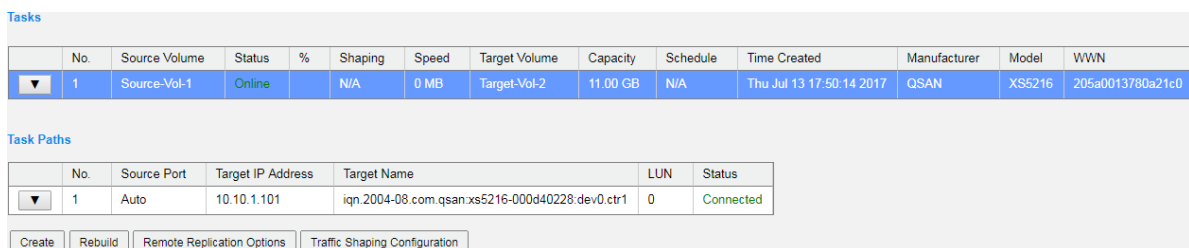

Figure 12-36 Remote Replication Task is Created

9. The replication task is created. At this time, if the source volume has no snapshot space, it will be allocated snapshot space for replication usage automatically. The size will depend on the parameter of replication options.

Start Remote Replication Task

To start the remote replication task, please follow the procedures.

Launch the SANOS web UI of Site A source unit:

1. Select the **Remote Replications** function submenu, select the task, and then click ▼ -> **Start**.
2. Click the **OK** button. The source volume will take a snapshot, and then start remote replication.

Stop Remote Replication Task

To stop remote replication task, please follow the procedures.

Launch the SANOS web UI of Site A source unit:

1. Select the **Remote Replications** function submenu, select the task, and then click ▼ -> **Stop**.
2. Click the **OK** button to stop remote replication.

Delete Remote Replication Task

To delete the remote replication task, please follow the procedures.

Launch the SANOS web UI of Site A source unit:

1. Select the **Remote Replications** function submenu, select the task, and then click ▼ -> **Delete**.
2. Click the **OK** button to delete the remote replication task.

12.3.4. Configure Traffic Shaping

The traffic shaping function can help to reserve necessary bandwidth for non-replication I/O operations. There are eight shaping groups which can be set. In each shaping group, peak and off-peak time slot are provided for different bandwidth. Here's an example of setting shaping group.

Configure Traffic Shaping

To configure traffic shaping groups, please follow the procedures.

Launch the SANOS web UI of Site A source unit:

1. Select the **Remote Replications** function submenu, click the **Traffic Shaping Configuration** button.

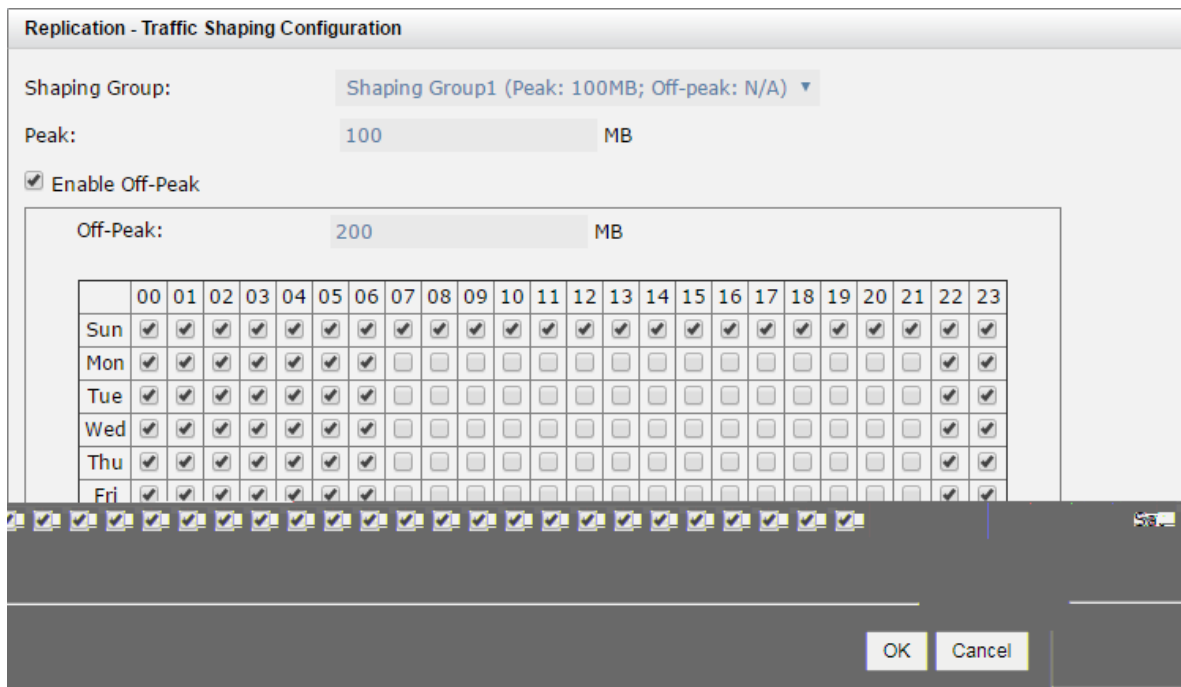

Figure 12-37 Shaping Setting Configuration

2. Select a **Shaping Group** to setup.
3. Input the bandwidth (MB) at the **Peak** time.
4. If needed, check the **Enable Off-Peak** box, and then input the bandwidth (MB) at **Off-Peak** time. And define the off-peak hour.
5. Click the **OK** button.

Set Traffic Shaping on Remote Replication Task

To set a shaping group on the remote replication task, please follow the procedures.

Operate web UI of Site A source unit:

1. Select the **Remote Replications** function submenu, select the task, and then click ▼ -> **Set Traffic Shaping**.

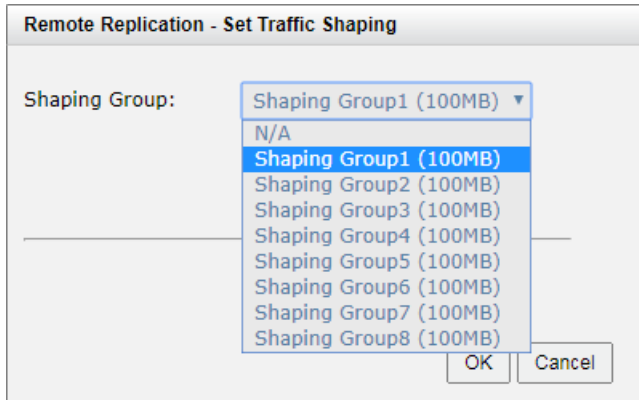

Figure 12-38 Set Traffic Shaping

2. Select a Shaping Group from the drop down list. And then click the **OK** button.
3. The shaping group is applied to the remote replication task.

12.3.5. Configure Schedule Remote Replication Tasks

The replication task can be set by schedule such as hourly or daily. Please follow the procedures.

Operate web UI of Site A source unit:

1. Select the **Remote Replications** function submenu, select the task, and then click ▼ -> **Schedule**.
2. Check the schedules which you want. They can be set by monthly, weekly, daily, or hourly. Click the **OK** button to apply.



INFORMATION:

Daily snapshot will be taken at 00:00 daily.

Weekly snapshot will be taken every Sunday at 00:00.

Monthly snapshot will be taken every first day of the month at 00:00.

Remote Replication - Set Remote Replication Schedule

Set Remote Replication Schedule: Source-Vol-1

Months in the Year: All
 01 02 03 04
 05 06 07 08
 09 10 11 12

Weeks in the Month: All
 1 2 3 4
 5

Days of the Week: All
 Sun Mon Tue Wed
 Thu Fri Sat

Hours in the Day: All
 00 01 02 03
 04 05 06 07
 08 09 10 11
 12 13 14 15
 16 17 18 19

15 30 45

Minutes in the Hour: All
 00

Figure 12-39 Schedule Remote Replication

12.3.6. Replication Options

Select the **Remote Replications** function submenu, click the **Replications Options** button. Three options are described in the following.

Remote Replication Options

Automatic Snapshot Space Allocation Ratio: i

Automatic Snapshot Checkpoint Threshold: i

Restart the task an hour later if it failed: Enabled

Figure 12-40 Replication Options

- **Automatic Snapshot Space Allocation Ratio:** This setting is the ratio of the source volume and snapshot space. If the ratio is set to 2, when there is no snapshot space assigned for the volume, the system will automatically reserve a free pool space to set as the snapshot space with twice capacity of the volume. The options are 0.5 ~ 3.
- **Automatic Snapshot Checkpoint Threshold:** The setting will be effective after enabling schedule replication. The threshold will monitor the usage amount of the snapshot space. When the used snapshot space achieves the threshold, system will take a snapshot and start replication process automatically. The purpose of threshold could prevent the incremental copy failure immediately when running out of the snapshot space. For example, the default threshold is 50%. The system will check the snapshot space every hour. When the snapshot space is used over 50%, the system will start replication task automatically. And then continue monitoring the snapshot space. When the rest snapshot space has been used 50%, in other words, the total snapshot space has been used 75%, the system will start replication task again.
- **Restart the task an hour later if failed:** The setting will be effective after enabling schedule replication. When running out of snapshot space, the volume replication process will be stopped because there is no more available snapshot space. If this option is checked, the system will clear the snapshots of replication in order to release snapshot space automatically, and the replication task will be restarted after an hour. This task will start a full copy.



CAUTION:

The default snapshot space allocated by the system is two times the capacity of source volume. That is the best value of our suggestion. If user sets snapshot space by manually and lower than the default value, user should take the risk if the snapshot space is not enough and the replication task will fail.

12.3.7. Configure MPIO in Remote Replication Task

In remote replication scenario, MPIO (Multi-Path I/O) are support for redundancy. Normally, the remote replication task is running on the master controller (usually is controller 1) of source unit. The data is replicated from the master controller of source unit to the controller of target unit which target IP Address sets in creating remote replication task (usually is also controller 1). The second path from source unit can be added to the controller 2 of

target unit. The maximum MPIO in remote replication task is 2 paths. The following is the remote replication MPIO diagram.

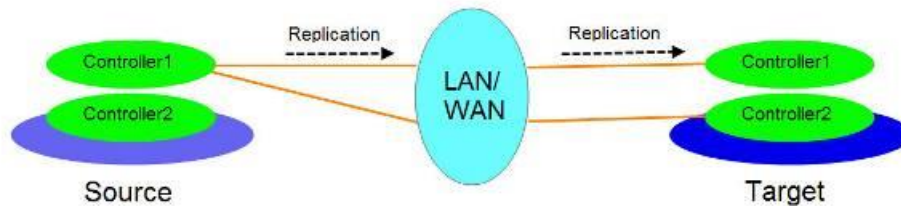

Figure 12-41 Remote Replication MPIO Diagram

How Redundancy Works with Remote Replication

If controller 1 fails on the source unit, the replication connection will be taken over by controller 2 and the replication task will continue running.

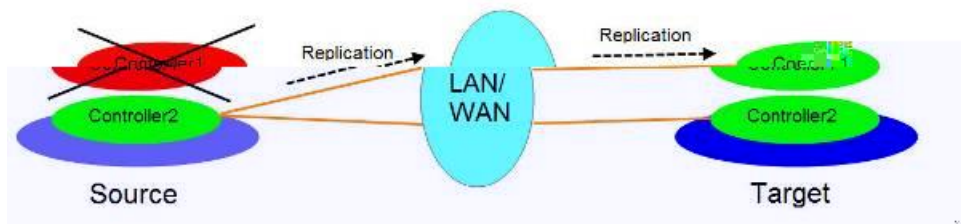

Figure 12-42 Remote Replication Source Controller Fail Diagram

In another scenario, when controller1 fails on the target unit, the replication connection will be failed over to the second path from the controller 1 of the source unit to controller 2 of target unit.

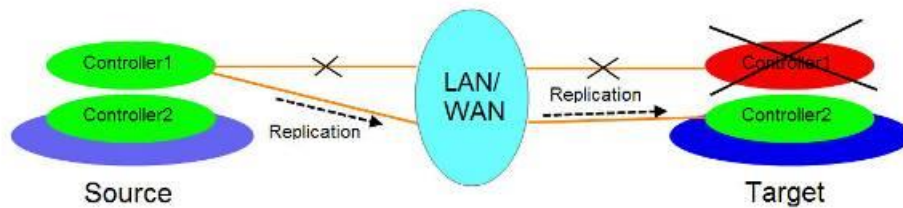

Figure 12-43 Remote Replication Target Controller Fail Diagram

Add Multipath in Remote Replication Task

Here's an example of adding the second path in the remote replication. Assume that we define the IP addresses in the example.

Site A Source Unit Configuration:

- Controller 1, Onboard LAN 1 IP Address: 10.10.1.1
- Controller 1, Onboard LAN 2 IP Address: 10.10.1.2
- Controller 2, Onboard LAN 1 IP Address: 10.10.1.3
- Controller 2, Onboard LAN 2 IP Address: 10.10.1.4
- Source Volume Name: Source-Vol-1

Site B Target Unit Configuration:

- Controller 1, Onboard LAN 1 IP Address: 10.10.1.101
- Controller 1, Onboard LAN 2 IP Address: 10.10.1.102
- Controller 2, Onboard LAN 1 IP Address: 10.10.1.103
- Controller 2, Onboard LAN 2 IP Address: 10.10.1.104
- Target Volume: Name: Target-Vol-2

Operate web UI of Site A source unit:

1. Select the **Remote Replications** function submenu, select the task, and then click ▼ -> **Add Multipath**.

Figure 12-44 Add Multipath in Remote Replication Step 1

2. Select the **Source Port**

Remote Replication - Set Authentication Method and Select a Target Name

Select an Authentication Method

No Authentication Method

CHAP

CHAP Username: i

CHAP Password: i

Select a Target Name

	No.	Target Name
<input checked="" type="radio"/>	1	iqn.2004-08.com.qsan:xs5216-000d40228:dev0.ctr2

Figure 12-45 Add Multipath in Remote Replication Step 2

3. Select an **Authentication Method** and input the **CHAP Username** and **CHAP Password** if needed. Select a **Target Name**, and then click the **Next** button.



TIP:

This CHAP account is the iSCSI authentication of the Site B target unit. For more information about CHAP, please refer to the chapter 7.3.4, [Configure iSCSI CHAP Accounts](#) section in the Host Configuration chapter.

Select **No Authentication Method** if there is no CHAP enabled on the Site B target unit.

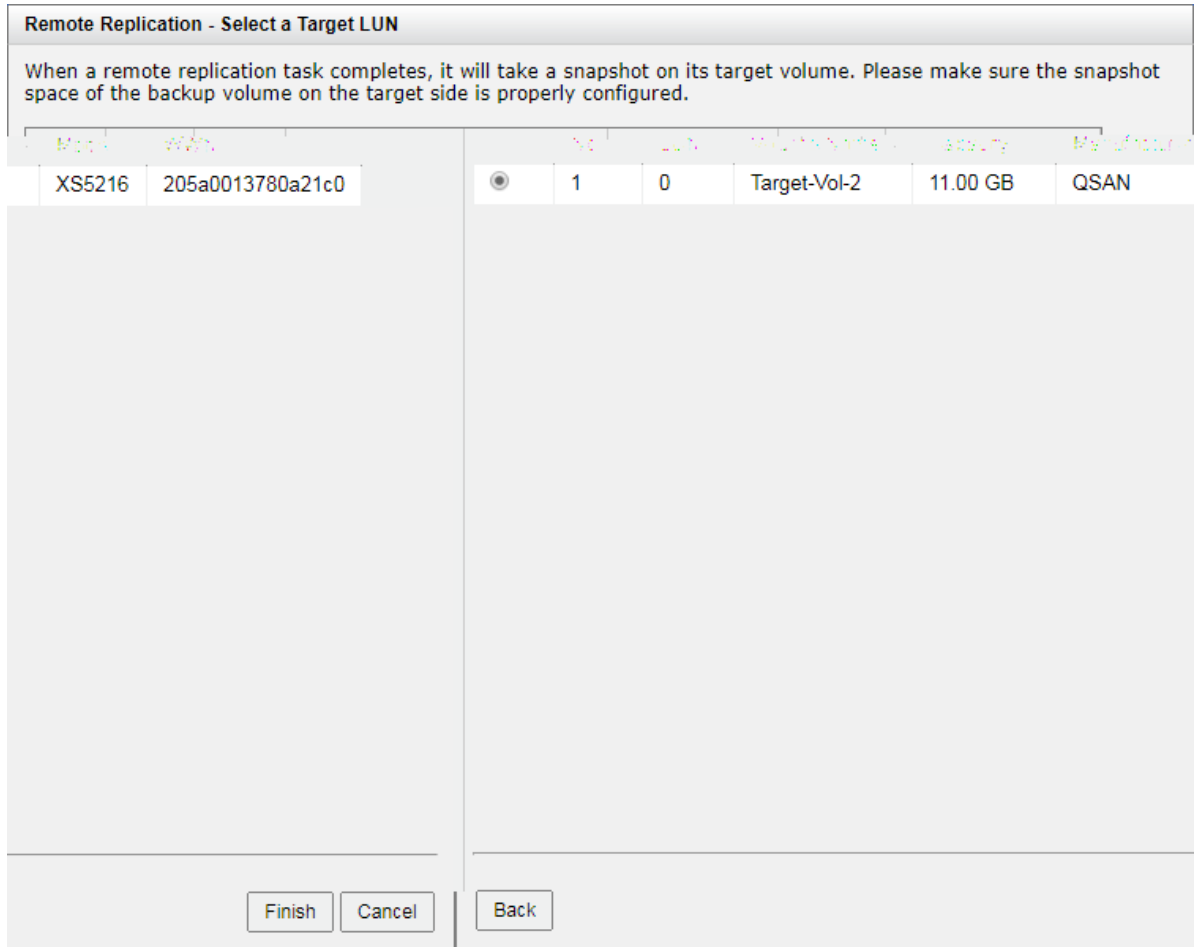

Figure 12-46 Add Multipath in Remote Replication Step 3

4. Select a Target LUN in Site B target unit. Finally, click **Finish** button.

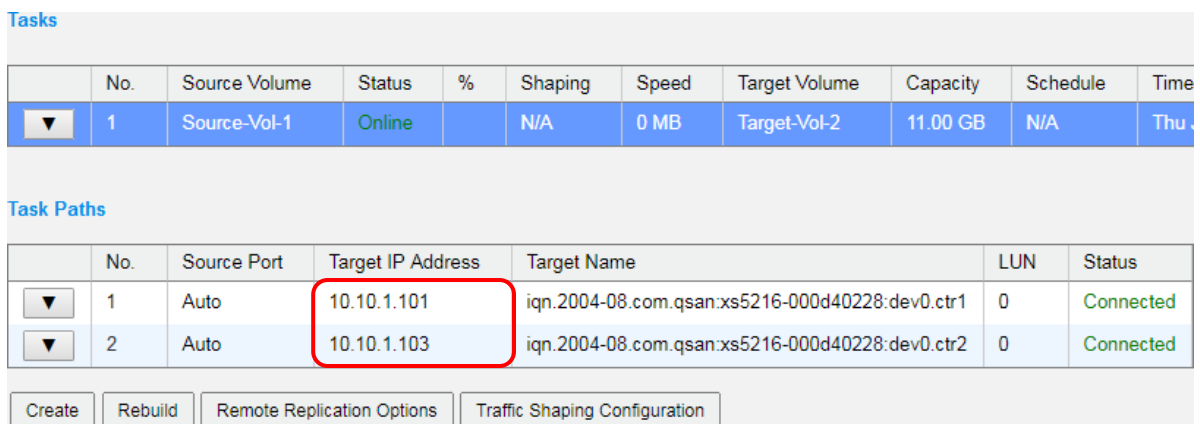

Figure 12-47 List Multipath in Remote Replication Task

5. The second path in remote replication task is added.

Delete Multipath in Remote Replication Task

To delete multi path of the replication task, please follow the procedures.

Operate web UI of Site A source unit:

1. Select the **Remote Replications** function submenu, select the task path, and then click **▼ -> Delete Path**.
2. Click the **OK** button to delete the path.

12.3.8. Configure MC/S in Remote Replication Task Path

MC/S (Multiple Connections per Session) is another feature in remote replication. If there are more than one iSCSI ports available on source unit, and they can connect to the other iSCSI ports of the target unit, MC/S can be added for increasing the replicating speed. The maximum MC/S per task path is 4 connections.

Add Connections in Remote Replication Task Path

Here's an example of adding the second connection in the remote replication task. Assume that we define the IP addresses in the example.

Site A Source Unit Configuration:

- Controller 1, Onboard LAN 1 IP Address: 10.10.1.1
- Controller 1, Onboard LAN 2 IP Address: 10.10.1.2
- Controller 2, Onboard LAN 1 IP Address: 10.10.1.3
- Controller 2, Onboard LAN 2 IP Address: 10.10.1.4
- Source Volume Name: Source-Vol-1

Site B Target Unit Configuration:

- Controller 1, Onboard LAN 1 IP Address: 10.10.1.101
- Controller 1, Onboard LAN 2 IP Address: 10.10.1.102
- Controller 2, Onboard LAN 1 IP Address: 10.10.1.103
- Controller 2, Onboard LAN 2 IP Address: 10.10.1.104
- Target Volume: Name: Target-Vol-2

Operate web UI of Site A source unit:

1. Select the **Remote Replications** function submenu, select the task path, and then click **▼ -> Add Connection**.

Figure 12-48 Add Path Connection

2. Select the **Source Port** and input the **Target IP Address**, and then click the **Next** button.



TIP:

Leave the setting of **Source Port** to **Auto** if you don't want to assign. The system will try to connect to the target IP address automatically.

Tasks

	No.	Source Volume	Status	%	Shaping	Speed	Target Volume	Capacity	Schedule	Time
▼	1	Source-Vol-1	Online		N/A	0 MB	Target-Vol-2	11.00 GB	N/A	Thu

Task Paths

	No.	Source Port	Target IP Address	Target Name	LUN	Status
▼	1	Auto	10.10.1.101	iqn.2004-08.com.qsan:xs5216-000d40228:dev0.ctr1	0	Connected
▼		Auto	10.10.1.102	iqn.2004-08.com.qsan:xs5216-000d40228:dev0.ctr1	0	Connected

Create Rebuild Remote Replication Options Traffic Shaping Configuration

Figure 12-49 List Multiple Connections in Remote Replication Task Path

3. The second connection in remote replication task path is added. If necessary, click ▼ -> **Add Connection** to add another.

Delete Connections in Remote Replication Task Path

To delete multi connections per session of the replication task path, please follow the procedures.

1. Operate Site A source unit. Select the **Remote Replications** function submenu, select the task path, and then click ▼ -> **Delete Connection**.

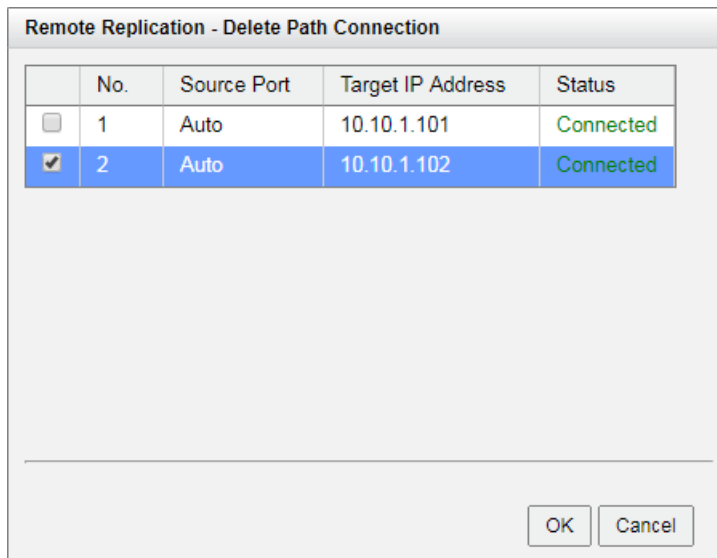

Figure 12-50 Delete Path Connection

2. Select the connection(s) which want to be deleted, and then click the **OK** button.
3. The multiple connection(s) are deleted.



TIP:

When deleting multiple connections, note that at least one connection must remain.

12.3.9. Local Clone Transfers to Remote Replication

It is always being a problem that to do full copy over LAN or WAN when the replication task is executed at the first time. It may take days or weeks to replicate data from source to target within limited network bandwidth. We provide two methods to help users shorten the time of executing a full copy.

1. One is to skip full copy on a new, clean volume. The term “clean” means that the volume has never been written data since created. For a new created volume which has not been accessed, the system will recognize it and skip full copy automatically when the remote replication task is created on this volume at the first time.

**TIP:**

Any I/O access to the new created volume will make it as “not clean”, even though executing “Erase” function when a volume is created. The full copy will take place in such a case.

2. The other way is to use local volume clone function, which is a local data copy function between volumes to execute full copy at the first time. Then carry all the physical disk drives of the target volume and move to the target unit. Finally, turn the local clone task into remote replication task with differential copy afterward.

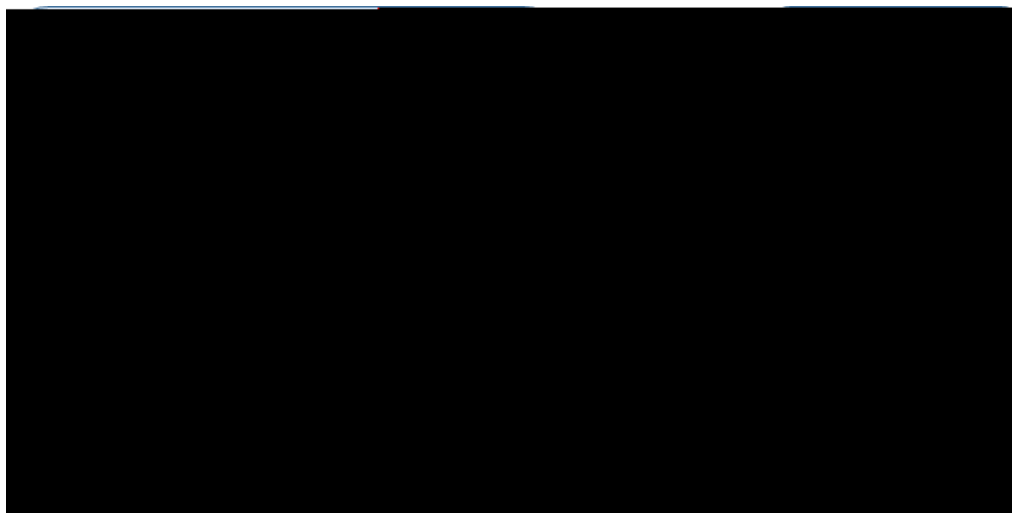

Figure 12-51 Local Clone Transfers to Remote Replication Diagram

To do that volume disk local clone transfers to remote replication, please follow the procedures.

Launch SANOS web UI of Site A source unit:

1. Select the **Volumes** function submenu, select a source volume, and click ▼ -> **Create Local Clone** to create a local clone task. For more information about local clone, please refer to the chapter 12.2.2, [Configure Local Clone](#) section.
2. Click ▼ -> **Start Local Clone** to execute full copy the data from source volume to target

- Map a LUN of the target volume. Please refer to the chapter 8.6, [Configure LUN Mappings](#) section in the Storage Management chapter.

Launch SANOS web UI of Site A source unit:

- Select the **Remote Replications** function submenu, click the **Rebuild** button to rebuild the remote replication task which is changed from a clone task formerly.

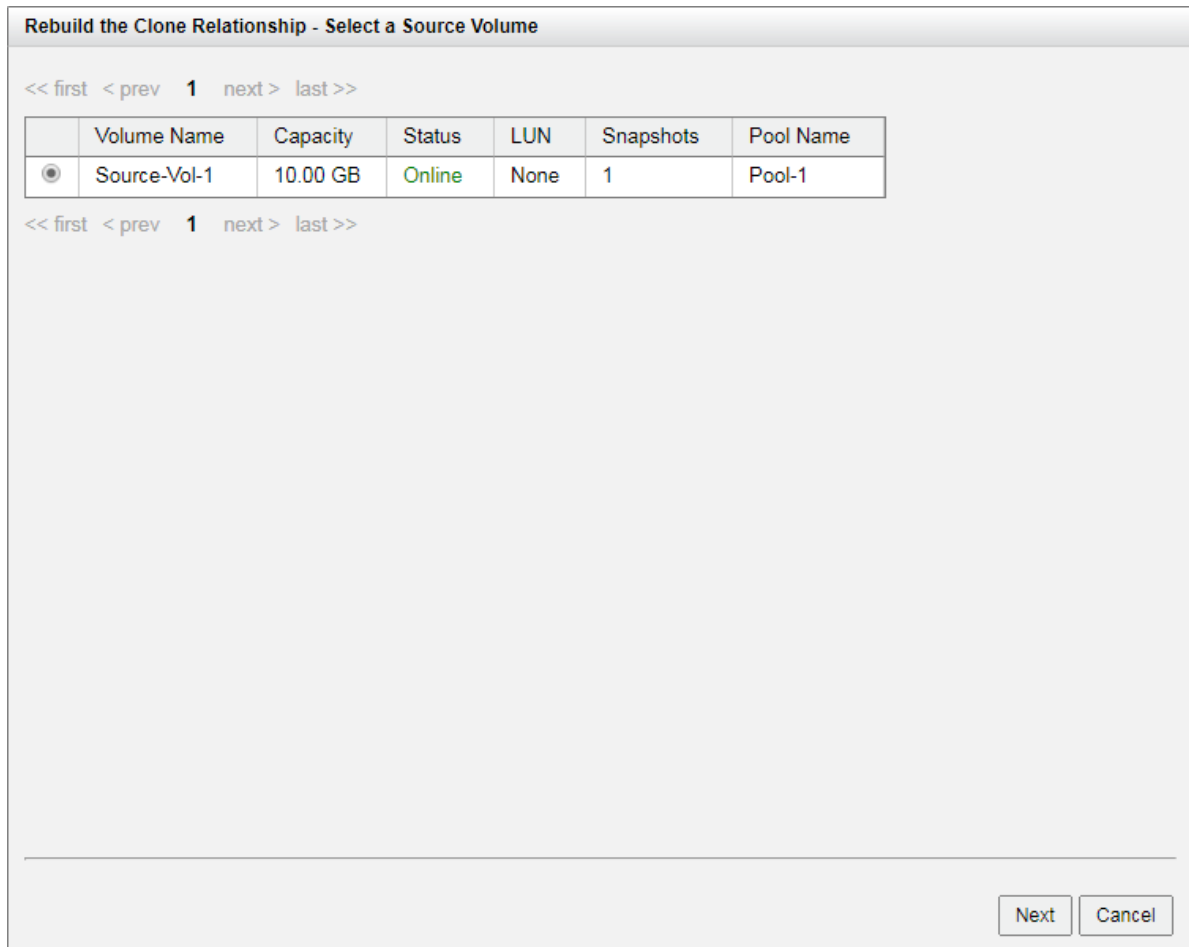

Figure 12-53 Rebuild Clone Relationship Step 1

- Select a source volume, and then click the **Next** button.

Remote Replication - Set Source Port and Target IP Address

Source Port: Auto

Target IP Address: 10.10.1.101

Back Next Cancel

Figure 12-54 Rebuild Clone Relationship Step 2

12. Select the **Source Port** and input the **Target IP Address**, and then click the **Next** button.



TIP:

Leave the setting of **Source Port** to **Auto** if you don't want to assign a fixed one. The system will try to connect to the target IP address automatically.

Figure 12-55 Rebuild Clone Relationship Step 3

13. Select an **Authentication Method** and input the **CHAP Username** and **CHAP Password** if needed. Select a **Target**

Remote Replication - Select a Target LUN

When a remote replication task completes, it will take a snapshot on its target volume. Please make sure the snapshot space of the backup volume on the target side is properly configured.

	No.	LUN	Volume Name	Capacity	Manufacturer	Model	WWN
<input checked="" type="radio"/>	1	0	Target-Vol-2	11.00 GB	QSAN	XS5216	205a0013780a21c0

Figure 12-56 Rebuild Clone Relationship Step 4

14. Select a Target LUN in Site B target unit. Finally, click the **Finish** button.

Tasks

	No.	Source Volume	Status	%	Shaping	Speed	Target Volume	Capacity	Schedule	Time Created	Manufacturer	Model	WWN
▼	1	Source-Vol-1	Online		N/A	0 MB	Target-Vol-2	11.00 GB	N/A	Thu Jul 13 17:50:14 2017	QSAN	XS5216	205a0013780a21c0

Task Paths

	No.	Source Port	Target IP Address	Target Name	LUN	Status
▼	1	Auto	10.10.1.101	iqn.2004-08.com.qsan.xs5216-000d40228:dev0.ctr1	0	Connected

Create Rebuild Remote Replication Options Traffic Shaping Configuration

Figure 12-57 Remote Replication Task is Created

15. The replication task from local clone is created.

13. Monitoring

The **MONITORING** function menu provides submenus of **Log Center**, **Enclosures**, and **Performance**.

13.1. Log Center

Select the **Event Logs** function tab in the **Log Center** function submenu to show event messages. Select or unselect the checkbox of **Information**, **Warning**, or **Error** levels to show or hide those particular events.

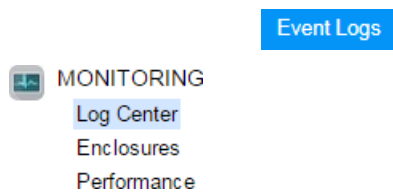

Figure 13-1 Log Center Function Submenu

Information Warning Error

<< first < prev 1 2 3 4 5 6 7 8 9 10 next > last >>

Type	Time	Content
Information	Tue, 04 Oct 2016 15:43:02	[CTR1] Disk 10 has been freed from RAID group 'Pool-2'.
Warning	Tue, 04 Oct 2016 15:43:02	[CTR1] RAID group 'Pool-2' is in degraded mode.
Information	Tue, 04 Oct 2016 15:26:03	[CTR1] Virtual disk 'Vol-3' completed initialization.
Information	Tue, 04 Oct 2016 15:26:03	[CTR1] The snapshot space of virtual disk 'Vol-3' is cleared.
Information	Tue, 04 Oct 2016 15:25:51	[CTR1] Virtual disk 'Vol-3' has started initialization.
Information	Tue, 04 Oct 2016 15:25:51	[CTR1] Set the snapshot space of virtual disk 'Vol-3' to 50000 MB.

Figure 13-2 Event Logs

The event logs are displayed in reverse order which means the latest event log is on the first / top page. They are actually saved in the first four disk drives of the head unit, each disk drive has one copy of event log. For one system, there are four copies of event logs to make sure users can check event log any time when there are failed disks. If there are no disk drives in the first four slots, the event logs will keep in memory temporary, and will disappear after system reboots.

The event logs record all system events. Each event has time frame that identifies the type of event that occurred, and has one of the following severities:

- **Error:** A failure occurred that may affect data integrity or system stability. Correct the problem as soon as possible.
- **Warning:** A problem occurred that may affect system stability, but not data integrity. Evaluate the problem and correct it if necessary.
- **Information:** An operation recorded that may help to debug.

13.1.1. Operations on Event Logs

The options are available on this tab:

Mute Buzzer

Click the **Mute Buzzer** button to stop alarm if the system alerts.

Download Event Logs

Click the **Download** button to save the event log as a file. It will pop up a filter dialog as the following.

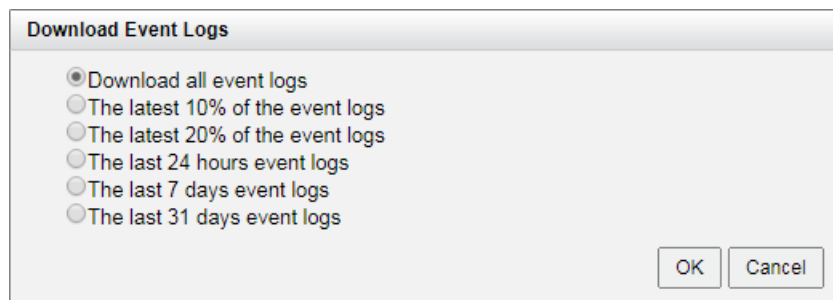

Figure 13-3 Download Event Logs

Select the options and then click the **OK** button to download event logs.

Clear Event Logs

Click the **Clear** button to clear all event logs.

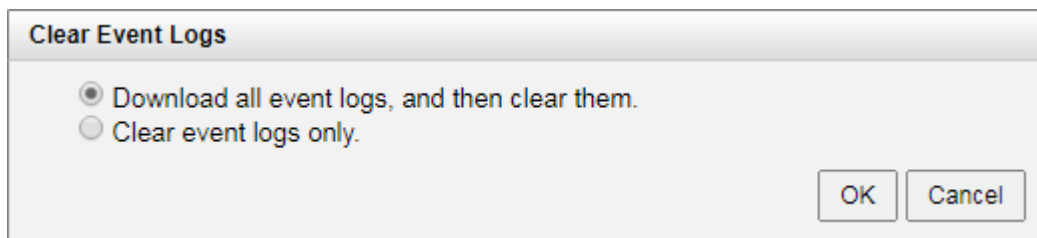

Figure 13-4 Clear Event Logs

Select the options and then click the **OK** button to clear event logs.



TIP:

Please plug-in any of the first four hard drives, then event logs can be saved and displayed in next system boot up. Otherwise, the event logs cannot be saved.

13.2. Monitoring Enclosures

The **Enclosures** function submenu provides **Hardware Monitoring** and **SES** tabs to show and monitor enclosure information.

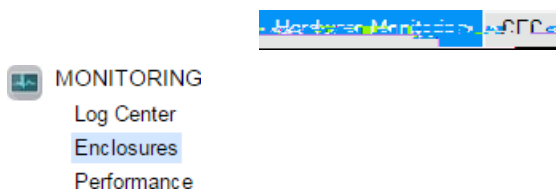

Figure 13-5 Enclosure Function Submenu

13.2.1. Hardware Monitoring

Select the **Hardware Monitoring** function tab in the **Enclosures** function submenu shows the information of current voltages, temperatures, status of power supply's, and fan modules.

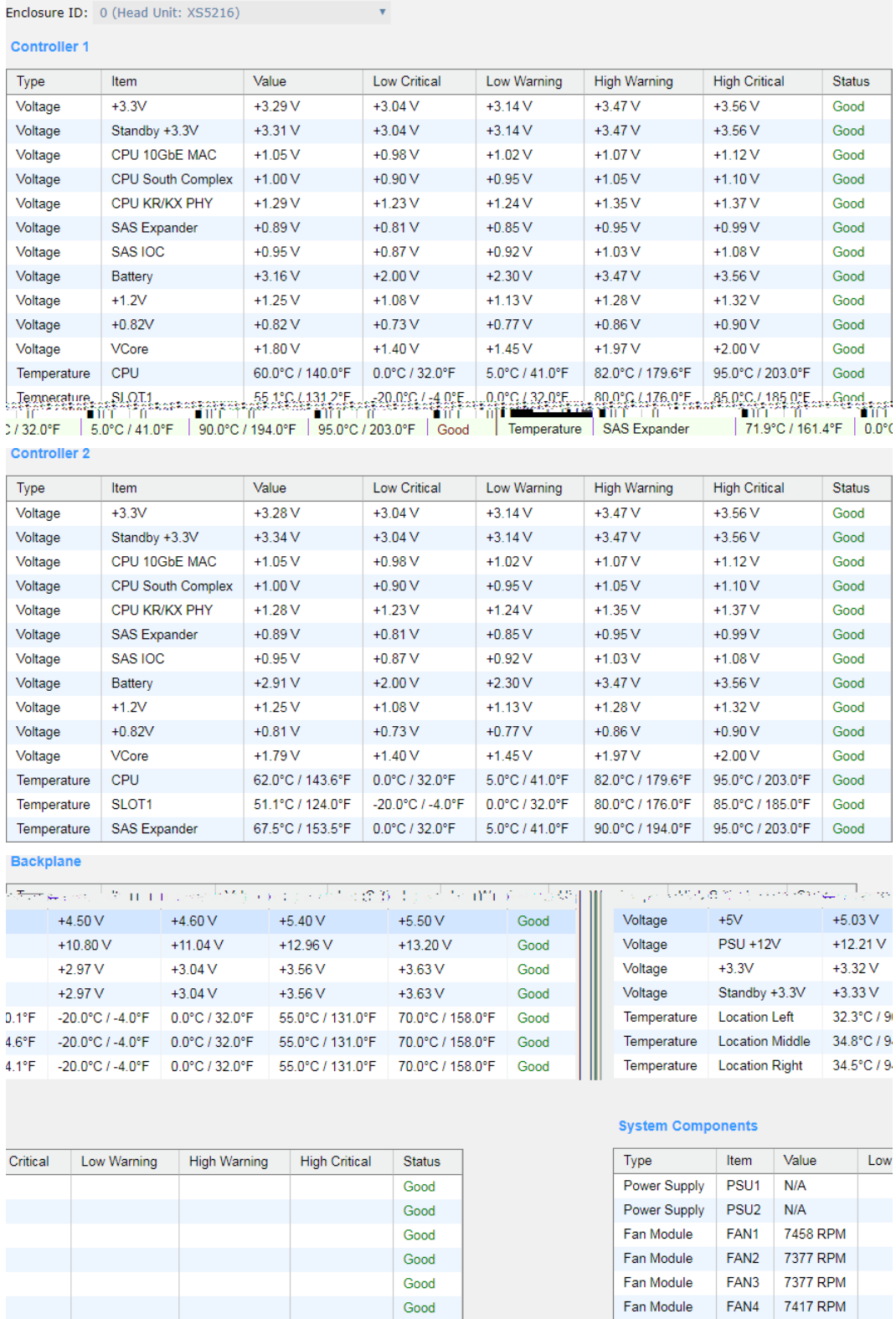

Figure 13-6 Hardware Monitoring

Monitoring Notifications

The status of the voltage and temperature are **Good** if their values are between **Low Warning** and **High Warning**. If the value is lower than **Low Warning** or higher than **High Warning**, the system will send a warning event log. If it is lower than **Low Critical** or higher than **High Critical**, an error event log will be sent.



TIP:

For better protection and avoiding a single short period of abnormal voltage or temperature, its recommend to enable **Auto Shutdown** setting which could trigger an automatic shutdown. This is done using several sensors placed on key systems that the system checks every 30 seconds for present voltages or temperatures. The following items are trigger conditions.

- The value of voltage or temperature is lower than **Low Critical** or higher than **High Critical**.
- When one of these sensors reports above the threshold for three contiguous minutes, the system will be shutdown automatically.

For more information about auto shutdown, please refer to the chapter 6.3.1, [Boot Management Settings](#) section in the System Settings chapter.

Fan Module Mechanism

Fan speed will adjust automatically according to system thermal and the status of power and fan. For more information, please refer to the chapter 2.6, Fan Module and the chapter 6.3, Removing / Installing the Fan Module in the [XCubeSAN Hardware Manual](#).

13.2.2. Configuring SES

SES (SCSI Enclosure Services) is an enclosure management standard. The host can communicate with the enclosure using a LUN and a specialized set of SCSI commands to monitor hardware characteristics. Select **SES** function tab in **Enclosure** function submenu to enable or disable the management of SES. Enable SES will map an iSCSI LUN or a FC LUN.

Enable SES

Here's an example of enabling SES.

1. Select **SES** function tab in **Enclosure** function submenu, click the **Enable SES** button.



Figure 13-7 Enable SES

2. Select the **Protocol** as iSCSI.
3. Enter the **Allowed Hosts** with semicolons (;) or fill-in wildcard (*) for access by all hosts.
4. Select a **Target** from the drop-down list.
5. Click the **OK** button to enable SES.

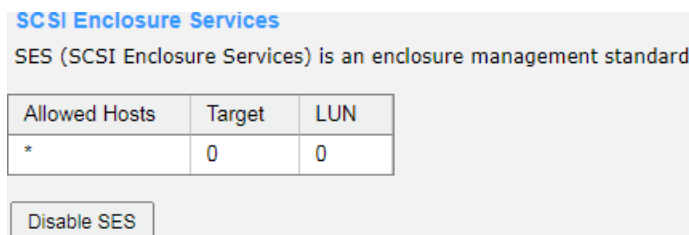

Allowed Hosts	Target	LUN
*	0	0

Figure 13-8 SES Status

Disable SES

Click the **Disable** button to disable SES.

SES Client Tool

The SES client software is available at the following web site:

SANtools: <http://www.santools.com/>

13.3. Performance Monitoring

The **Performance** function submenu provides **Disk**, **iSCSI**, and **Fibre Channel** tabs to monitor performance.



Figure 13-9 Performance Function Submenu

13.3.1. Disk Performance Monitoring

Select the **Disks** function tab in the **Performance** function submenu to display the throughput and latency of the disk drives. Check the slots which you want to monitor.



CAUTION:

Enabling performance monitoring will reduce I/O performance. Please use with caution.

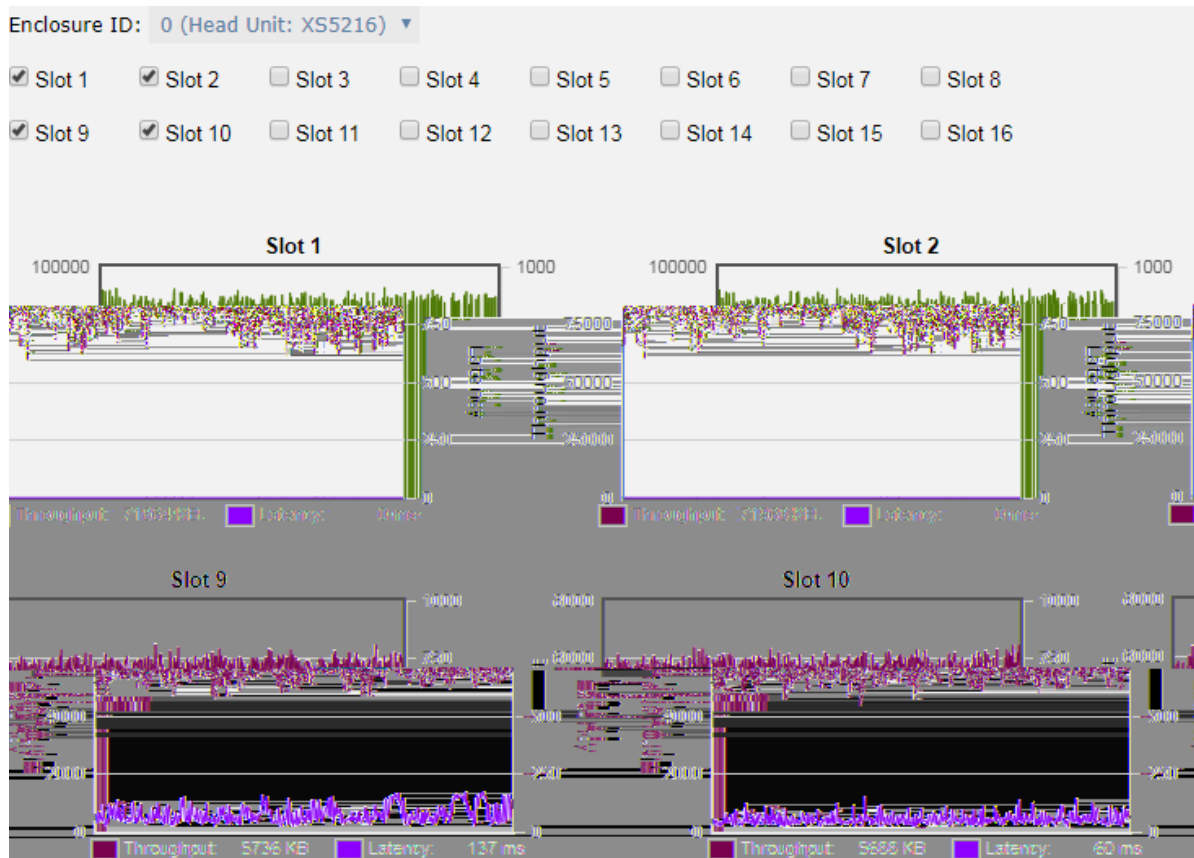

Figure 13-10 Disk Performance Monitoring

13.3.2. Volume Performance Monitoring

Select the **Volume** function tab in the **Performance** function submenu to display throughput, IOPS, and latency of volumes. Each time you can monitor 10 volumes. Note that enabling performance monitoring may impact I/O performance. Please click the **Select Volumes** button to select the volumes for performance monitoring.

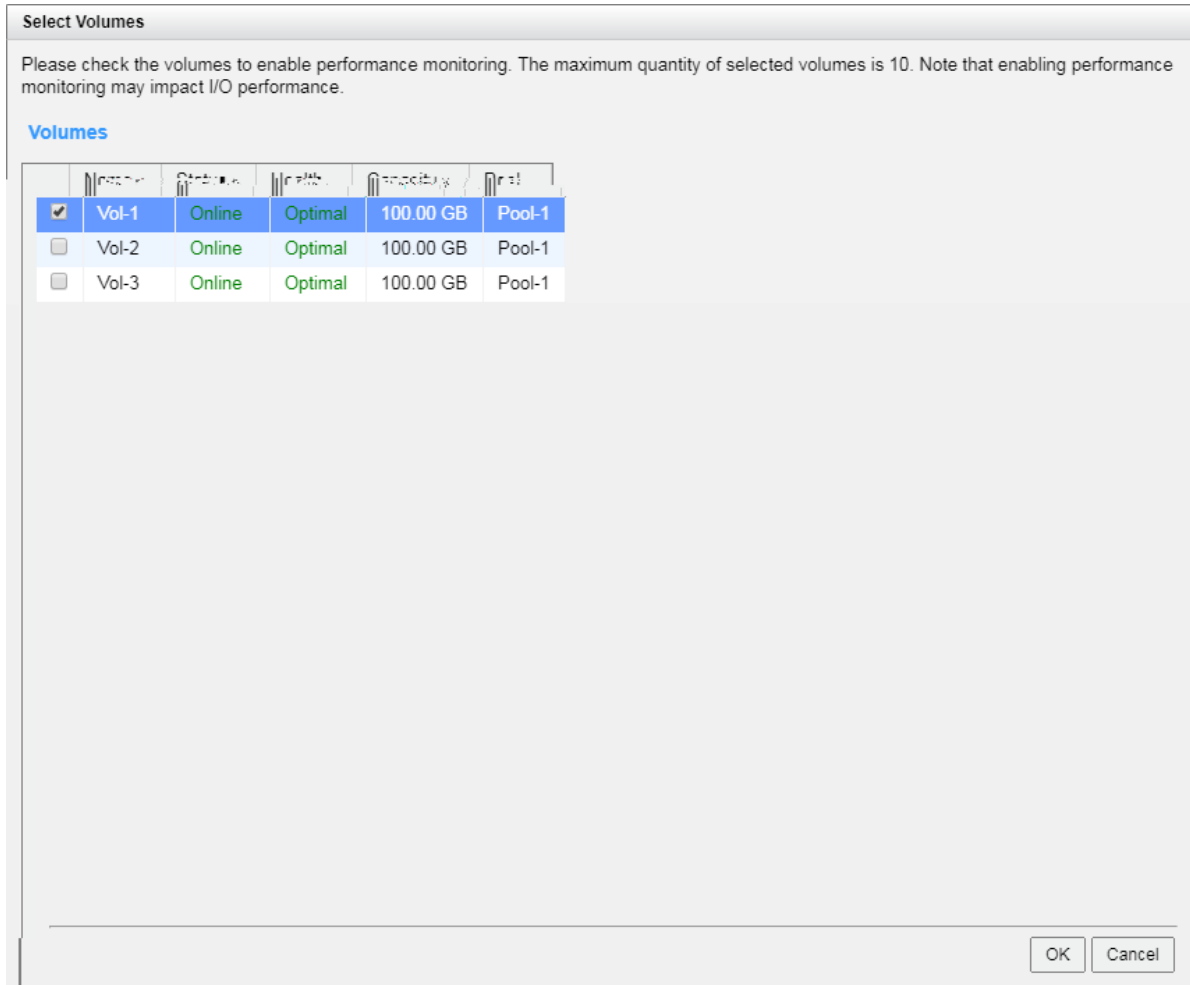

Figure 13-11 Select Volumes to Monitor

Please check the volumes to enable performance monitoring.

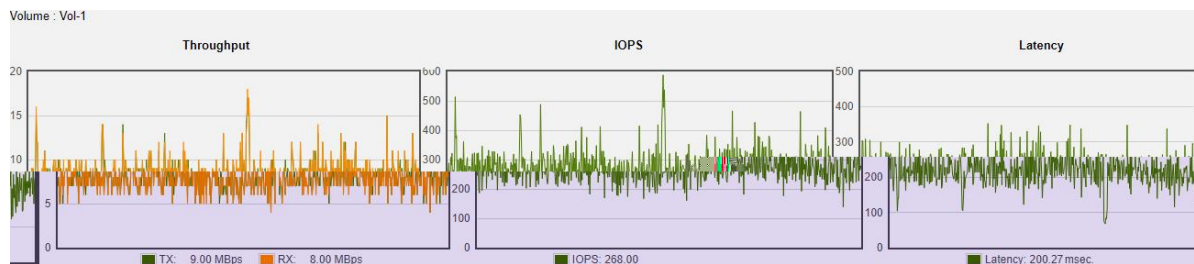

Figure 13-12 Volume Performance Monitoring

13.3.3. iSCSI Port Performance Monitoring

Select the **iSCSI** function tab in the **Performance** function submenu to display TX (Transmission) and RX (Reception) of the iSCSI ports. Check the interfaces which you want to monitor.

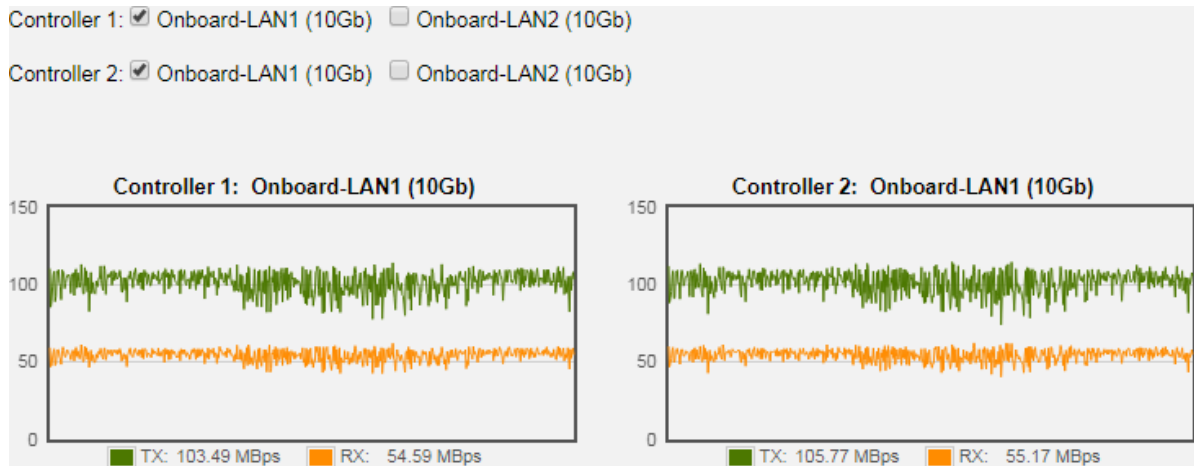

Figure 13-13 iSCSI Performance Monitoring

13.3.4. Fibre Channel Port Monitoring

Select the **Fibre Channel** function tab in the **Performance** function submenu display TX (Transmission) and RX (Reception) of the fibre channels. Check the interfaces which you want to monitor.

14. SED and ISE Support

With data security issues at the time, the company places a high priority on ensuring that sensitive data is protected from unauthorized access. Whether it is due to internal policies or external compliance, access to data remains a matter of high importance for all organizations. These organizations will seek out storage manufacturers that provide a stored data protection method, SED (Self-Encrypting Drive), that has both authentication and encryption features.

In addition, ISE (Instant Secure Erase) drive is designed to protect data on hard disk drives by instantly resetting the drive back to factory settings and changing the encryption key so that any data remaining on the drive is cryptographically erased. This means all data on the drive is permanently and instantly unreadable, as needed.

**INFORMATION:**

SED (Self-Encrypting Drive) and ISE (Instant Secure Erase) drive support is available in SANOS firmware 1.3.0.

14.1. Overview

When disk drives are retired and moved outside from the data center into someone else's hands, the data on those drives is put at significant risk. IT administrators routinely retire drives for a variety of reasons, including:

- Returning drives for warranty, repair, maintenance, or expired lease agreements
- Removal and disposal of disk drives
- Repurposing drives to another storage

Through the study found that almost all drives eventually leave the enterprise or data center, but the corporate data resides on such drives, and when most leave the data center, the data they contain is still readable. Even data that has been striped across many drives in a RAID protection is vulnerable to data theft, because just a typical single stripe in today's high-capacity arrays is large enough to expose the sensitive and secured data.

Drive Control Challenges and Disposal Costs

In an effort to avoid data breaches, corporations have tried many ways to erase the data on retired drives before they leave the houses and potentially fall into the bad guy. Current retirement practices are all expensive and time-consuming, such as:

- Overwriting drive data
- Degaussing or physically shredding
- Hire professional disposal services

These designed to make data unreadable rely on significant human involvement in the process, and are thus subject to both technical and human failure.

The Solution

Every day, thousands of disk drives leave data centers as old systems are retired. But what if all those disk drives had been automatically and transparently encrypting that data, enabling it to be instantly and securely erased? SED comprehensively resolve these issues, making encryption for drive retirement both easy and affordable.

SED has build-in an encryption controller and an encryption key on the disk drive itself. It can provide instant secure erase (cryptographic erase or making the data no longer readable), and to enable auto-locking to secure active data if a drive is misplaced or stolen from a system while in use.

While ISE provides instant secure erase only. When it's time to retire or repurpose the drive, the owner sends a command to the drive to perform a cryptographic erase. Cryptographic erase simply replaces the encryption key inside the encrypted drive, making it impossible to ever decrypt the data encrypted with the deleted key.

Benefits

SED & ISE reduce IT operating expenses by freeing IT from both drive control headaches and disposal costs. By using SED & ISE, they are without hindering IT efficiency.

Furthermore, SED & ISE simplify decommissioning and preserve hardware value for returns and repurposing by:

- Securing warranty and expired lease returns
- Eliminating the need to overwrite or destroy the drive
- Enabling drives to be repurposed securely

In addition, the drive owner may choose to employ the SED in the auto-lock mode to help secure active data against theft. Utilizing the SED in auto-lock mode simply requires securing the drive during its normal use with an authentication key. When secured in this

manner, the drive's data encryption key is locked whenever the drive is powered down. In other words, the moment the SED is switched off or unplugged, it automatically locks down the drive's data.

When the SED is then powered back on, the SED requires authentication before being able to unlock its encryption key and read any data on the drive, thus protecting against misplacement and insider or external theft.

14.2. Theory of Operation

SED has two functions. There are authentication which is operated by AK (Authentication Key) and encryption data which is operated by DEK (Data Encryption Key). ISE drive has encryption data only by DEK but no authentication.

14.2.1. SED Operation Process

An AK is generated by a user entered password. After enabling authentication key successfully, recommend to export the key file to an external media (e.g.: external disk drive, USB drive, etc.) and store it in a safe location. You must be able to use the authentication key file to recover in case of an unforeseen event.



CAUTION:

Recommend backup the key, or you risk losing all data on the SEDs.

A new clean SED is not locked; it has to be written an AK into the SED first. It's called initiate SED. The following describes the steps that occur during the authentication process of a secured drive.

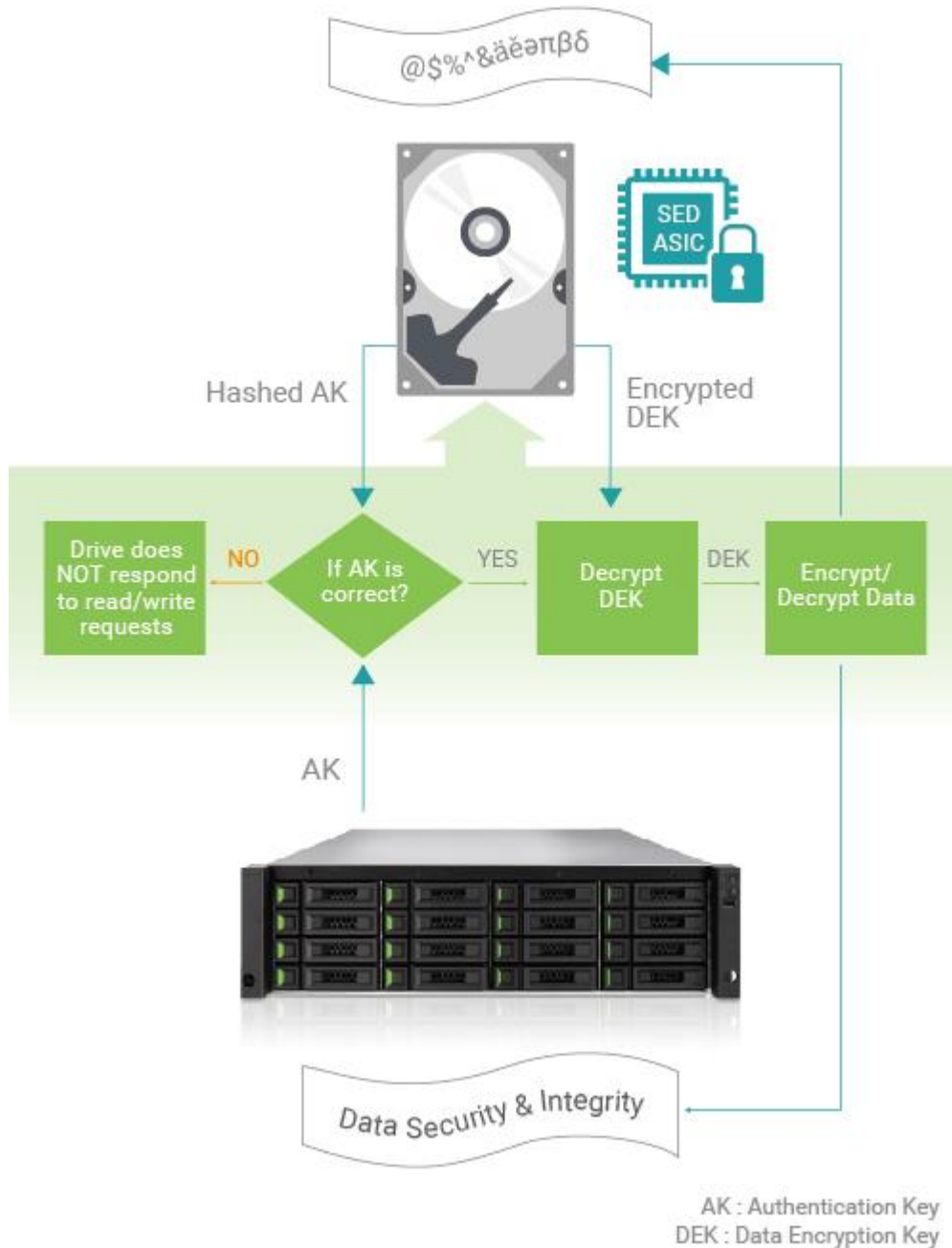

Figure 14-1 SED Operation Process

Authentication

The storage system gets the AK from user entered and sends it to the correct locked drive. The drive hashes the AK and compares the result with the hash of the AK that’s stored in a secure area of the disk. If the two hashed AK values do not match, the authentication

process ends, and the drive will not permit reading data from the disk. The drive remains locked.

Decrypt the DEK

If the two hashes match, the drive is then unlocked, and the drive uses the AK it received from the storage system to decrypt the DEK (which was previously encrypted with the AK) that's stored in a secure area of the disk. Once the authentication process is successfully completed, the drive is unlocked until the next time it is powered down. Note that this authentication process only occurs when the drive is first powered on. It does not repeat with each I/O.

The DEK Encrypts and Decrypts the Data

The DEK is then used to encrypt data to be written to the disk and to decrypt data that's being read from the disk. The drive now works in standard fashion during data transfers, with encryption and decryption transparently occurring in the background.

14.2.2. ISE Technology

Each ISE drive (SED as well) randomly generates an encryption key in the factory that is embedded on the drive. The ISE automatically performs full disk encryption; when a write is performed; clear text enters the drive and is first encrypted (using the DEK embedded within the drive) before being written to the disk. When a read is performed, the encrypted data on the disk is decrypted before leaving the drive. During normal operation an ISE is completely transparent to the system, appearing to be the same as a non-encrypting drive. The self-encrypting is constantly encrypting, encryption cannot be accidentally turned off.

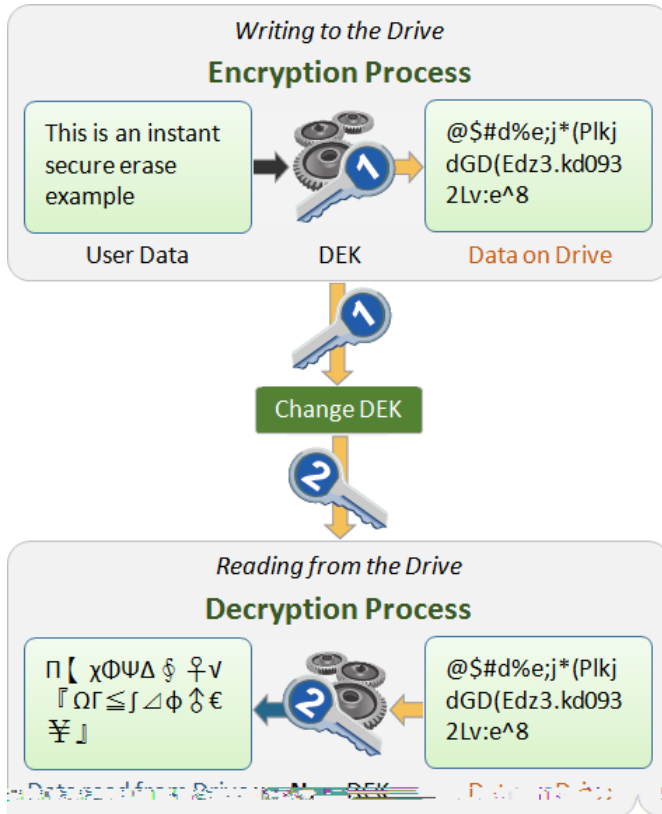

Figure 14-2 ISE Technology

ISE technology greatly simplifies repurposing of the drive and disposal. An owner wishing to repurpose a drive simply performs a key erase to replace the encryption key. The drive deletes the encryption key and replaces it with a new encryption key generated randomly within the drive. After key erase, any data that had been written to the disk is unreadable; data that was encrypted with the previous key is unintelligible when decrypted with the new encryption key. The drive is left as it was delivered from the factory.

Instant Erase Limitation

If ISEs are free and not be used as any pool member, they can be performed instant erase. The same limitation as SEDs, however SEDs can be erased by the AK is enabled. Another case is that the unknown SED is put in lock mode, the way to erase it is to perform erase SED by PSID which is a unique number in each drive, printed on the disk label, and visible to anyone with physical access to the SED. The owner would simply perform a secure erase to replace the encryption key.



INFORMATION:

SEDs or ISE drives can be erased only if their usage status is free.

14.3. Configure Authentication Key

This section will describe the operations of configuring the AK.

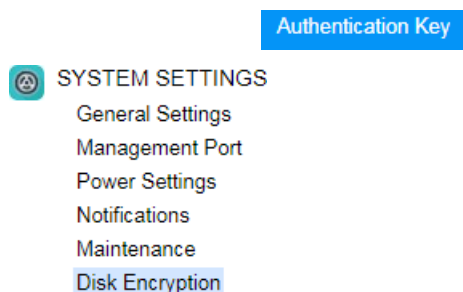

Figure 14-3 Disk Encryption Function Submenu

14.3.1. Operations on Authentication Key

The options are available in this tab.

Enable Authentication Key

Before using SED, you have to enable an AK. Note that all SEDs in the system use this AK. Here is an example of enabling an AK.

1. Select the **Authentication Key** function tab in the **Disk Encryption** function submenu.

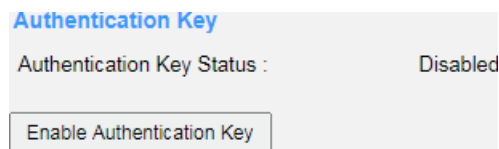

Figure 14-4 Authentication Key is Disabled

2. Click the **Enable Authentication Key** button to enable.

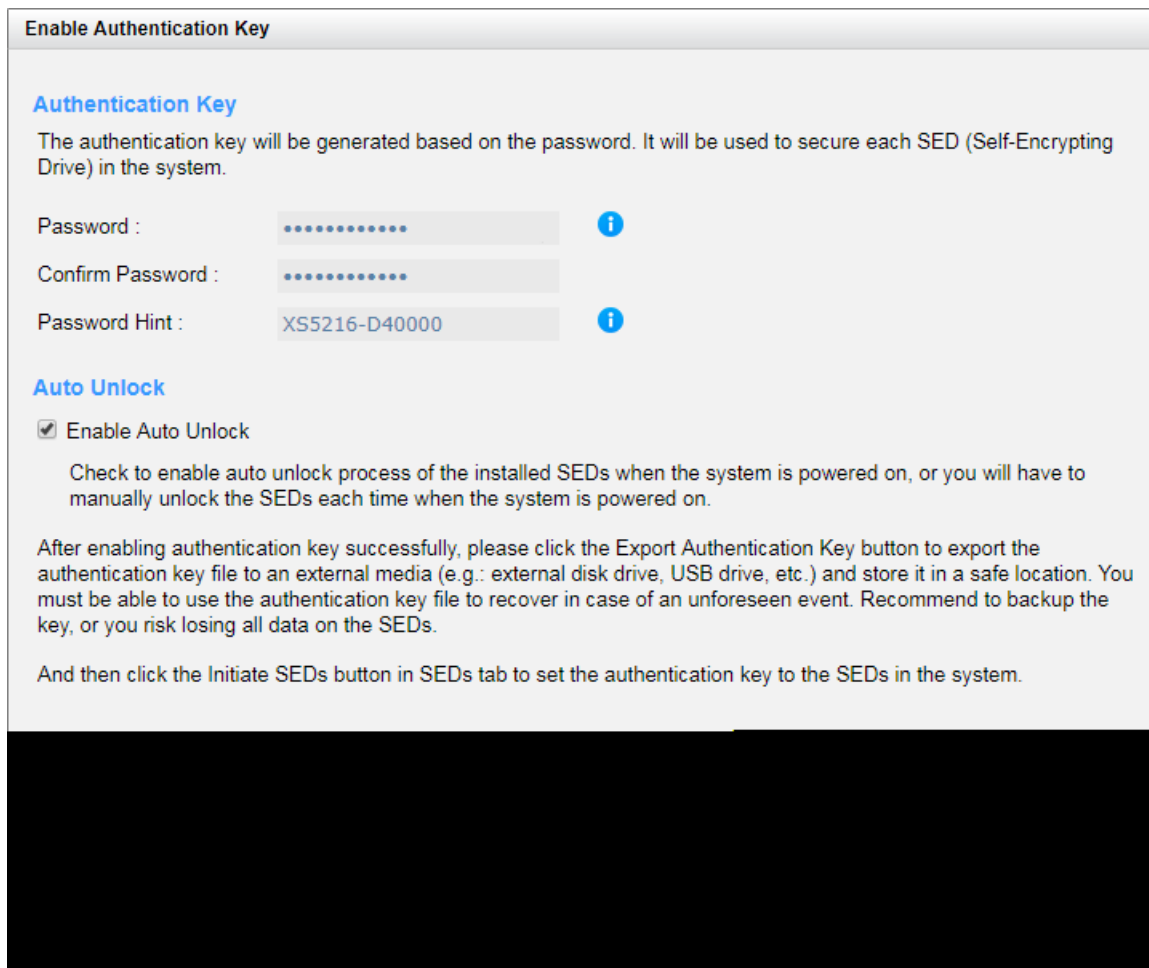

Figure 14-5 Enable Authentication Key

3. Enter a **Password** for generating the AK. The length of the password is between 4 to 12 characters. Valid characters are [A~Z | a~z | 0~9 | ~!@#\$%^&* _-+=`|\(){}[];:"<>.,?/]. And enter it again at **Confirm Password**.
4. Enter a **Password Hint**. It is the AK hint for recognizing the system. The default value is system name and can be changed. The maximum length of the password hint is 32 characters. Valid characters are [A~Z | a~z | 0~9 | _-].
5. Check the **Enable Auto Unlock** option will enable auto unlock process of the installed SEDs when the system is powered on, or you will have to manually unlock the SEDs each time when the system is powered on. The default value is enabled.
6. Click the **OK** button to enable.

Authentication Key

Authentication Key Status :	Enabled
Total Quantity of SED :	4
Quantity of Enabled SED :	0
Quantity of Locked SED :	0
Quantity of Disabled SED :	4
Quantity of Password Locked SED :	0
Quantity of Unknown SED :	0
Quantity of SED Pool :	0

Auto Unlock

Enable Auto Unlock

Check to enable auto unlock process of the installed SEDs when the system is powered on, or you will have to manually unlock the SEDs each time when the system is powered on.

Figure 14-6 Authentication Key is Enabled

After the AK is enabled fully, there are SED summary displayed in the page. In addition, **Auto Unlock** option can also be changed here. You can uncheck the **Enable Auto Unlock** option and then click the **Apply** button to take effect.

Export Authentication Key

After enabling the AK successfully, please click the **Export Authentication Key** button to export the AK file to an external media (e.g.: external disk drive, USB drive, etc.) and store it in a safe location. You must be able to use the AK file to recover in case of an unforeseen event.



CAUTION:

Recommend backup the key, or you risk losing all data on the SEDs.

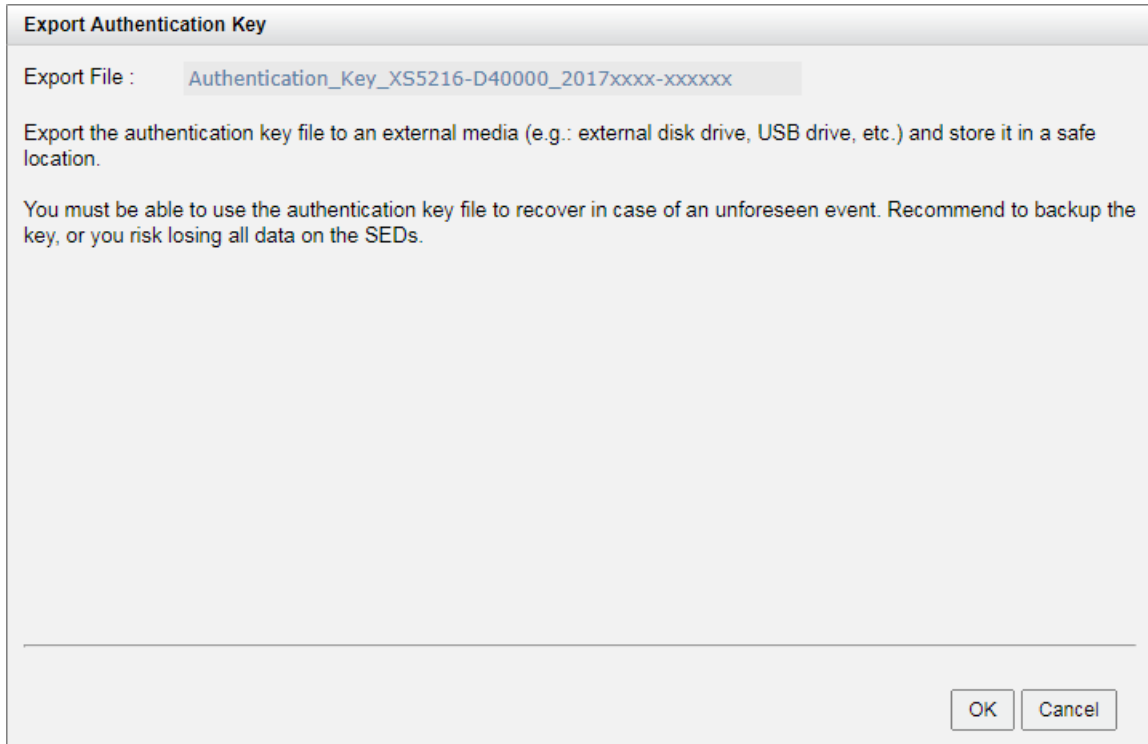

Figure 14-7 Export Authentication Key

1. Enter an **Export File** name to export the AK file. The default value is the password hint plus date and time.
2. Click the **OK** button to export.

Change Authentication Key

Click the **Change Authentication Key** button to change the AK. Before changing the AK, please stop all I/O of the encryption pools within the SEDs. The new AK will be regenerated based on the new password and set the new authentication key to all enabled SEDs in the system. If the I/O are still running, it may risk losing data during changing the AK. Here is an example of changing the AK.

1. Click the **Change Authentication Key** button to change.

Change Authentication Key

Please stop all I/O of the encryption pools within the SEDs. The new authentication key will be regenerated based on the new password and set the new authentication key to all enabled SEDs in the system. If the I/O are still running, it may risk losing data during changing the authentication key.

New Password : i

Confirm New Password :

Password Hint : i

After changing authentication key successfully, please click the Export Authentication Key button to export the authentication key file to an external media (e.g.: external disk drive, USB drive, etc.) and store it in a safe location. You must be able to use the authentication key file to recover in case of an unforeseen event. Recommend to backup the key, or you risk losing all data on the SEDs.

Figure 14-8 Change Authentication Key

2. Change the **Password** for generating the AK. The length of the password is between 4 to 12 characters. Valid characters are [A~Z | a~z | 0~9 | ~!@#\$%^&*_-+=`|\(){}[];":'<>.,?/]. And enter it again at **Confirm Password**.
3. Change the **Password Hint** if necessary. The maximum length of the password hint is 32 characters. Valid characters are [A~Z | a~z | 0~9 | _-].
4. Click the **OK** button to change. If there are enabled SEDs in the system, the system will change them one by one and display the results.

Disable Authentication Key

If you no longer use disk encryption and there are no encryption pools within the SEDs. The AK can be disabled. Click the **Disable Authentication Key** button to disable it.

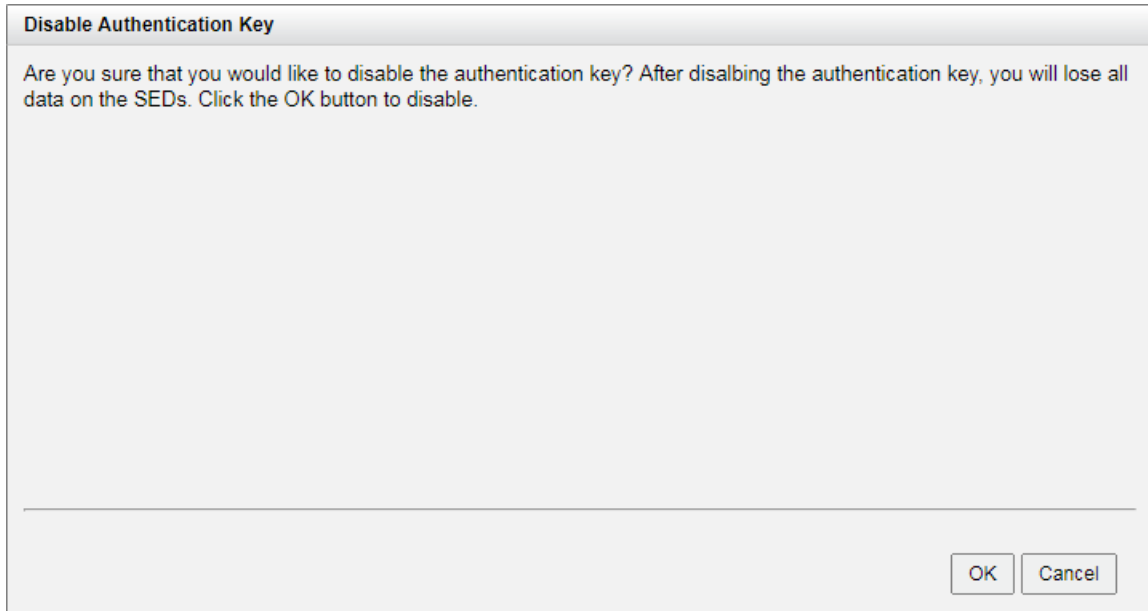

Figure 14-9 Disable Authentication Key

Click the **OK** button to confirm.



TIP:

The **Disable Authentication Key** function can be operated when there is no encryption pools within the SEDs and the SED status of all SEDs is disabled or unknown.

14.4. Configure SEDs

The **SEDs** function tab in the **Disk Encryption** function submenu is only visible when the AK is enabled. Select the **SEDs** function tab to display the status of SEDs, initiate SEDs, unlock SEDs, or erase SEDs.

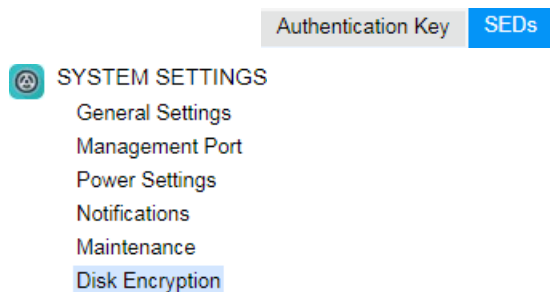

Figure 14-10 Disk Encryption Function Submenu

14.4.1. List SEDs

The drop-down lists at the top enable you to select the enclosure from head unit (SAN system) or expansion units (expansion enclosures).

INFORMATION:

Enclosure format: Enclosure ID ([Head Unit | Expansion Unit]: Model Name). For example: 0 (Head Unit: XS5216), 1 (Expansion Unit: XD5316)

Enclosure ID: 0 (Head Unit: XS3216) ▼

	Slot	Status	Health	SED Status	Capacity	Disk Type	Usage	Pool Name	Manufacturer	Model
▼	1	Online	Good	Disabled	92.91 GB	SAS SSD 12.0Gb/s	Free		HGST	HUSMH8010BSS205
▼	2	Online	Good	Disabled	92.91 GB	SAS SSD 12.0Gb/s	Free		HGST	HUSMH8010BSS205
▼	3	Online	Good	Disabled	92.91 GB	SAS SSD 12.0Gb/s	Free		HGST	HUSMH8010BSS205
▼	4	Online	Good	Disabled	92.91 GB	SAS SSD 12.0Gb/s	Free		HGST	HUSMH8010BSS205

Initiate SEDs
Unlock SEDs
Erase SEDs

Figure 14-11 List SEDs

This table shows the column descriptions.

Table 14-1 Disk Column Descriptions

Column Name	Description
Slot	The position of the disk drive.
Status	The status of the disk drive: <ul style="list-style-type: none"> Online: The disk drive is online. Rebuilding: The disk drive is being rebuilt. Transitioning: The disk drive is being migrated or is replaced by

	<p>another disk when rebuilding occurs.</p> <ul style="list-style-type: none"> • Scrubbing: The disk drive is being scrubbed. • Check Done: The disk drive has been checked the disk health. • Copying Back: The disk drive is being copied back.
Health	<p>The health of the disk drive:</p> <ul style="list-style-type: none"> • Good: The disk drive is good. • Failed: The disk drive has failed. • Error Alert: S.M.A.R.T. error alerts. • Read Errors: The disk drive has unrecoverable read errors.
SED Status	<p>The status of the SED:</p> <ul style="list-style-type: none"> • Enabled: The SED is enabled. • Locked: The SED is locked. It must be unlocked by the correct AK before it can be used. • Disabled: The SED is disabled. It must be initiated before it can be used. • Password Locked: The SED is locked by entering the incorrect password too many times. • Unknown: The SED is unknown. • Initiating: The SED is being initiated. • Unlocking: The SED is being unlocked. • Erasing: The SED is being erased. • Changing Key: The SED is being changed the key.
Capacity	The capacity of the disk drive.
Disk Type	<p>The type of the disk drive:</p> <ul style="list-style-type: none"> • [SAS HDD NL-SAS HDD SAS SSD SATA SSD] • [12.0Gb/s 6.0Gb/s 3.0Gb/s 1.5Gb/s]
Usage	<p>The usage of the disk drive:</p> <ul style="list-style-type: none"> • Free: This disk drive is free for use. • RAID: This disk drive has been set to a pool. • SSD Cache: This SSD has been set to an SSD cache pool. • Dedicated Spare: This disk drive has been set as dedicated spare of a pool. • Local Spare: This disk drive has been set as local spare of the enclosure. • Global Spare: This disk drive has been set as global spare of whole system. • SSD Spare: This SSD has been set as dedicated SSD spare of an SSD cache pool.

Pool Name	Which pool the disk drive belongs to.
Manufacturer	The manufacturer of the disk drive.
Model	The model name of the disk drive.

14.4.2. Operations on SEDs

The options are available in this tab:

Initiate SEDs

Click the **Initiate SEDs** button to initiate the selected SEDs. And then click the **OK** button to proceed.

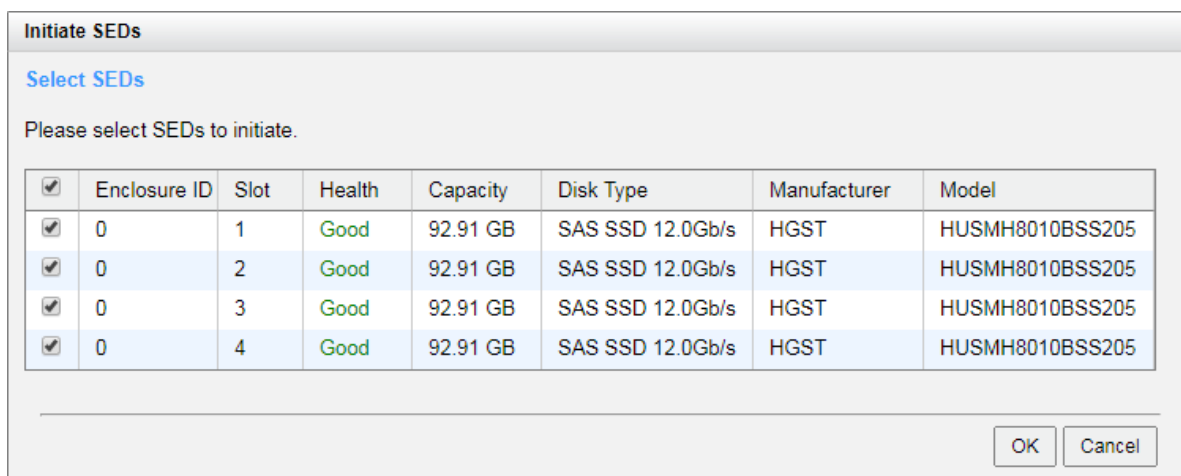

Figure 14-12 Initiate SEDs

After proceeding, it will pop up a window to display the results.

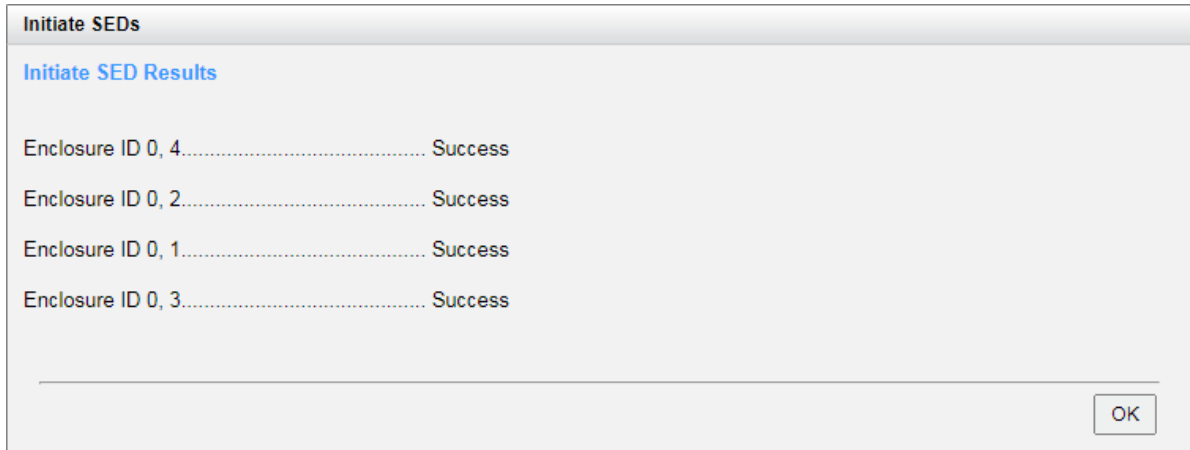

Figure 14-13 Initiate SED Results

If the results are successful, the SED status will become **Enabled**.

Enclosure ID: 0 (Head Unit: XS3216)

Slot	Status	Health	SED Status	Capacity	Disk Type	Usage	Pool Name	Manufacturer	Model
1	Online	Good	Enabled	92.91 GB	SAS SSD 12.0Gb/s	Free		HGST	HUSMH8010BSS205
3	Online	Good	Enabled	92.91 GB	SAS SSD 12.0Gb/s	Free		HGST	HUSMH8010BSS205

Figure 14-14 List SEDs



INFORMATION:

The **Initiate SEDs** function can be operated when the usage status of SEDs is free and the SED status is **Disabled**.

Unlock SEDs

Click the **Unlock SEDs** button to unlock the selected SEDs. Please select a method to unlock the SEDs. And then click the **OK** button to proceed.

Unlock SEDs

Authentication Key

Please select a method of authentication key to unlock the SEDs. If the SEDs are roamed from other systems, they will be unlocked with their authentication keys, and then being replaced by the authentication key of the current system.

Use the Authentication Key of the Current System
 Enter an Authentication Key Password
 Password
 Import an Authentication Key File

Select SEDs

Please select the SEDs to be unlocked.

<input checked="" type="checkbox"/>	Password Hint	Enclosure ID	Slot	Health	Capacity	Disk Type	Manufacturer	Model
<input checked="" type="checkbox"/>	XS5216-D40000	0	1	Good	92.91 GB	SAS SSD 12.0Gb/s	HGST	HUSMH8010BSS205
<input checked="" type="checkbox"/>	XS5216-D40000	0	2	Good	92.91 GB	SAS SSD 12.0Gb/s	HGST	HUSMH8010BSS205
<input checked="" type="checkbox"/>	XS5216-D40000	0	3	Good	92.91 GB	SAS SSD 12.0Gb/s	HGST	HUSMH8010BSS205
<input checked="" type="checkbox"/>	XS5216-D40000	0	4	Good	92.91 GB	SAS SSD 12.0Gb/s	HGST	HUSMH8010BSS205

Figure 14-15 Unlock SEDs

You can select the **Use the Authentication Key of the Current System** to unlock the SEDs. Or if the SEDs are roamed from other systems, they will be unlocked with their AKs, and then being replaced by the AK of the current system. In this case, please select the **Enter an Authentication Key Password** or **Import and Authentication Key File** to unlock the SED.



INFORMATION:

The **Unlock SEDs** function can be operated when the SED status of SEDs is **Locked**.

Erase SEDs

If there are no encryption pools within the SEDs, these SEDs can be erased. Click the **Erase SEDs** button to erase the selected SEDs. And then click the **OK** button to proceed.

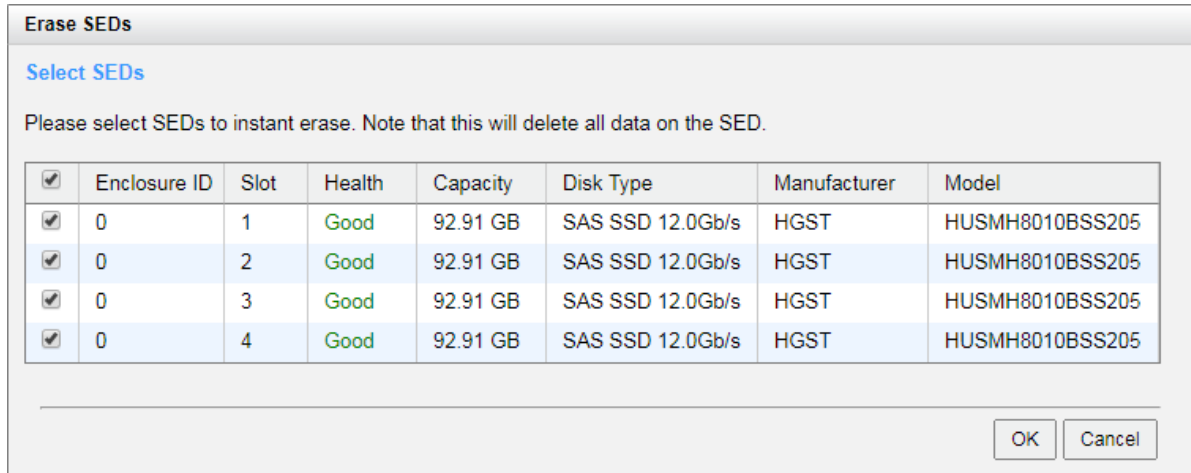

Figure 14-16 Erase SEDs

After proceeding, it will pop up a window to display the results. If the results are successful, the SED status will become **Disabled**.



INFORMATION:

The **Erase SEDs** function can be operated when the usage status of SEDs is free.



CAUTION:

Erasing the SEDs will change the DEK and delete all data on the SED. The data on SED can never be restored, please exercise caution.

Erase SED by PSID

If you don't know where the SED comes from, or the status of the SED is unknown and you don't know its password. The last method is to erase the SED by PSID (Physical Secure ID) which is on the label of the disk drive. Click ▼ -> **Erase SED by PSID** to erase the SED by PSID.

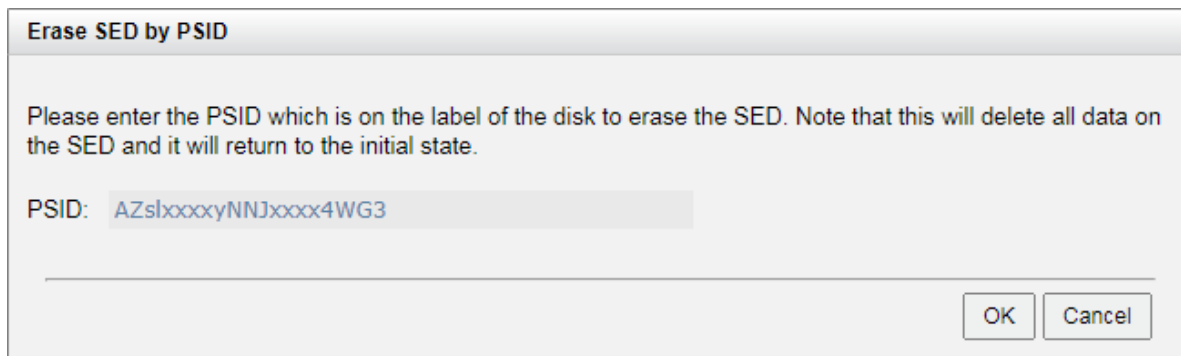

Figure 14-17 Erase SED by PSID



INFORMATION:

The **Erase SED by PSID** function can be operated when the usage status of the SED is free.



CAUTION:

Erasing the SED by PSID will delete all data on the SED and it will return to the initial state. The data on SED can never be restored, please exercise caution.

14.5. Configure SED Pools

This section will describe the operations of configuring an SED pool.

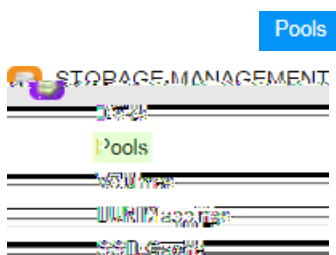

Figure 14-18 Pools Function Submenu

14.5.1. Create an SED Pool

Here is an example of creating an SED pool with 3 SEDs configured in RAID 5. At the first time of creating a pool, it contains a disk group and the maximum quantity of disk in a disk group is 64.

1. Select the **Pools** function submenu, click the **Create Pool** button. It will scan available disks first.



TIP:

It may take 20 ~ 30 seconds to scan disks if your system has more than 200 disk drives. Please wait patiently.

The screenshot shows the 'Create Pool' configuration window. On the left is a sidebar with 'General' selected. The main area is divided into sections: 'Pool Type' with radio buttons for 'Thick Provisioning' (selected), 'Thin Provisioning', and 'Auto Tiering (Thin Provisioning Enabled)'; 'Pool Properties' with text input for 'Pool Name' (Pool-4) and a dropdown for 'Preferred Controller' (Controller 1); and 'SED Pool' with a checked checkbox for 'Enable SED Pool'. A red box highlights the 'Enable SED Pool' checkbox. Below it is a note: 'Enabling SED pool will use the secure SEDs to create a pool. Intermixing SEDs and non-SEDs are not supported in a pool.' At the bottom right are 'Next' and 'Cancel' buttons.

Figure 14-19 Create an SED Pool Step 1

2. Select a **Pool Type**.
3. Enter a **Pool Name** for the pool. The maximum length of the pool name is 16 characters. Valid characters are [A~Z | a~z | 0~9 | -_<>].

4. Select a **Preferred Controller** from the drop-down list. The backend I/O resources in this pool will be processed by the preferred controller which you specified. This option is available when dual controllers are installed.
5. Check the **Enable SED Pool** checkbox. Enabling SED pool will use the secure SEDs to create a pool. Intermixing SEDs and non-SEDs are not supported in a pool.
6. Click the **Next** button to continue.

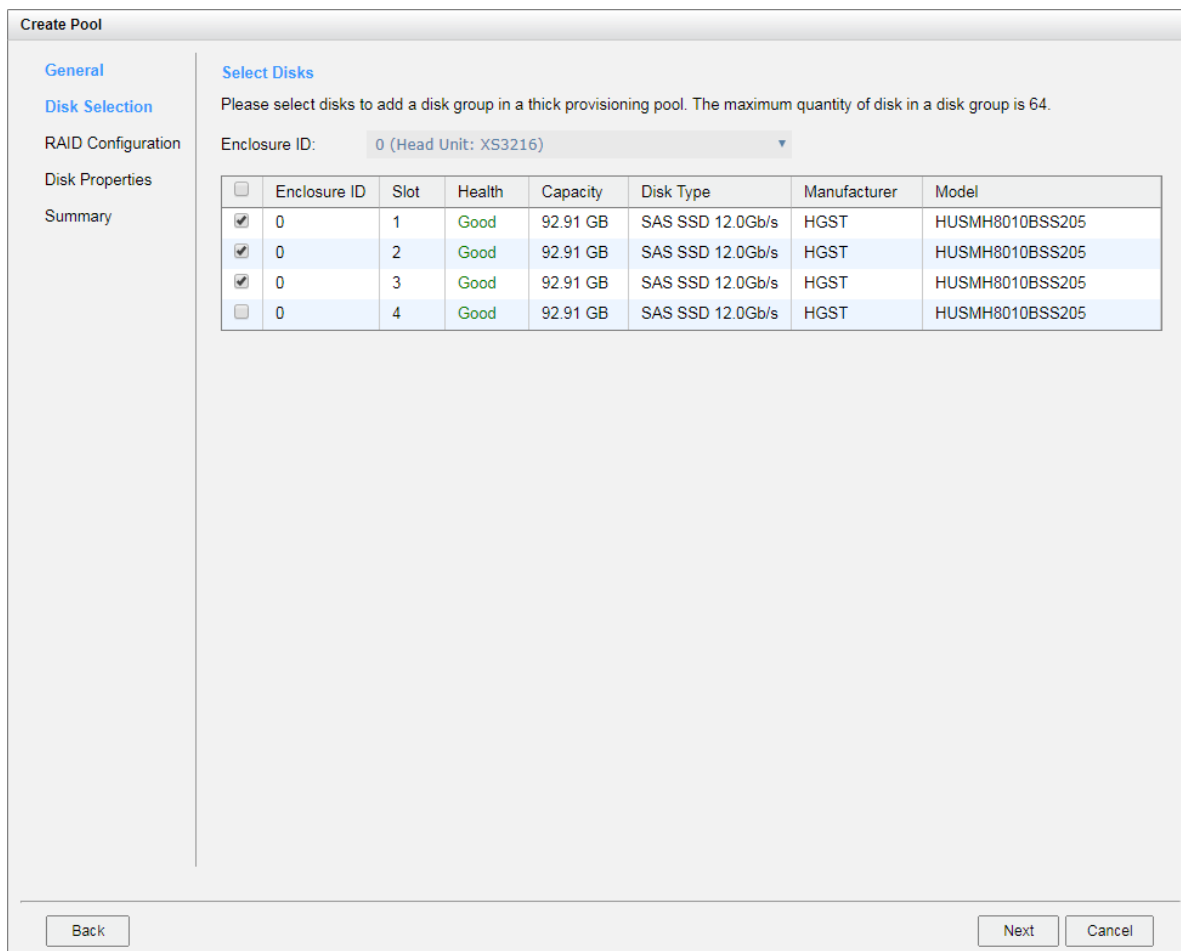

Figure 14-20 Create an SED Pool Step 2

7. Please select disks for pool. The maximum quantity of disk in a disk group is 64. Select an **Enclosure ID** from the drop-down list to select disks from expansion enclosures.
8. Click the **Next** button to continue.

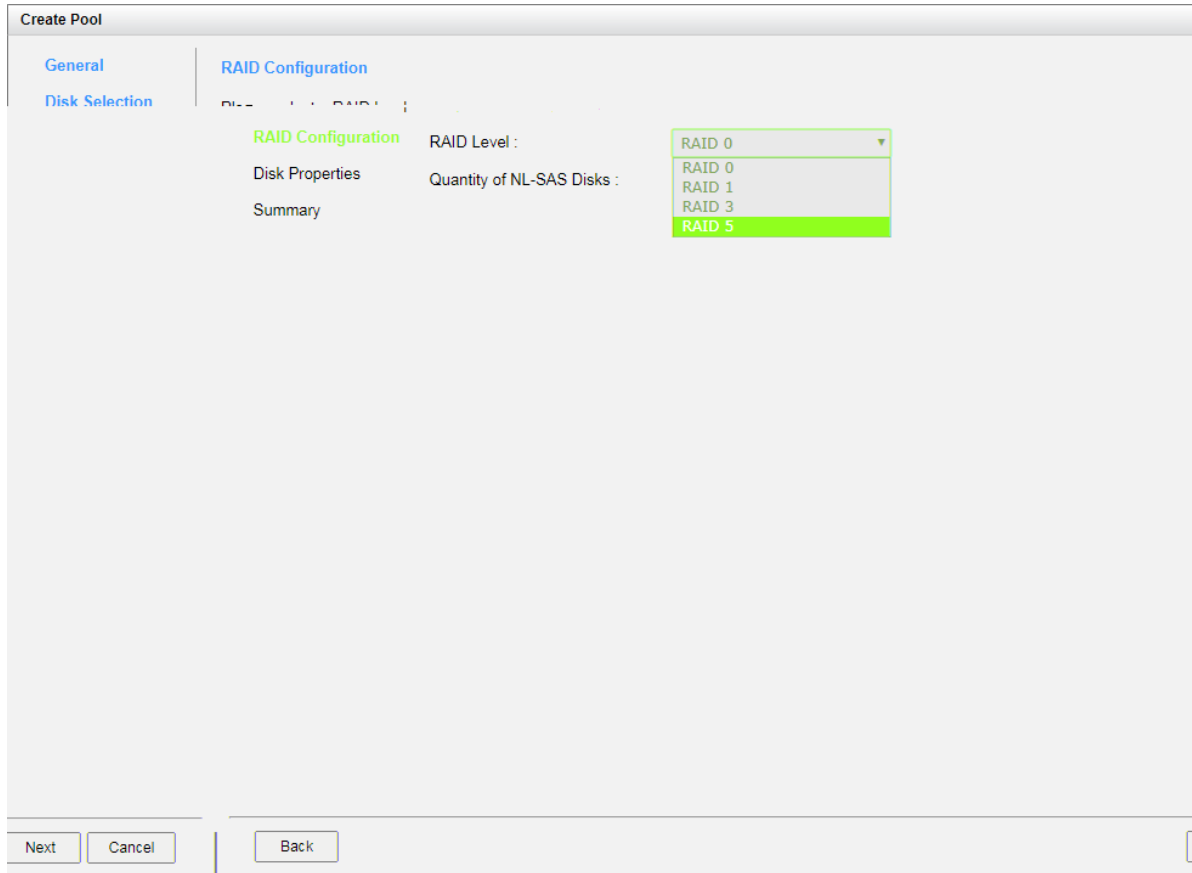

Figure 14-21 Create an SED Pool Step 3

9. Select a **RAID Level** from the drop-down list which lists available RAID level only according to the disk selection. And also select a **Quantity of Subgroups** if the combination RAID level is selected.
10. Click the **Next** button to continue.

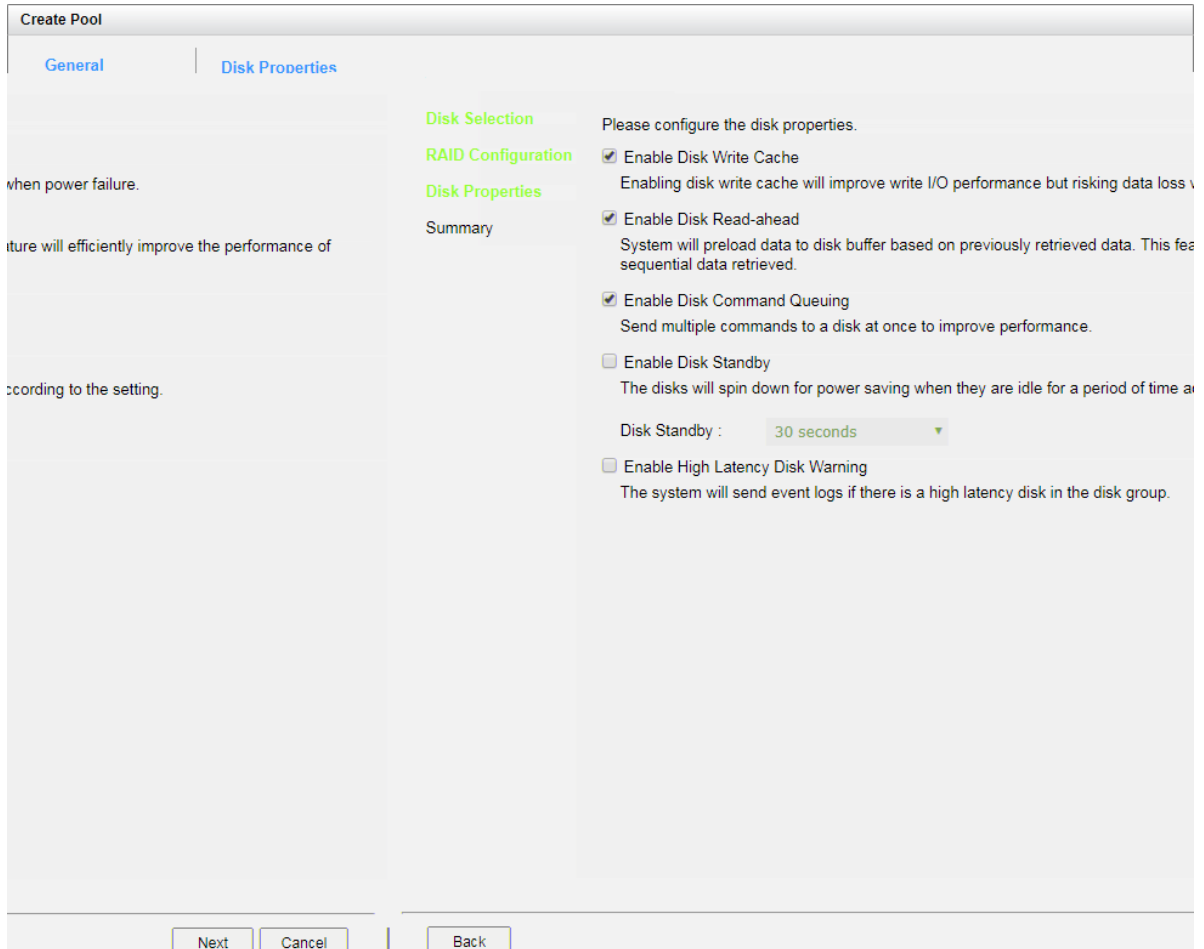

Figure 14-22 Create an SED Pool Step 4

11. Disk properties can also be configured optionally in this step:

Enable Disk Write Cache: Check to enable the write cache option of disks. Enabling disk write cache will improve write I/O performance but have a risk of losing data when power failure.

Enable Disk Read-ahead: Check to enable the read-ahead function of disks. System will preload data to disk buffer based on previously retrieved data. This feature will efficiently improve the performance of sequential data retrieved.

Enable Disk Command Queuing: Check to enable the command queue function of disks. Send multiple commands to a disk at once to improve performance.

Enable Disk Standby: Check to enable the auto spin down function of disks. The disks will be spun down for power saving when they are idle for the period of time specified.

Enable High Latency Disk Warning: Check to enable the high latency disk warning function in a disk group. When a disk drive is abnormal with high latency, the system

will send event logs to notify IT administrators in advance to avoid affecting overall performance.

12. Click the **Next** button to continue.

Create Pool

General

Pool Properties

Pool Type : Thick Provisioning

Pool Name : Pool-4

Preferred Controller : Controller 1

RAID Configuration

RAID Level : RAID 5

Quantity of SAS Disks : 3

Disk Properties

Disk Write Cache : Enabled

Disk Read-ahead : Enabled

Disk Command Queuing : Enabled

Disk Standby : Disabled

High Latency Disk Warning : Disabled

Back Finish Cancel

Figure 14-23 Create an SED Pool Step 5

13. After confirmation of info on the summary page, click the **Finish** button to create a pool.

	Pool Name	Status	Health	Total	Free	Available	Thin Provisioning	Auto Tiering	Encryption	Volumes	Current Controller
▼	Pool-4	Online	Good	185.82 GB	185.82 GB	185.82 GB	Disabled	Disabled	Enabled	0	Controller 1

Create Pool

Figure 14-24 An SED Pool is Created

14. An SED pool has been created. If necessary, click the **Create Pool** button again to create others.

14.5.2. List SED Pools

Click a pool; it will display the related disk groups. Similarly, click a disk group; it will display the related disk drives. The pool properties can be configured by clicking the functions button ▼ to the left side of the specific pool.

	Pool Name	Status	Health	Total	Free	Available	Thin Provisioning	Auto Tiering	Encryption	Volumes	Current Controller
▼	Pool-4	Online	Good	185.82 GB	185.82 GB	185.82 GB	Disabled	Disabled	Enabled	0	Controller 1

Disk Groups

	No.	Status	Health	Total	Free	RAID	Disks Used	RAID 2.0 Spare
▼	1	Online	Good	185.00 GB	185.00 GB	RAID 5	3	N/A

Disks

Enclosure ID	Slot	Status	Health	Capacity	Disk Type	Manufacturer	Model
0	1	Online	Good	92.91 GB	SAS SSD 12.0Gb/s	HGST	HUSMH8010BSS205
0	2	Online	Good	92.91 GB	SAS SSD 12.0Gb/s	HGST	HUSMH8010BSS205
0	3	Online	Good	92.91 GB	SAS SSD 12.0Gb/s	HGST	HUSMH8010BSS205

Create Pool

Figure 14-25 List SED Pools

This table shows the column descriptions.

Table 14-2 Pool Column Descriptions

Column Name	Description
Pool Name	The pool name.
Status	The status of the pool: <ul style="list-style-type: none"> • Online: The pool is online. • Offline: The pool is offline. • Rebuilding: The pool is being rebuilt. • Migrating: The pool is being migrated. • Relocating: The pool is being relocated. • EE Rebuilding: The pool is being RAID EE rebuilt.
Health	The health of the pool: <ul style="list-style-type: none"> • Good: The pool is good. • Failed: The pool has failed.

	<ul style="list-style-type: none"> • Degraded: The pool is unhealthy and incomplete. The cause may be a disk loss or failure.
Total	Total capacity of the pool.
Free	Free capacity of the pool.
Available	Available capacity of the pool.
Thin Provisioning	The status of Thin provisioning: <ul style="list-style-type: none"> • Disabled: The pool is thick provisioned. • Enabled: The pool is thin provisioned.
Auto Tiering	The status of Auto Tiering: <ul style="list-style-type: none"> • Disabled: The pool is auto tiering disabled. • Enabled: The pool is auto tiering enabled. • Not Supported: The pool contains the disk groups with mixed disk type.
Encryption	The Data Secure Mode: <ul style="list-style-type: none"> • Disabled: The pool is not encrypted. • Enabled: The pool is encrypted.
Volumes	The quantity of volumes in the pool.
Current Controller (This option is only visible when dual controllers are installed.)	The current running controller of the pool.

Table 14-3 Disk Group Column Descriptions

Column Name	Description
No	The number of disk group.
Status	The status of the disk group: <ul style="list-style-type: none"> • Online: The disk group is online. • Offline: The disk group is offline. • Rebuilding: The disk group is being rebuilt. • Migrating: The disk group is being migrated. • Relocating: The disk group is being relocated. • EE Rebuilding: The disk group is being RAID EE rebuilt.
Health	The health of the disk group: <ul style="list-style-type: none"> • Good: The disk group is good. • Failed: The disk group has failed.

	<ul style="list-style-type: none"> • Degraded: The disk group is not healthy and not completed. The reason could be lack of disk(s) or have failed disk.
Total	Total capacity of the disk group.
Free	Free capacity of the disk group.
RAID	The RAID level of the disk group.
Disks Used	The quantity of disk drives in the disk group.
RAID 2.0 Spare	The quantity of RAID 2.0 spare disk drives in the disk group. Display N/A is the RAID level is traditional.

Table 14-4 Disk Column Descriptions

Column Name	Description
Enclosure ID	The enclosure ID.
Slot	The position of the disk drive.
Status	The status of the disk drive: <ul style="list-style-type: none"> • Online: The disk drive is online. • Missing: The disk drive is missing in the pool. • Rebuilding: The disk drive is being rebuilt. • Transitioning: The disk drive is being migrated or is replaced by another disk when rebuilding occurs. • Scrubbing: The disk drive is being scrubbed. • Check Done: The disk drive has been checked the disk health. • Copying Back: The disk drive is being copied back.
Health	The health of the disk drive: <ul style="list-style-type: none"> • Good: The disk drive is good. • Failed: The disk drive has failed. • Error Alert: S.M.A.R.T. error alerts. • Read Errors: The disk drive has unrecoverable read errors.
Capacity	The capacity of the disk drive.
Disk Type	The type of the disk drive: <ul style="list-style-type: none"> • [SAS HDD NL-SAS HDD SAS SSD SATA SSD] • [12.0Gb/s 6.0Gb/s 3.0Gb/s 1.5Gb/s]
Manufacturer	The manufacturer of the disk drive.
Model	The model name of the disk drive.

14.5.3. Operations on SED Pools

Most operations are described in the Configuring Storage Pools section. For more information, please refer to the chapter 8.4.3, [Operations on Thick Provisioning Pools](#) section. We describe the restrictions about SED pool in the following.

Add a Disk Group

Click ▼ -> **Add Disk Group** to add a disk group. Disks can only choose SEDs. Select SEDs and then click the **OK** button.

Move Disk Group Member Disks

Click ▼ -> **Move Disk Group** in disk group to move the member SEDs of the disk group to other SEDs. They cannot move to non SED. Select SEDs and then click the **OK** button.

14.5.4. Rebuild on SED Pools

Rebuilding an SED pool will use SED as spare disk, whether it is from global, local, or dedicated spare.

14.5.5. Create an SSD Cache Pool on SED Pools

Most operations are described in the SSD Cache chapter. For more information, please refer to the chapter 10.3.2, [Create an SSD Cache Pool](#) section. We describe the restrictions about creating an SSD cache pool on an SED pool in the following.

Create an SSD Cache Pool

Select the **SSD Cache** function submenu; click the **Create SSD Cache Pool** button. It will scan available SSDs with SED only.

14.5.6. Data Backup on Encrypted Volumes

Most operations are described in the Data Backup chapter. For more information, please refer to the chapter 12, [Data Backup](#) chapter. We describe the tips about data backup on encrypted volumes in the following.

Local Clone on Encrypted Volume

If executing local clone from an encrypted volume to a non-encrypted volume, it will pop up a warning message.

Remote Replication on Encrypted Volume

If executing remote replication from an encrypted volume, It will pop up a warning message.

14.6. Configure ISE Drives

Select the **Disks** function submenu to display the status of the SED and ISE drives.

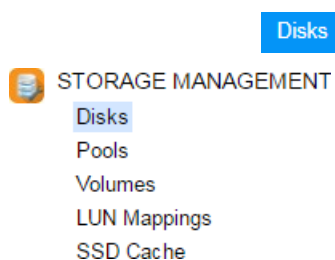

Figure 14-26 Disks Function Submenu

This section will describe the operations of configuring ISE drives. They can only be operated by instant erased.

14.6.1. List ISE Drives

The drop-down lists at the top enable you to select the enclosure from head unit (SAN system) or expansion units (expansion enclosures). The disk properties can be configured by clicking the functions button ▼ to the left side of the specific disk drive.



INFORMATION:

Enclosure format: Enclosure ID ([Head Unit | Expansion Unit]: Model Name). For example: 0 (Head Unit: XS5216), 1 (Expansion Unit: XD5316)

Enclosure ID: 0 (Head Unit: XS3216)

	Slot	Status	Health	Encryption	SED / ISE Status	Capacity	Disk Type	Usage	Pool Name	Manufacturer	Model
▼	1	Online	Good	SED	Enabled	92.91 GB	SAS SSD 12.0Gb/s	Free		HGST	HUSMH8010BSS205
▼	2	Online	Good	SED	Enabled	92.91 GB	SAS SSD 12.0Gb/s	Free		HGST	HUSMH8010BSS205
▼	3	Online	Good	SED	Enabled	92.91 GB	SAS SSD 12.0Gb/s	Free		HGST	HUSMH8010BSS205
▼	4	Online	Good	SED	Enabled	92.91 GB	SAS SSD 12.0Gb/s	Free		HGST	HUSMH8010BSS205
▼	5	Online	Good	ISE	Normal	10.91 TB	NL-SAS HDD 12.0Gb/s	Free		HGST	HUH721212AL5200
▼	6	Online	Good	ISE	Normal	10.91 TB	NL-SAS HDD 12.0Gb/s	Free		HGST	HUH721212AL5200
▼	7	Online	Good	ISE	Normal	10.91 TB	NL-SAS HDD 12.0Gb/s	Free		HGST	HUH721212AL5200
▼	8	Online	Good	ISE	Normal	10.91 TB	NL-SAS HDD 12.0Gb/s	Free		HGST	HUH721212AL5200

Figure 14-27 List SEDs and ISE Drives

This table shows the column descriptions.

Table 14-5 Disk Column Descriptions

Column Name	Description
Slot	The position of the disk drive.
Status	The status of the disk drive: <ul style="list-style-type: none"> • Online: The disk drive is online. • Rebuilding: The disk drive is being rebuilt. • Transitioning: The disk drive is being migrated or is replaced by another disk when rebuilding occurs. • Scrubbing: The disk drive is being scrubbed. • Check Done: The disk drive has been checked the disk health. • Copying Back: The disk drive is being copied back.
Health	The health of the disk drive: <ul style="list-style-type: none"> • Good: The disk drive is good. • Failed: The disk drive has failed. • Error Alert: S.M.A.R.T. error alerts. • Read Errors: The disk drive has unrecoverable read errors.
Encryption	The data security mode of the disk drive: <ul style="list-style-type: none"> • SED: The disk drive is a Self-Encrypting Drive. • ISE: The disk drive is an Instant Secure Erase drive. • None: The disk drive does not have encryption function.
SED / ISE Status	The status of the SED: <ul style="list-style-type: none"> • Enabled: The SED is enabled. • Locked: The SED is locked. It must be unlocked by the correct AK before it can be used. • Disabled: The SED is disabled. It must be initiated before it can be used.

	<ul style="list-style-type: none"> • Password Locked: The SED is locked by entering the incorrect password too many times. • Unknown: The SED is unknown. • Initiating: The SED is being initiated. • Unlocking: The SED is being unlocked. • Erasing: The SED is being erased. • Changing Key: The SED is being changed the key. <p>The status of the ISE:</p> <ul style="list-style-type: none"> • Normal: The ISE is normal. • Erasing: The ISE is being erased. • Unknown: The ISE is unknown. <p>The status of the Non SED/ISE:</p> <ul style="list-style-type: none"> • N/A: The field is not applicable.
Capacity	The capacity of the disk drive.
Disk Type	<p>The type of the disk drive:</p> <ul style="list-style-type: none"> • [SAS HDD NL-SAS HDD SAS SSD SATA SSD] • [12.0Gb/s 6.0Gb/s 3.0Gb/s 1.5Gb/s]
Usage	<p>The usage of the disk drive:</p> <ul style="list-style-type: none"> • Free: This disk drive is free for use. • RAID: This disk drive has been set to a pool. • SSD Cache: This SSD has been set to an SSD cache pool. • Dedicated Spare: This disk drive has been set as dedicated spare of a pool. • Local Spare: This disk drive has been set as local spare of the enclosure. • Global Spare: This disk drive has been set as global spare of whole system. • SSD Spare: This SSD has been set as dedicated SSD spare of an SSD cache pool.
Pool Name	Which pool the disk drive belongs to.
Manufacturer	The manufacturer of the disk drive.
Model	The model name of the disk drive.

14.6.2. Operations on ISE Drives

Most operations are described in the Working with Disk Drives section. For more information, please refer to the chapter 8.3, [Working with Disk Drives](#) section. We describe the operations about an ISE drive in the following.

Instant Erase

If there are no pools within the ISE drives, these ISE drives can be erased. Click the **Instant Erase** button to erase the selected ISEs. And then click **OK** button to proceed.

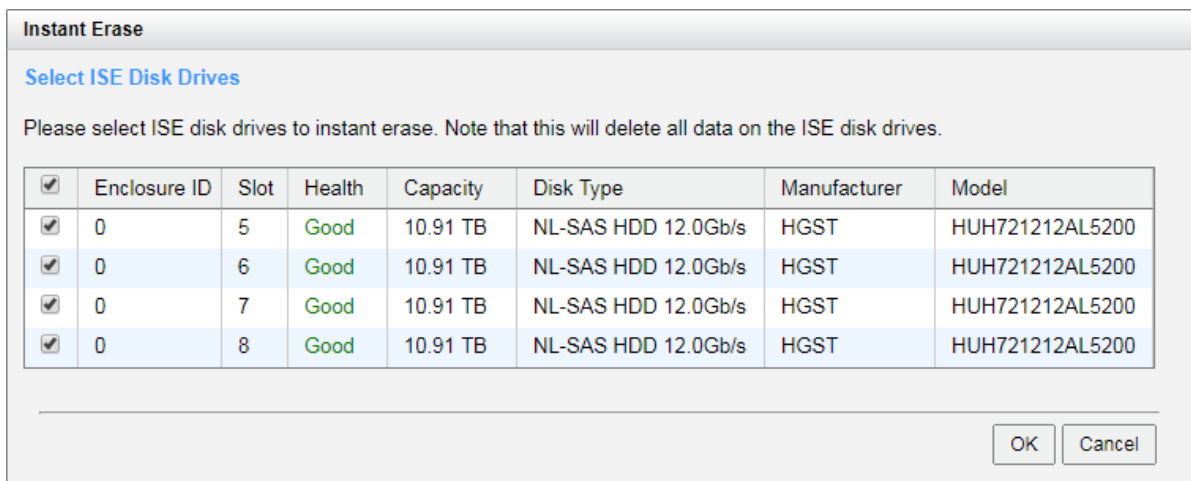

Figure 14-28 Instant Erase ISE drives

After proceeding, it will pop up a window to display the results.

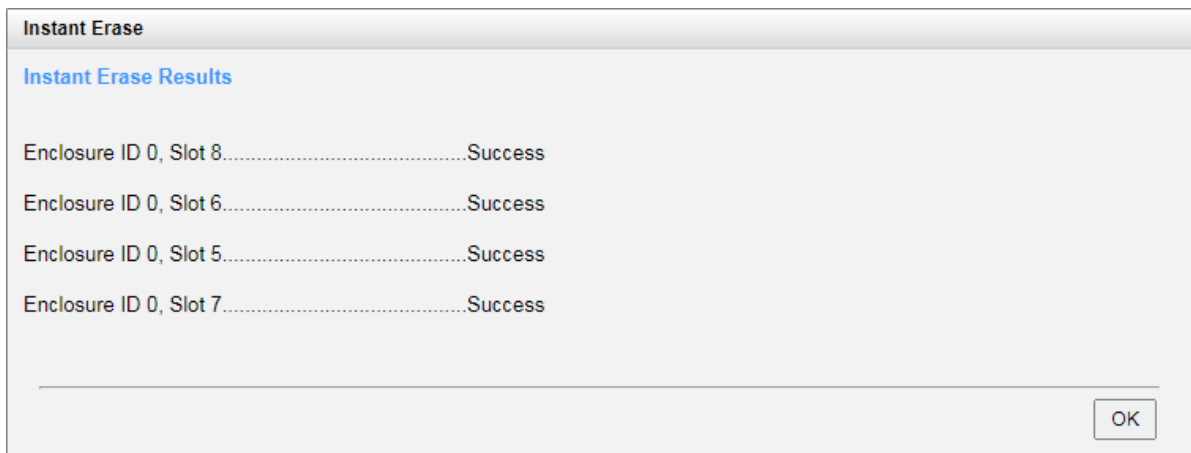

Figure 14-29 Instant Erase Results

**INFORMATION:**

The **Instant Erase** function can be operated when the usage status of ISE drives is free.

**CAUTION:**

Erasing the ISE drives will change the DEK and delete all data on the ISE drive. The data on ISE drive can never be restored, please exercise caution.

15. QoS (Quality of Service)

This chapter describes an overview and operations of volume QoS (Quality of Service).



INFORMATION:

The volume QoS is available in SANOS firmware 1.4.0.

15.1. Overview

QoS is a term used in the field of packet switched networks to refer to the probability that a network will satisfy a given business contract. In many cases, informally refers to the probability that a packet will pass between two points in the network. QoS has a control mechanism that provides different priorities for different users or different data streams, or ensures that the performance of the data stream reaches a certain level according to the requirements of the application.

QoS features exist in everything from network devices to hypervisors to storage. When multiple workloads share limited resources, QoS helps control how resources are shared and prevents the noisy applications from damaging the performance of all other applications on the same system.

In the early days of the Internet, it didn't realize the needs of QoS application, so the entire Internet operation was like a "best-effort" system. According to the sender and the receiver, many things happen during the packet transmissions from the start point to the end point, and the following problematic results are produced:

- **Lost packet:** When the packet arrives at a buffer full, it means that the transmission failed. The system will decide to discard part, or discard all packets according to the status of the network, and the application at the receiving end must request retransmission at this time, which may also cause a serious delay in the overall transmission.
- **Latency:** It may take a long time to transfer the packet to the destination because it can be delayed by a long queue. In short, the delay is very difficult to predict.
- **Incorrect transmission sequence:** When a group of related packets are routed through the Internet, different packets may choose different ways, which will result in different

delays for each packet. The order in which the last packet arrives at the destination is inconsistent with the order in which the packet is sent from the sender.

Although some specific forms of network data flow need to define service quality. QoS is developed to set priorities for data flows and set guaranteed limits of effectiveness, throughput, latency, etc. QoS guarantees are important for networks with limited bandwidth, especially for streaming multimedia applications such as VoIP (Voice over Internet Protocol) and IPTV (Internet Protocol Television), as these applications often require a fixed transmission rate and are sensitive to latency.

15.1.1. QoS in Storage System

The same situation exists in the storage system. QoS refers to service priority and resource reservation control mechanisms. QoS is the ability to provide different priorities for different volumes to guarantee a certain level of performance for a data stream.

Generally, a single service does not need QoS because it has the whole system resources. But for business-critical applications in multi-tenant, QoS is a key technology to deliver consistent primary storage performance and this predictable performance is also an important indicator.

15.1.2. Benefit of QoS

If different applications share the same storage platform, we can predict that the following issues may occur:

- Workloads with I/O conflicts, such as OLTP (Online Transaction Processing) and data warehousing.
- Tiering storage access restrictions, such as development and production applications.
- Peak demand processing for critical applications and maintenance activities.

Although raw storage performance is important, predictable and consistent performance delivery ensures that every application has the required resources to run without interruptions. QoS feature enables the storage system when serving these workloads.

- Prioritize the storage bandwidth and capacity resources.
- Consistently deliver predictable performance across multiple applications.
- Reduce unpredictable I/O patterns.
- Eliminate manual adjustments to adapt to changing workload demands.
- Allow application scale to grow without disrupting the system.

QoS feature makes it easier for users to assign I/O priorities. And it ensures a better service consolidation when serving these workloads.

15.1.3. QoS Use Cases

QoS is best for multi-tenant systems running different workloads with unpredictable requirements. Multi-tenant systems allow the flexibility to meet your business needs. Therefore, QoS is particularly effective at the following applications:

- Mission critical database applications: real-time transactional database (Exchange server, SQL server, RDBMS, DB2), OLTP (On-Line Transaction Processing).
- Consolidation a virtualization: virtualized data center, VMware, Hyper-V, Citrix.
- Private cloud computing and big data analytics.

15.2. Theory of Operation

Mention the evolution of the storage system, in order to meet different application performance requirements, the storage industry developed SSD cache and auto tiering technologies based on the traditional disk drives. These solutions apply complex algorithms and predictive methods to transfer data to the right media at the right time to improve performance. These approaches are costly and complex, and only apply to some form of certain data distribution, but may not meet the predictable performance requirements of mission-critical applications.

QoS is developed to resolve this difference. Each volume is configured with priority, target response time, or maximum IOPS and maximum throughput values that are strictly enforced within the system. The priority and target response time provides a guarantee for performance, as system resources allow. The maximum IOPS and maximum throughput values limit the allocation of performance and deliver consistent performance to workloads. The QoS feature ensures that multiple applications can run on a single storage platform without affecting each other.

After enabling QoS feature, we provide two options to configure. One is priority and target response time; the other is maximum IOPS and maximum throughput. Describe on the following.



Figure 15-1 Without and With QoS

15.2.1. Priority and Target Response Time

Set performance limits for each connected server based on priority. By prioritizing data access and dynamically managing any I/O conflicts, you can guarantee the high performance of high-priority applications while using capacity more efficiently.

To define the QoS volumes two parameters can be set:

1. **Priority:** Defines the service level of the volume that represents its priority. The volume priority can be set to high, medium, or low.
2. **Target response time:** Define the performance of each volume as the average of the read and write response times for that volume. The volume with high priority can be set the target response time. After setting, the performance of the volume is adjusted based on the defined target response time.

The QoS mechanism shares less I/O resources to the volumes with low priority. Volumes of higher priorities are granted greater processing I/O capabilities and achieve better response times as they approach the target.



INFORMATION:

The volume which sets to the high priority can be set the target response time.



TIP:

When the target response time is set properly and the system resources are sufficient, the latency of the volume will reach the target response time.

The system keeps checking the current value and the target response time. It is performed bandwidth adjustment if the measured volume response time does not match the expected target performance. After achieving the performance goal, QoS will continue to monitor the latency and adjust the resources as necessary. If the performance goal is not met, please view the volume configuration and QoS settings and change the tuning parameters properly.

15.2.2. Maximum IOPS and Maximum Throughput

Other than the priority option, the maximum IOPS and/or the maximum throughput can be configured to limit the volume processing I/O capabilities and bandwidth. It limits the maximum resources of the volume to not exceed, and reserved for other volumes.

To define the QoS volumes two options can be chosen:

1. **Unlimited:** Defines the service level of the volume that is no limit.
2. **Maximum IOPS and Maximum Throughput:** Define the performance of each volume as the maximum IOPS and/or throughput for that volume. The threshold can be set to two or one of. After setting, the performance of the volume is adjusted based on the defined values.

The QoS mechanism monitors the IOPS and throughput of the volume. It will block the I/O processing when the threshold is reached. Volumes with these settings are predictable and consistent performance delivery.



INFORMATION:

The maximum IOPS and maximum throughput settings can be set to two or one of.

15.3. Configure QoS Settings

This section will describe the operations of enabling QoS. Select the **QoS Settings** function tab in the **Volumes** function submenu to configure QoS the settings.

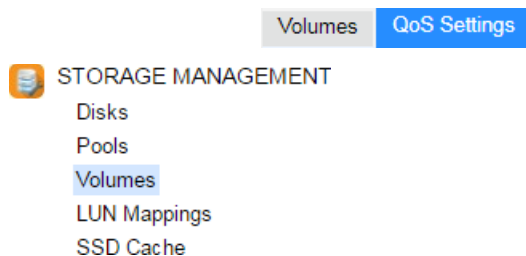

Figure 15-2 QoS Settings Function Tab

15.3.1. Operations on QoS Settings

The options are available in this tab.

Enable QoS Settings

Before using QoS, you have to enable the QoS settings.

1. Select the **QoS Settings** function tab in the **Volumes** function submenu.

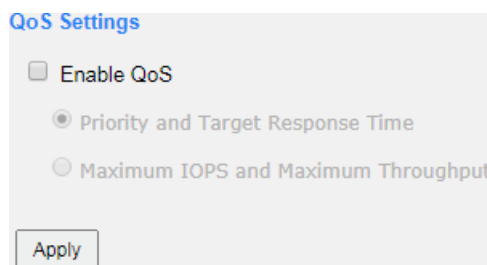

Figure 15-3 QoS Setting is Disabled

2. Check the **Enable QoS** checkbox to enable.
3. Select an option of **Priority and Target Response Time** or **Maximum IOPS and Maximum Throughput**.
4. Click the **Apply** button to enable.

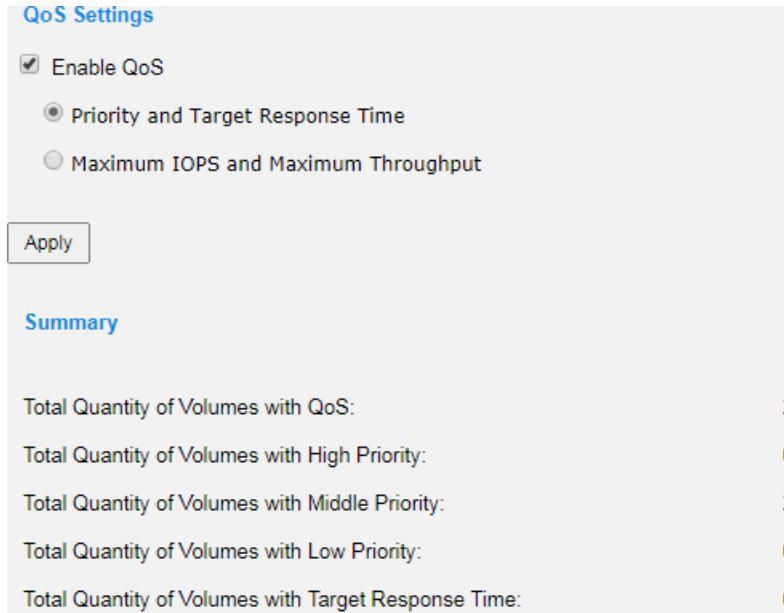

Figure 15-4 QoS Setting with Priority and Target Response

After the QoS setting is enabled, the relevant QoS summary is displayed in the page.

Change QoS Settings

The QoS settings can be changed dynamically.

1. Change the option of QoS setting.
2. Click the **Apply** button to change.

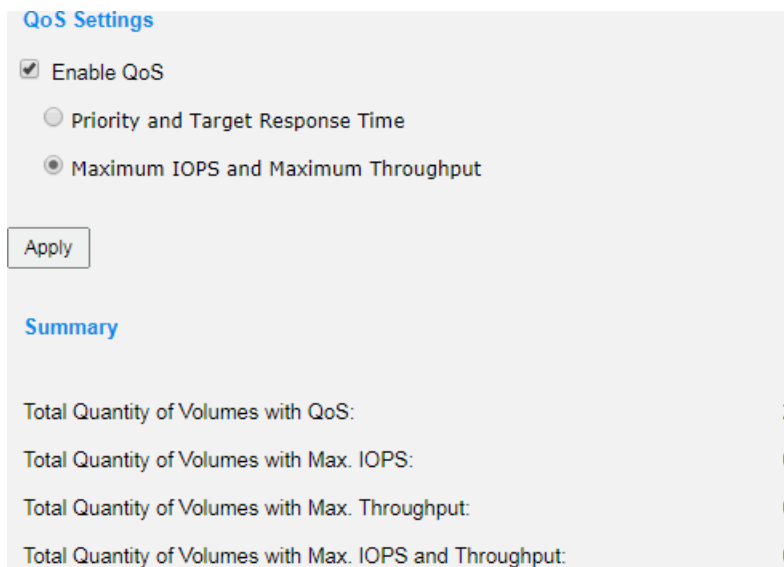

Figure 15-5 QoS Setting with Maximum IOPS and Maximum Throughput

The same, the relevant QoS summary is displayed in the page.

Disable QoS Settings

1. Uncheck the **Enable QoS** checkbox to disable.
2. Click the **Apply** button to disable.

15.4. Configure QoS Volumes

The **QoS Volumes** function tab in the **Volumes** function submenu is only visible when the QoS is enabled. Select the **QoS Volumes** function tab to display the status of QoS volumes, or configure the QoS volumes.

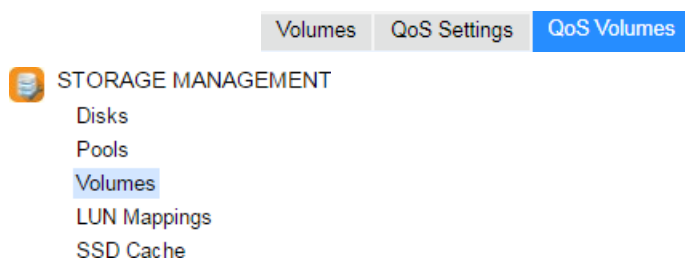

Figure 15-6 QoS Volumes Function Tab

15.4.1. List QoS Volumes

The QoS settings can be configured by clicking the functions button ▼ to the left side of the specific volume.

	Volume Name	Status	Health	Capacity	Priority	Current IOPS	Target Response Time	Current Response Time
▼	Vol-1	Online	Optimal	100.00 GB	Middle	0	N/A	0 msec.
▼	Vol-2	Online	Optimal	110.00 GB	Middle	0	N/A	0 msec.

Figure 15-7 List QoS Volumes with Priority and Target Response

	Volume Name	Status	Health	Capacity	Maximum IOPS	Current IOPS	Maximum Throughput	Current Throughput
▼	Vol-1	Online	Optimal	100.00 GB	Unlimited	0	Unlimited	0 KBps
▼	Vol-2	Online	Optimal	110.00 GB	Unlimited	0	Unlimited	0 KBps

Figure 15-8 List QoS Volumes with Maximum IOPS and Maximum Throughput

This table shows the column descriptions.

Table 15-1 QoS Volume Descriptions

Column Name	Description
Volume Name	The volume name.
Status	<p>The status of the volume:</p> <ul style="list-style-type: none"> • Online: The volume is online. • Offline: The volume is offline. • Erasing: The volume is being erased if the Erase Volume Data option is set. • Initiating: The volume is being initialized. • Rebuilding: The volume is being rebuilt. • Migrating: The volume is being migrated. • Rollback: The volume is being rolled back. • Parity Checking: The volume is being parity check. • Relocating: The volume is being relocated. • EE Rebuilding: The volume is being RAID EE rebuilt.
Health	<p>The health of the volume:</p> <ul style="list-style-type: none"> • Optimal: the volume is working well and there is no failed disk in the RG. • Failed: the pool disk of the volume has single or multiple failed disks than its RAID level can recover from data loss. • Degraded: At least one disk from the pool of the volume has failed or plugged out. • Non-optimal: the volume has experienced recoverable read errors. After passing parity check, the health will become Optimal.
Capacity	Total capacity of the volume.

Table 15-2 QoS Volume Descriptions with Priority and Target Response Time

Column Name	Description
Priority	<p>The priority of the volume:</p> <ul style="list-style-type: none"> • High

	<ul style="list-style-type: none"> • Middle • Low
Current IOPS	Current IOPS of the volume.
Target Response Time	Target response time setting, N/A is not configured.
Current Response Time	Current response time of the volume.

Table 15-3 QoS Volume Descriptions with Maximum IOPS and Maximum Throughput

Column Name	Description
Maximum IOPS	The maximum IOPS setting.
Current IOPS	Current IOPS of the volume.
Maximum Throughput	The maximum throughput setting.
Current Throughput	Current throughput of the volume.

15.4.2. Operations on QoS Volumes

The options are available in this tab.

Set Priority and Target Response Time

1. If the QoS setting is **Priority and Target Response Time**, select a volume, and then click ▼ -> **Set Priority** to configure.

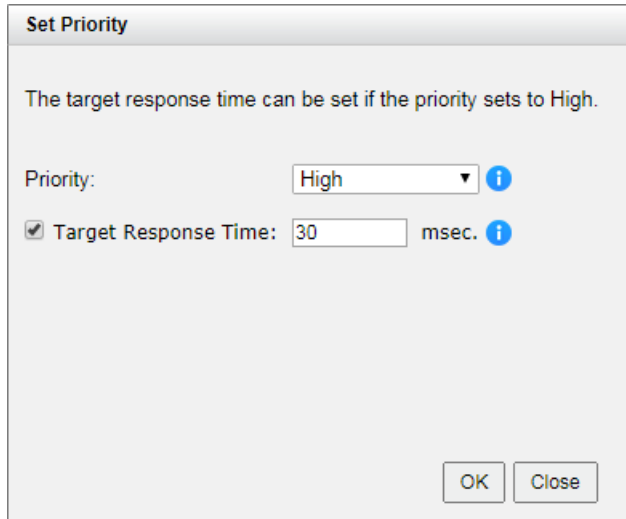

Figure 15-9 Set Priority

2. Select a **Priority** from the drop-down list. The default setting is **Middle**. The **Target Response Time** can be configured when the **Priority** is set to **High**.
3. If necessary, check the **Target Response Time** checkbox and enter a number. The number is between 1 and 10,000 milliseconds.
4. Click the **OK** button to set.

	Volume Name	Status	Health	Capacity	Priority	Current IOPS	Target Response Time	Current Response Time
▼	Vol-1	Online	Optimal	100.00 GB	High	0	30 msec.	0 msec.
▼	Vol-2	Online	Optimal	110.00 GB	Middle	0	N/A	0 msec.

Figure 15-10 Priority and Target Response Time are Set

Set Maximum IOPS and Maximum Throughput

1. If the QoS setting is **Maximum IOPS and Maximum Throughput**, select a volume, and then click ▼ -> **Set Maximum IOPS and Maximum Throughput** to configure.

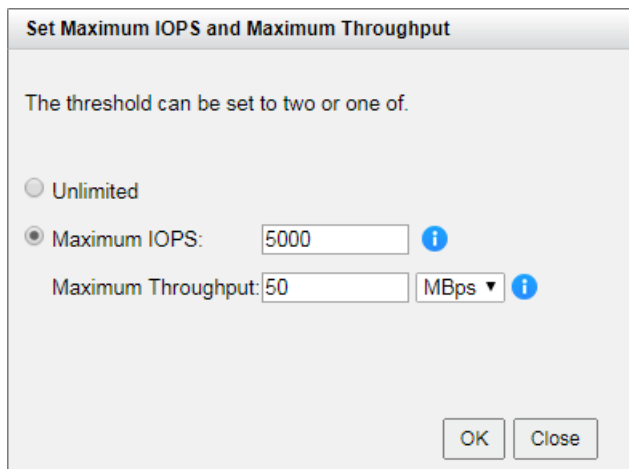

Figure 15-11 Set Maximum IOPS and Maximum Throughput

2. Select the **Unlimited** or **Maximum IOPS and Maximum Throughput** radio button.
3. If it is set to **Maximum IOPS and Maximum Throughput**, enter numbers for the maximum IOPS and/or the maximum throughput. The threshold can be set to two or one of. The maximum IOPS number is between 100 and 10,000,000. The maximum throughput number is between 50KBps and 100GBps.
4. Click the **OK** button to set.

	Volume Name	Status	Health	Capacity	Maximum IOPS	Current IOPS	Maximum Throughput	Current Throughput
▼	Vol-1	Online	Optimal	100.00 GB	5000	0	50 MBps	0 KBps
▼	Vol-2	Online	Optimal	110.00 GB	Unlimited	0	Unlimited	0 KBps

Figure 15-12 Maximum IOPS and Maximum Throughput are set

16. Troubleshooting

16.1. Fault Isolation Methodology

This section presents the basic methodology used to quickly locate faults within the storage system.

16.1.1. Basic Steps

The basic fault isolation steps are listed below:

- Gather fault information, including using system LEDs. Please refer to the chapter 5, Description of LEDs and Buttons in the [XCubeSAN Hardware Manual](#) for detail.
- Review event logs. Please refer to the chapter 13.1, [Log Center](#) section in the Monitoring chapter.
- Determine where the fault is occurring in the system. If the fault is occurring from hardware, please refer to the chapter 6, Quick Maintenance in the [XCubeSAN Hardware Manual](#) for detail.
- If required, isolate the fault to a disk drive, configuration, or system. Please refer to the chapter 15.1.3, [Diagnostic Steps](#) section.
- If all troubleshooting steps are inconclusive, please contact support for help.

16.1.2. Stopping I/O

When troubleshooting disk drive and connectivity faults, it's necessary to stop I/O to the affected volume data from all hosts and remote systems as a data protection precaution. As an additional data protection precaution, it is helpful to conduct regularly scheduled backups of your data.

16.1.3. Diagnostic Steps

The diagnostic steps are listed below:

- If disk drive errors in the event logs are occurring, we suggest replacing a healthy one. For more information, please refer to the chapter 15.2, [Rebuild](#) section.

- If the fault is occurring from volume configuration. For example, the pool or volume configuration is deleted by accident. Please refer to the chapter 15.3, [Volume Restoration](#) section for disaster recovery.
- If the fault is occurring from other hardware components of the system, the faulty component will need to be replaced.

16.2. Rebuild

If any single disk drive of the storage pool in protection RAID level (e.g., RAID 1, 3, 5, 6, 0+1, 10, 30, 50, and 60) fails or has been removed, then the status of pool will be changed to degraded mode. At the same time, the system will search the spare disk to execute volume rebuild the degraded pool into complete one.

There are three types of spare disk drive which can be set in function menu **Disks**:

- **Dedicated Spare**: Set a spare disk drive to a dedicated pool.
- **Local Spare**: Set a spare disk drive to the pools which located in the same enclosure. The enclosure is either in head unit or in one of expansion units.
- **Global Spare**: Set a spare disk drive to all pools which located whether in head unit and expansion unit.

The detection sequence is the dedicated spare disk as the rebuild disk first, then local spare disk and global spare disk.

The following examples are scenarios for a RAID 6 rebuild.

1. When there is no global spare disk or dedicated spare disk in the system, the pool will be in degraded mode and wait until there is one disk assigned as spare disk, or the failed disk is removed and replaced with new clean disk, and then the Auto-Rebuild starts.
2. When there are spare disks for the degraded array, system starts Auto-Rebuild immediately. In RAID 6, if there is another disk failure occurs during rebuilding, system will start the above Auto-Rebuild process as well. Auto-Rebuild feature only works at that the status of pool is **Online**. Thus, it will not conflict with the online roaming feature.
3. In degraded mode, the health of the pool is **Degraded**. When rebuilding, the status of pool and volume disk will display **Rebuilding**, the column **R%** in volume will display the ratio in percentage. After complete rebuilding, the status will become **Online**.



TIP:

The dedicated spare cannot be set if there is no pool or the pool is set to RAID level 0.

Sometimes, rebuild is called recover, they have the same meaning. This table describes the relationship between RAID levels and recovery.

Table 16-1 RAID Rebuild

Operation	Description
RAID 0	Disk striping. No protection for data. Pool fails if any disk drive fails or unplugs.
RAID 1	Disk mirroring over 2 disks. RAID 1 allows one disk drive fails or unplugging. Need one new disk drive to insert to the system and rebuild to be completed.
N-way mirror	Extension to RAID 1 level. It has N copies of the disk. N-way mirror allows N-1 disk drives failure or unplugging.
RAID 3	Striping with parity on the dedicated disk. RAID 3 allows one disk drive failure or unplugging.
RAID 5	Striping with interspersed parity over the member disks. RAID 5 allows one disk drive failure or unplugging.
RAID 6	2-dimensional parity protection over the member disks. RAID 6 allows two disk drives failure or unplugging. If it needs to rebuild two disk drives at the same time, it will rebuild the first one, then the other in sequence.
RAID 0+1	Mirroring of RAID 0 volumes. RAID 0+1 allows two disk drive failures or unplugging, but at the same array.
RAID 10	Striping over the member of RAID 1 volumes. RAID 10 allows two disk drive failure or unplugging, but in different arrays.
RAID 30	Striping over the member of RAID 3 volumes. RAID 30 allows two disk drive failure or unplugging, but in different arrays.
RAID 50	Striping over the member of RAID 5 volumes. RAID 50 allows two disk drive failures or unplugging, but in different arrays.
RAID 60	Striping over the member of RAID 6 volumes. RAID 60 allows four disk drive failures or unplugging, every two in different arrays.

16.3. Volume Restoration

The **Volume Restoration** can restore the volume configuration from the volume creation history. It is used for pool corruption and tries to recreate the volume. When trying to do data recovery, the same volume configurations as original must be set and all member disks must be installed by the same sequence as original. Otherwise, data recovery will fail. The volume restoration does not guarantee that the lost data can be restored. Please get help from an expert before executing this function.

The volume restoration can restore your previous volume configurations when a pool corruption or a mis-delete occurs. Before restoration, please make sure that all the member disks are installed and lost data will be recovered. Please contact for support before using this function.

Enclosure ID: 0 (Head Unit: X55216) ▼

<< first < prev 1 2 3 4 5 6 7 8 9 10 next > last >>

	Pool Name	RAID	Volume Name	Volume Capacity	Disks Used	Disk Slot	Time	Event Logs
▼	Pool-1	RAID 5	Source-Vol-1	10 GB	4	0:1, 0:2, 0:3, 0:4	2017/07/12 13:48:50 CST	The snapshot space has initialized.
▼	Pool-1	RAID 5	Target-Vol-2	11 GB	4	0:1, 0:2, 0:3, 0:4	2017/07/12 13:46:20 CST	The volume is created.
▼	Pool-1	RAID 5	Target-Vol-2	11 GB	4	0:1, 0:2, 0:3, 0:4	2017/07/12 13:44:06 CST	The volume is created.
▼	Pool-1	RAID 5	Source-Vol-1	10 GB	4	0:1, 0:2, 0:3, 0:4	2017/07/12 13:43:13 CST	The volume is created.
▼	Pool-1	RAID 5	Vol-1	100 GB	3	0:9, 0:10, 0:11	2017/07/12 13:23:53 CST	The snapshot space has initialized.
▼	Pool-1	RAID 5	Target-Vol-2	110 GB	3	0:9, 0:10, 0:11	2017/07/12 10:11:59 CST	The volume is created.
▼	Pool-1	RAID 5	Vol-2	100 GB	5	0:9, 0:10, 0:11, 0:1, 0:2	2017/07/11 17:55:13 CST	The volume is created.
▼	Pool-1	RAID 5	Vol-1	100 GB	5	0:9, 0:10, 0:11, 0:1, 0:2	2017/07/11 17:55:02 CST	The volume is created.
▼	Pool-1	RAID 5	Vol-1	150 GB	3	0:9, 0:10, 0:11	2017/07/11 17:12:07 CST	The volume is created.
▼	Pool-1	RAID 5	Vol-1	150 GB	5	0:9, 0:10, 0:11, 0:1, 0:2	2017/07/11 11:01:53 CST	The volume is expanded.
▼	Pool-1	RAID 5	Target-Vol-2	110 GB	5	0:9, 0:10, 0:11, 0:1, 0:2	2017/07/11 10:58:28 CST	The volume is created.
▼	Pool-1	RAID 5	Vol-1	100 GB	5	0:9, 0:10, 0:11, 0:1, 0:2	2017/07/11 10:28:02 CST	The volume is created.

<< first < prev 1 2 3 4 5 6 7 8 9 10 next > last >>

Figure 16-1 Volume Restoration

This table shows the column descriptions.

Table 16-2 Volume Restoration Column Descriptions

Column Name	Description
Pool Name	The original pool name.
RAID	The original RAID level.
Volume	The original volume name.
Volume Capacity	The original capacity of the volume.
Disks Used	The original quantity of physical disk in the pool.
Disk Slot	The original physical disk locations.
Time	The last action time of the volume.
Event Logs	The last event of the volume.



TIP:

When attempting data recovery, the same volume configurations as the original must be set and all member disks must be installed by the same sequence as original. Otherwise, data recovery will fail.



CAUTION:

Performing data recovery does not guarantee that the lost data can be restored 100%. It depends on the real operation and the degree of physical damages on disks. Users assume all risk when attempting data recovery procedures.

16.3.1. Configure Volume Restoration

The options are available in this tab:

Restore the Volume

Click ▼ -> **Restore** to restore the deleted volume in the pool. And then click the **OK** button to proceed.

17. Support and Other Resources

17.1. Getting Technical Support

After installing your device, locate the serial number on the sticker located on the side of the chassis or from the SANOS UI -> **SYSTEM SETTING** -> **Maintenance** -> **System Information** and use it to register your product at https://www.qsan.com/business_partnership. We recommend registering your product in QSAN partner website for firmware updates, document download, and latest news in eDM. To contact QSAN Support, please use the following information.

- Via the Web: https://www.qsan.com/technical_support
- Via Telephone: +886-2-77206355
(Service hours: 09:30 - 18:00, Monday - Friday, UTC+8)
- Via Skype Chat, Skype ID: qsan.support
(Service hours: 09:30 - 02:00, Monday - Friday, UTC+8, Summer time: 09:30 - 01:00)
- Via Email: support@qsan.com

Information to Collect

- Product name, model or version, and serial number
- Operating system name and version
- Firmware version
- Error messages or capture screenshots
- Product-specific reports and logs
- Add-on products or components installed
- Third-party products or components installed

Information for Technical Support

The following system information is necessary for technical support. Please refer to following for what and where to get the information of QSAN product.

If the technical support requests you to download the Service Package, please navigate in the SANOS UI -> **SYSTEM SETTING** -> **Maintenance** -> **System Information**, and then click the **Download Service Package** button to download. Then the system will automatically generate a zip file the default download location of your web browser.

System

Item	Information
System Name	XS5216-D40000
Model Name	XS5216
System Serial Number	QW3160160I0021001
System Controller Status	Dual Controller, Active-Active
Master Controller	Controller 1

Controller 1

Item	Information
Controller Serial Number	50013780080A0440
CPU	Intel(R) Xeon(R) Processor D-1500 4 Cores
Memory	8 GB
Host Card Slot 1	Empty
Host Card Slot 2	Empty
Firmware Version	1.2.0
SAS IOC Firmware Version	07.00.01.00
SAS Expander Firmware Version	1000

Controller 2

Item	Information
Controller Serial Number	50013780080A0440
CPU	Intel(R) Xeon(R) Processor D-1500 4 Cores
Memory	8 GB
Host Card Slot 1	Empty
Host Card Slot 2	Empty
Firmware Version	1.2.0
SAS IOC Firmware Version	07.00.01.00
SAS Expander Firmware Version	1000

Backplane

Information	Item
001378D40000	Backplane Serial Number
QW316	Backplane ID
1.2.0	MCU Version

Licenses

Information	Item
Enabled	SSD Cache
Enabled	Auto Tiering

Figure 17-1 Download Service Package in the SANOS UI

17.2. Online Customer Support

For better customer support, QSAN product includes the console cable for online support. Please follow the procedures below to setup the online help environment for QSAN support team.

The following procedure will help you to setup the serial console via the console cable that is enclosed in the shipping carton. The following image is the appearance of the console cable.



Figure 17-2 Appearance of a Console Cable

Procedures to Setup the Serial Console

1. Setup the serial cable between the controller and one server/host like in the below image.

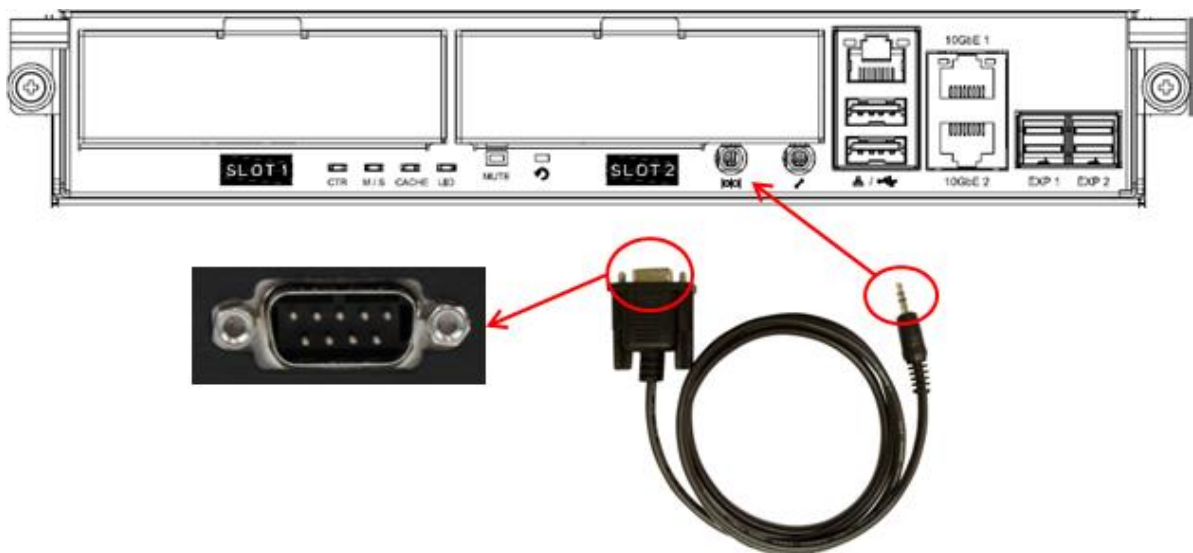

Figure 17-3 Connect the Console Cable

2. You must use terminal software such as HyperTerminal or Putty to open the console after the connection is made.



INFORMATION:

For more information about terminal software, please refer to

HyperTerminal: <http://www.hilgraeve.com/hyperterminal/>

PuTTY: <http://www.putty.org/>

3. Here we first demonstrate HyperTerminal. The console settings are on the following.
Baud rate: 115200, 8 data bit, no parity, 1 stop bit, and no flow control
Terminal type: vt100

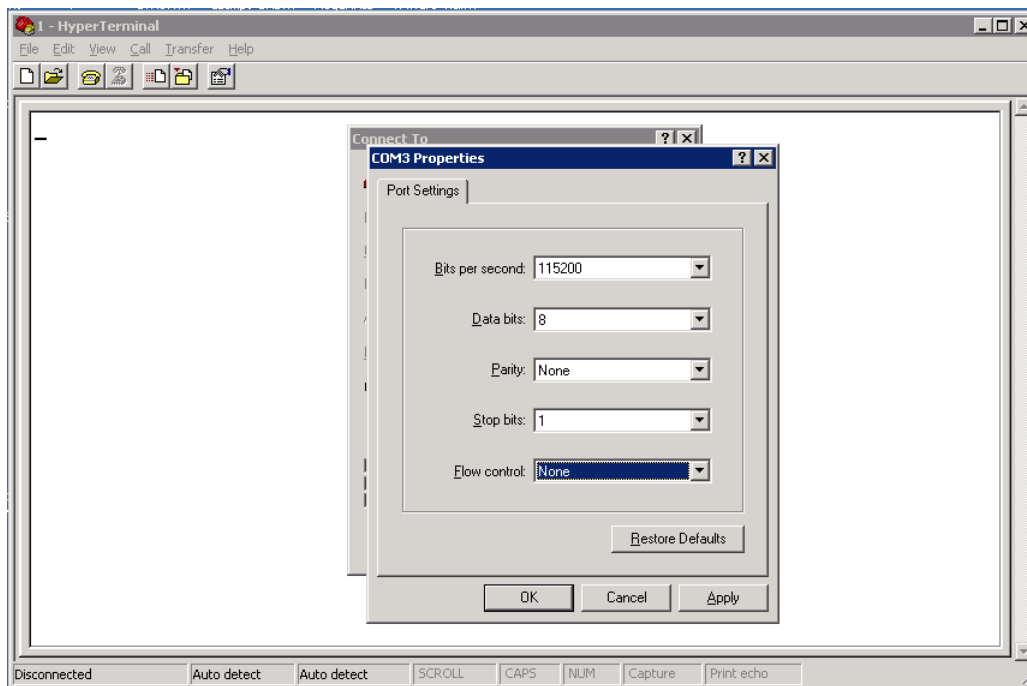

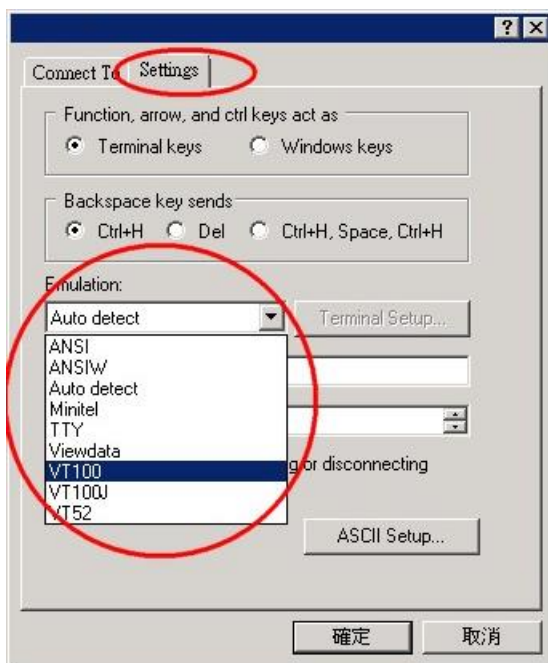
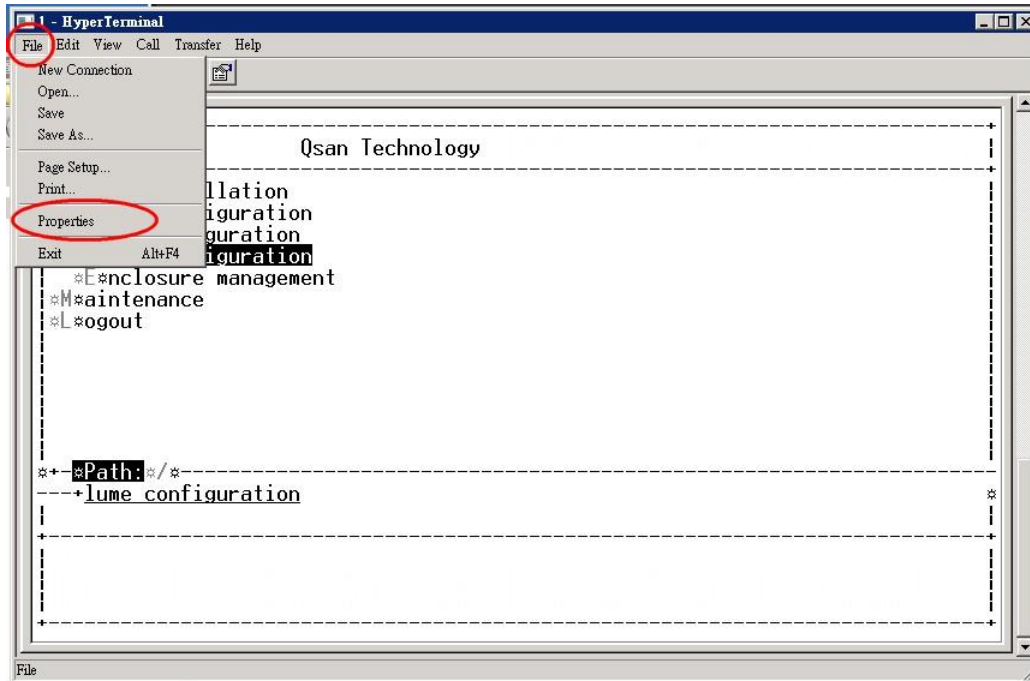
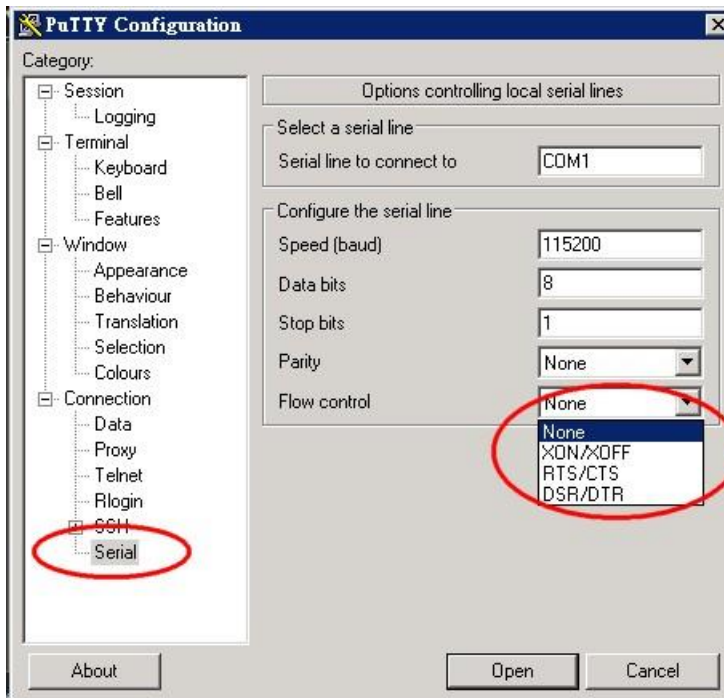
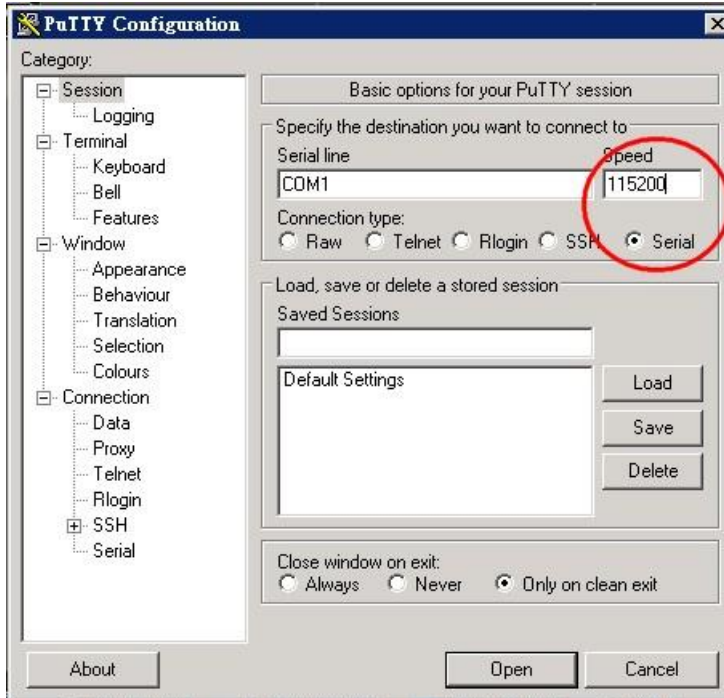

Figure 17-4 The Procedures of Setup Serial Console by HyperTerminal

4. If you are using PuTTY instead, please refer to below



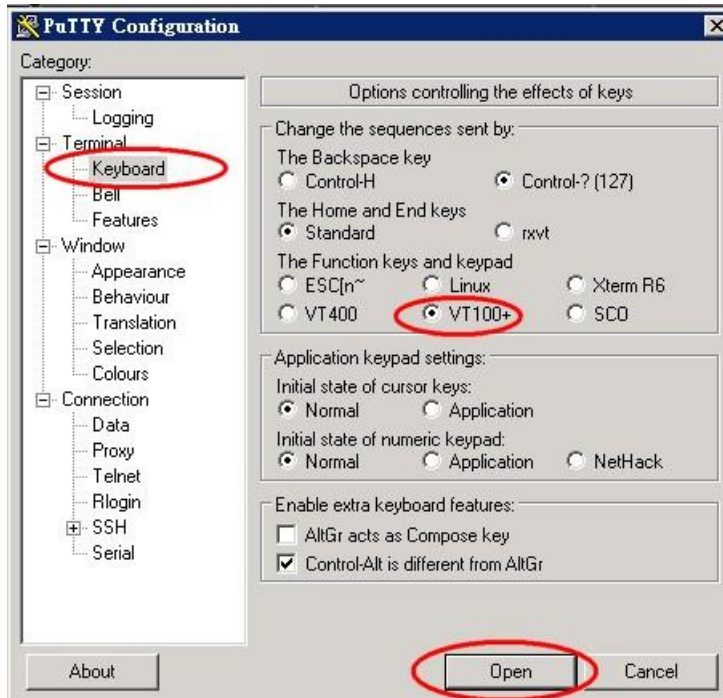

Figure 17-5 The Procedures of Setup Serial Console by PuTTY

5. Users should be able to login the controller system via console cable by following the procedures above.

Setup the Connection for Online Support

Following is the procedure to setup the connection for online support via TeamViewer:

1. Please download the TeamViewer from following hyper link:
<https://www.teamviewer.com/en/download/>
2. Install TeamViewer.
3. Please provide the ID/password showed on the application to QSAN support team member to join the online support session.

17.3. Accessing Product Updates

To download product updates, please visit QSAN website:

https://www.qsan.com/download_center

17.4. Documentation Feedback

QSAN is committed to providing documentation that meets and exceeds your expectations. To help us improve the documentation, email any errors, suggestions, or comments to docsfeedback@qsan.com.

When submitting your feedback, include the document title, part number, revision, and publication date located on the front cover of the document.

Appendix

Glossary and Acronym List

Common Terminology

Item	Description
RAID	Redundant Array of Independent Disks. There are different RAID levels with different degree of data protection, data availability, and performance to host environment.
Disk	The Physical Disk belongs to the member disk of one specific RAID group.
Pool	A collection of removable media. One pool consists of a set of volumes and owns one RAID level attribute.
Volume	Each pool could be divided into several volumes. The volumes from one pool have the same RAID level, but may have different volume capacity.
LUN	Logical Unit Number. A logical unit number (LUN) is a unique identifier which enables it to differentiate among separate devices (each one is a logical unit).
WebUI	Web User Interface.
WT	Write-Through cache-write policy. A cache technique in which the completion of a write request is not signaled until data is safely stored in non-volatile media. Each data is synchronized in both data cache and accessed physical disks.
WB	Write-Back cache-write policy. A cache technique in which the completion of a write request is signaled as soon as the data is in cache and actual writing to non-volatile media occurs at a later time. It speeds up system write performance but needs to bear the risk where data may be inconsistent between data cache and the physical disks in one short time interval.
RO	Set the volume to be Read-Only.
DS	Dedicated Spare disks. The spare disks are only used by one specific

	RAID group. Others could not use these dedicated spare disks for any rebuilding purpose.
LS	Local Spare disks. The spare disks are only used by the RAID groups of the local enclosure. Other enclosure could not use these local spare disks for any rebuilding purpose.
GS	Global Spare disks. It is shared for rebuilding purpose. If some RAID groups need to use the global spare disks for rebuilding, they could get the spare disks out from the common spare disks pool for such requirement.
DG	DeGraded mode. Not all of the array's member disks are functioning, but the array is able to respond to application read and write requests to its virtual disks.
SCSI	Small Computer System Interface
SAS	Serial Attached SCSI
S.M.A.R.T.	Self-Monitoring Analysis and Reporting Technology
WWN	World Wide Name
HBA	Host Bus Adapter
SES	SCSI Enclosure Services
NIC	Network Interface Card
BBM	Battery Backup Module
SCM	Super Capacitor Module

FC / iSCSI / SAS Terminology

Item	Description
FC	Fibre Channel
FC-P2P	Point-to-Point
FC-AL	Arbitrated Loop
FC-SW	Switched Fabric
iSCSI	Internet Small Computer Systems Interface
LACP	Link Aggregation Control Protocol
MPIO	Multipath Input/Output
MC/S	Multiple Connections per Session
MTU	Maximum Transmission Unit
CHAP	Challenge Handshake Authentication Protocol. An optional security

	mechanism to control access to an iSCSI storage system over the iSCSI data ports.
iSNS	Internet Storage Name Service
SAS	Serial Attached SCSI

Dual Controller Terminology

Item	Description
SBB	Storage Bridge Bay. The objective of the Storage Bridge Bay Working Group (SBB) is to create a specification that defines mechanical, electrical and low-level enclosure management requirements for an enclosure controller slot that will support a variety of storage controllers from a variety of independent hardware vendors (“IHVs”) and system vendors.
6G MUX	Bridge board is for SATA II disk to support dual controller mode.



End-User License Agreement (EULA)

Please read this document carefully before you use our product or open the package containing our product.

YOU AGREE TO ACCEPT TERMS OF THIS EULA BY USING OUR PRODUCT, OPENING THE PACKAGE CONTAINING OUR PRODUCT OR INSTALLING THE SOFTWARE INTO OUR PRODUCT. IF YOU DO NOT AGREE TO TERMS OF THIS EULA, YOU MAY RETURN THE PRODUCT TO THE RESELLER WHERE YOU PURCHASED IT FOR A REFUND IN ACCORDANCE WITH THE RESELLER'S APPLICABLE RETURN POLICY.

General

QSAN Technology, Inc. ("QSAN") is willing to grant you ("User") a license of software, firmware and/or other product sold, manufactured or offered by QSAN ("the Product") pursuant to this EULA.

License Grant

QSAN grants to User a personal, non-exclusive, non-transferable, non-distributable, non-assignable, non-sub-licensable license to install and use the Product pursuant to the terms of this EULA. Any right beyond this EULA will not be granted.

Intellectual Property Right

Intellectual property rights relative to the Product are the property of QSAN or its licensor(s). User will not acquire any intellectual property by this EULA.

License Limitations

User may not, and may not authorize or permit any third party to: (a) use the Product for any purpose other than in connection with the Product or in a manner inconsistent with the design or documentations of the Product; (b) license, distribute, lease, rent, lend, transfer, assign or otherwise dispose of the Product or use the Product in any commercial hosted or service bureau environment; (c) reverse engineer, decompile, disassemble or attempt to discover the source code for or any trade secrets related to the Product, except and only to the extent that such activity is expressly permitted by applicable law notwithstanding this limitation; (d) adapt, modify, alter, translate or create any derivative works of the Licensed Software; (e) remove, alter or obscure any copyright notice or other proprietary rights notice on the Product; or (f) circumvent or attempt to circumvent any methods employed by QSAN to control access to the components, features or functions of the Product.

Disclaimer

QSAN DISCLAIMS ALL WARRANTIES OF PRODUCT, INCLUDING BUT NOT LIMITED TO ANY MERCHANTABILITY, FITNESS FOR A PARTICULAR PURPOSE, WORKMANLIKE EFFORT, TITLE, AND NON-INFRINGEMENT. ALL PRODUCTS ARE PROVIDED "AS IS" WITHOUT WARRANTY OF ANY KIND. QSAN MAKES NO WARRANTY THAT THE PRODUCT WILL BE FREE OF BUGS, ERRORS, VIRUSES OR OTHER DEFECTS.

IN NO EVENT WILL QSAN BE LIABLE FOR THE COST OF COVER OR FOR ANY DIRECT, INDIRECT, SPECIAL, PUNITIVE, INCIDENTAL, CONSEQUENTIAL OR SIMILAR DAMAGES OR LIABILITIES WHATSOEVER (INCLUDING, BUT NOT LIMITED TO LOSS OF DATA, INFORMATION, REVENUE, PROFIT OR BUSINESS) ARISING OUT OF OR RELATING TO THE USE OR INABILITY TO USE THE PRODUCT OR OTHERWISE UNDER OR IN CONNECTION WITH THIS EULA OR THE PRODUCT, WHETHER BASED ON CONTRACT, TORT (INCLUDING NEGLIGENCE), STRICT LIABILITY OR OTHER THEORY EVEN IF QSAN HAS BEEN ADVISED OF THE POSSIBILITY OF SUCH DAMAGES.

Limitation of Liability

IN ANY CASE, QSAN'S LIABILITY ARISING OUT OF OR IN CONNECTION WITH THIS EULA OR THE PRODUCT WILL BE LIMITED TO THE TOTAL AMOUNT ACTUALLY AND ORIGINALLY PAID BY CUSTOMER FOR THE PRODUCT. The foregoing Disclaimer and Limitation of Liability will apply to the maximum extent permitted by applicable law. Some jurisdictions do not allow the exclusion or limitation of incidental or consequential damages, so the exclusions and limitations set forth above may not apply.

Termination

If User breaches any of its obligations under this EULA, QSAN may terminate this EULA and take remedies available to QSAN immediately.

Miscellaneous

- QSAN reserves the right to modify this EULA.
- QSAN reserves the right to renew the software or firmware anytime.
- QSAN may assign its rights and obligations under this EULA to any third party without condition.
- This EULA will be binding upon and will inure to User's successors and permitted assigns.

- This EULA shall be governed by and constructed according to the laws of R.O.C. Any disputes arising from or in connection with this EULA, User agree to submit to the jurisdiction of Taiwan Shilin district court as first instance trial.